

# *United States Air Force*

## *Early Systems Engineering Guidebook*



Assistant Secretary of the Air Force for Acquisition  
(SAF/AQ)

Version 1

## NOTICE AND SIGNATURE PAGE

Copies of this Guidebook may be obtained via the AF Portal at the SAF/AQR Organizational Home Page:

<https://www.my.af.mil/gcss-sf/USAF/ep/globalTab.do?channelPageId=-192441&command=org>

THIS GUIDEBOOK IS APPROVED FOR PUBLICATION

  
TERRY J. JAGGERS, SES  
Deputy Assistant Secretary  
(Science, Technology, and Engineering)

0902 01 2008

\_\_\_\_\_  
Date

This publication is intended for use by program managers and systems engineers.  
This document is in the public domain and may be copied.

Questions or corrections should be referred to SAF/AQRE, 703.588.7845 (DSN 425.7845)

## EXECUTIVE SUMMARY

This guide is intended to provide system stakeholders with an understanding of Systems Engineering (SE) processes and products used during the early (pre-Milestone [MS] A) stages of the acquisition process. It describes how each SE process and product contributes to the eventual delivery of a system with the desired capabilities, whether a new program start or a modification or upgrade to a legacy system.

Capabilities-Based Assessment (CBA) is the analytic basis of the Joint Capabilities Integration and Development System (JCIDS) process, detailed in the J8 JCIDS Manual (Feb 2009). JCIDS is responsible for identifying, developing, and validating all joint defense-related capability needs to be satisfied by future systems. CBA/JCIDS begins an incremental refinement process that culminates in the start of the DoD 5000.02 (Dec 2008) acquisition life cycle at a Materiel Development Decision (MDD); this is followed by the entry of two or more concepts into an Analysis of Alternatives (AoA), and the eventual selection of a Preferred System Concept (PSC). Subsequent pre-acquisition activities develop the detailed technical requirements for the system based on the PSC, and begin to identify the activities, data, and personnel needed to establish a technology development (TD) effort after the MS A decision.

SE in concept development must parallel user discussions of candidate materiel approaches, and must also involve all stakeholders. An expanded knowledge base before MDD provides:

- More robust and consistently defined concepts for consideration in AoAs
- Better PSC maturation thru MS A
- Better requirements definition and risk assessments in support of MS A and B decisions, and for technical efforts during the TD phase

This initial release of the Early Systems Engineering Guide focuses on SE efforts prior to the AoA, and identifies key activities and products of post-AoA efforts. Subsequent updates will flesh out this pre-MS A content, and will address key elements of planning for the more extensive SE activities in the TD phase between MS A and B.

# TABLE OF CONTENTS

<b>EXECUTIVE SUMMARY .....</b>	<b>i</b>
<b>1. Introduction.....</b>	<b>1</b>
1.1 Purpose .....	3
1.2 Background .....	3
1.3 Organizational Roles .....	5
1.4 Continuous Capability Planning Overview .....	7
1.5 System-of-Systems (SoS) Perspective .....	8
1.5.1 SE for SoS .....	8
1.5.2 SoS Architectures .....	8
1.5.3 Interoperability and Design Considerations .....	9
1.5.4 SoS Modeling and Simulation.....	9
<b>2. Capability-Based Assessment (CBA) .....</b>	<b>10</b>
<b>3. Concept Exploration and Refinement (CER) (CBA to AoA) .....</b>	<b>11</b>
3.1 Overview .....	11
3.2 Methodology .....	11
3.2.1 Control Function.....	11
3.2.2 Inputs .....	11
3.2.3 Concept Engineering Team .....	12
3.3 Tradespace Characterization Phase .....	12
3.3.1 Authorization to Proceed Review.....	13
3.3.2 Capability Decomposition and Analysis .....	13
3.3.3 Requirements/Characteristics Exploration and Synthesis .....	14
3.3.4 Trade Space and Exploratory Analysis .....	14
3.3.5 Candidate Solution Set Selection .....	15
3.4 Candidate Solution Sets Characterization Phase.....	15
3.4.1 Architecture Characterization.....	16
3.4.2 Initial Concept Review .....	16
3.4.3 System Characterization.....	17
3.4.4 Key Subsystem Characterization.....	17
3.4.5 Concept Characterization Review .....	17
3.5 Programmatic Analysis Phase .....	18
3.5.1 Cost/Effectiveness/Risk Analysis; Acquisition Timeline Verification .....	18
3.5.2 Requirements Verification .....	18
3.5.3 Final Concepts Review.....	18
3.5.4 Acquisition Timeline Verification/Capability Assessment.....	19
3.5.5 Release Approval Milestone .....	19
3.5.6 Outputs .....	19
3.6 Documentation .....	19
3.6.1 Concept Characterization and Technical Description (CCTD) Document .....	20
3.6.2 Architecture Products .....	20
3.6.3 Other Products .....	21
3.7 Repository .....	21

<b>4. Post-AoA Phase (AoA to MS A)</b> .....	<b>22</b>
4.1 Risk.....	22
4.2 Other Maturation Activities.....	23
4.2.1 Functional Analysis and Allocation .....	24
4.2.2 Defining Interfaces .....	24
4.2.3 Trade Studies .....	24
4.2.4 Models .....	24
4.2.5 Metrics .....	24
4.2.6 Documentation .....	24
<b>ABBREVIATIONS AND ACRONYMS</b> .....	<b>25</b>
<b>ANNEX A -- Concept Characterization &amp; Technical Description (CCTD) Format</b> .....	<b>27</b>
<b>ANNEX B -- Materiel Development Decision (MDD)</b> .....	<b>28</b>
<b>REFERENCES</b> .....	<b>29</b>

#### **FIGURES**

<b>Figure 1.1 DoDI 5000.2 (Dec 2008) acquisition life cycle</b>	<b>3</b>
<b>Figure 1.2 Early Systems Engineering</b>	<b>4</b>
<b>Figure 1.3 Relative levels of effort during CER</b>	<b>5</b>
<b>Figure 2.1 JCIDS Capability-Based Assessment (CBA)</b>	<b>10</b>
<b>Figure 3.1 Tradespace Characterization Phase of CBR</b>	<b>13</b>
<b>Figure 3.2 Candidate Solution Sets Characterization Phase of CBR</b>	<b>16</b>
<b>Figure 3.3 Programmatic Analysis Phase of CBR</b>	<b>19</b>

#### **TABLES**

<b>Table 3.1 DoDAF views incorporated into the CER process</b>	<b>19</b>
--	-----------

## 1. Introduction

Most military assets, from high-profile major weapon systems to behind-the-scenes business and information systems, now remain in inventory for a life cycle far exceeding what acquirers and designers anticipated. Modernization and acquisition dollars are deferred to accommodate more operations and maintenance expenses incurred by continued use of these aging systems and equipment; cost and schedule issues on many programs, and lower-than-expected performance capabilities of delivered systems, have further aggravated the situation.

Strategic investment decisions must rest on solid data about the potential applications of technologies, as well as the technologies themselves. Smart and well-informed decisions on which technologies to pursue as concepts, and then on which concepts to follow through as a small number of acquisition programs, should reflect a realistic and integrated assessment of all critical factors. The knowledge base used to inform these decisions should be developed using systems engineering (SE) fundamentals, just as these same fundamentals will be applied later in the life cycle to transform requirements into design solutions. Consistent process application, sound technical planning and analyses, and rigorous and well-documented trade studies will yield essential information for decision-makers at all stages.

The 2006 Defense Acquisition Performance Assessment (DAPA) Project Report Survey Results showed that requirements instability was the most mentioned problem area, followed by funding instability and technology maturity. A significant majority (96 percent) of respondents cited at least one of these three areas as critical to maintaining program cost, schedule, and performance. Another strong and recurring theme among those surveyed was the essential need for all stakeholders – in particular, the requirements, test, and acquisition communities – to agree on a baseline requirements set and the verification plan prior to contract award. The report also stresses that the greatest trade space, and thus the largest risk reduction opportunity, exists between Milestones (MS) A and B. Although DoD places most program focus on MS B, an integrated balance of technology maturity, system capability, cost, and program risk is not being agreed to prior to program initiation. Thus, programs frequently come into existence facing excessive cost, schedule, and performance risks.

Requirements must be expressed with completeness and accuracy to minimize costly and time-consuming changes during the development process. One way to obtain these qualities is to analyze the needed capability and associated constraints in the context of the concept of operations and the characteristics of the operational environment.

Examination of an initial capability needs statement allows developers to identify a relevant operational context, and to craft appropriate Measures of Effectiveness (MOE) for assessing the military utility of each concept as it comes forward. They also begin to populate the technical knowledge base with documented ground rules, assumptions, and constraints (technical, operational, and programmatic) as the operational and functional allocations progress to a point where concept-specific Measures of Performance (MOP) can be identified.

In laboratories, academia, and industry thousands of technologies are being developed and matured. Hundreds may have some expected military utility; tens may be actually able to address well-articulated needs or capability gaps. A robust and comprehensive methodology to winnow the “blue-sky” ideas down to possibilities, and then to prospective concepts, is essential.

Architectures and concepts are created or invented based on an understanding of the state of the art in both design and technology, and the awareness of the state of the possible in technology, followed by assessments of responsiveness to operational requirements and constraints. They can range from upgrades or evolutions of existing assets to completely new systems and equipment, and generally include elements of each. Attributes must be assessed and balanced with respect to parameters such as effectiveness, cost, schedule, risk, and evolutionary potential; this is a key element of the Analysis of Alternatives (AoA) that selects a Preferred System Concept (PSC).

Balance between effectiveness, cost, and other factors can usefully inform the work of operators and users, leading to a statement of capability needs that can be affordably and feasibly satisfied. It is important in selection of concept or design parameters in the trade space among technical requirements corresponding to the threshold needed capability and the objectives. Balance also impacts the selection of design margins to ensure that the needed capability is achieved in the final delivered system. While this clearly occurs during detail design activities after formal program initiation, such margins also apply to the difference between the technical requirements and the predictions of effectiveness for a given design concept or design approach. Other important margins that must also be balanced apply to the difference between predictions of worst-case environments and the technical constraints imposed on and subsequently met by the design. Predicted or estimated costs should be compared with affordability goals or constraints.

Analysis may show that some aspect of a needed capability is not achievable at low risk, that the cost may be unaffordable, or that the schedule (to, say, mature a needed technology) is unattainable. To guide each iteration and tradeoff aimed at achieving initial baselines, and then to determine potential impacts and benefits of changes that are subsequently proposed, it is essential to maintain a record of the basis for each decision made in developing and maintaining each baseline. This decision database typically contains:

- The SE program foundation
- Each of the system baselines and the functional architecture (or other logical representation)
- Iteration/trade study results including assessments of cost, schedule, risk, and evolutionary growth potential and analytic techniques applied
- The chronology of decisions and implementing actions
- History of changes including approval authority and rationale

SE in concept development must parallel user discussions of candidate materiel approaches, and must also involve all stakeholders. An expanded knowledge base before the Materiel Development Decision (MDD) provides:

- More robust and consistently defined concepts for consideration in AoAs
- Better PSC maturation through MS A
- Better requirements definition and risk assessments in support of MS A and B documentation and decisions, and for technical efforts such as technology maturation, prototyping, etc. that occur during the Technology Development phase

## 1.1 Purpose

This guide is intended to be used by the Air Force and its industry partners to improve early systems engineering (SE) efforts in the development of concepts to address capability gaps or exploit new technologies.

## 1.2 Background

Air Force Instruction (AFI) 63-1201, *Life Cycle Systems Engineering*, governs the use of SE across the Air Force. Para. 1.1.1 of the AFI summarizes the focus: “Air Force SE involves comprehensive planning, management, and execution of rigorous technical efforts to develop, field, and sustain robust products and systems. Application of SE fundamentals must begin with concept inception, and must cover all efforts across all life cycle phases, to include sustainment and disposal, for all Air Force products and systems.”

SE collects, coordinates, and ensures traceability of all stakeholder needs into a set of system requirements through a balanced process that takes into account effectiveness, performance, cost, schedule, and risk. Early SE provides an audit trail from the users’ capability gaps and needs, through concept selection, high-level system requirements refinement, and documentation of development plans.

Numerous studies and reports (most recently from the Government Accountability Office [GAO] and the “Pre-Milestone A and Early-Phase Systems Engineering” study committee of the National Research Council [NRC]) have documented the need for greater emphasis on SE in the early stages of capability planning and system acquisition. Figure 1.1 depicts the acquisition life cycle per DoDI 5000.02, Dec 2008. (Milestone reviews for DoD space programs governed by National Security Space policy and guidance do not align exactly with the DoDI 5000.02 timeline, and the phase names differ slightly).

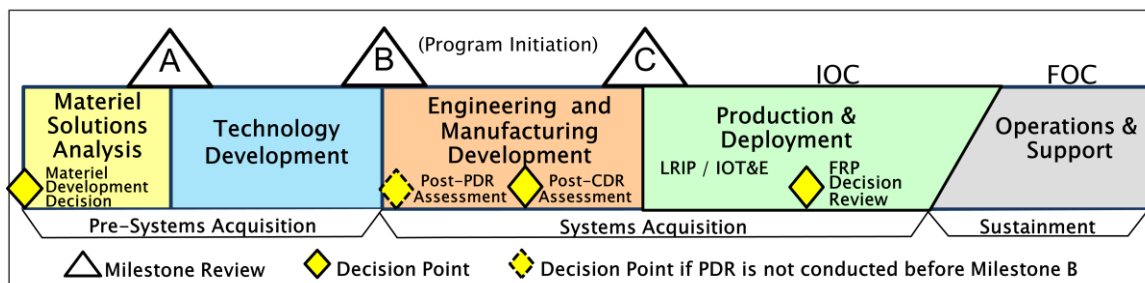

Figure 1.1 DoDI 5000.2 (Dec 2008) acquisition life cycle.

Application of SE to activities before and during the Materiel Solutions Analysis phase (Materiel Development Decision [MDD] through MS A) assists in the translation of capability need statements into requirements, prior to using traditional SE to develop design solutions from these requirements. The process is functionally almost identical to classical product-focused SE; the primary distinction is that it starts with a capability need rather than a defined requirement. It also produces few if any tangible physical output products beyond artifacts such as concept data packages and decision documents for the technical knowledge base. Another difference, almost axiomatic, is that this early instantiation of SE is primarily an organic activity: while understanding “the realm of the possible” in industry is important, the concept development community--acquirers, operators, testers, maintainers, technical specialists, and budgeters, to name a few key members--should not look at specific solutions early in the life cycle.



“Early SE” can be divided into four segments:

- Capabilities-Based Assessment (CBA)
- Concept Exploration and Refinement (CER)
- Preferred System Concept (PSC) maturation
- Technology Development (TD)

Figure 1.2 depicts the first two segments. It is important to note the significant overlap and concurrency between CBA/JCIDS and the Trade Space Characterization phase of CER.

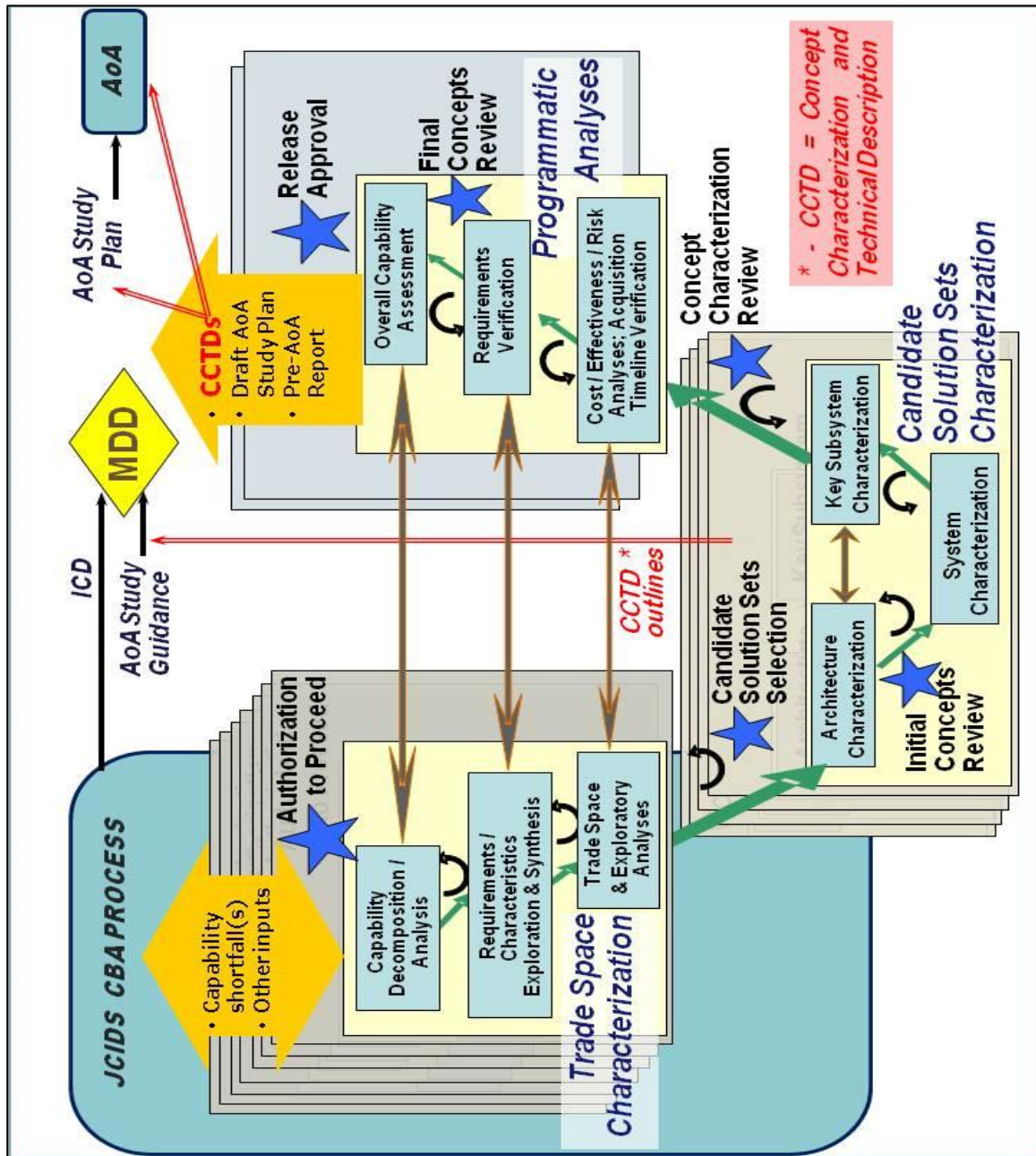

Figure 1.2 Early Systems Engineering.

### 1.3 Organizational Roles

CBA/JCIDS initiates the early SE efforts. This process is owned by the using or sponsoring Major Command (MAJCOM), which leads team efforts to identify any capability shortfalls, scope the trade space necessary to develop conceptual solutions, and identify potential solutions. The acquiring command, led by the concept development (typically XR) organizations, provides technical subject matter experts (SME) to assist the MAJCOM; Air Force Research Laboratory (AFRL) also assists in identifying the projected availability of technologies to help overcome the capability shortfalls. The MAJCOM is responsible for submitting JCIDS documentation; all team member organizations participate in development of supporting material and in reviews.

As the JCIDS and Tradespace Characterization processes approach the transition to Candidate Solution Sets Characterization, the sponsoring MAJCOM will typically turn over leadership to the acquiring command. An XR organization or program office cadre will usually assume leadership, with AFRL providing support. It is still necessary for the MAJCOM to have an active role, as they are the only organization that can interpret their requirements and approve any changes; they also advise on whether a potential solution can or will be funded. During this stage, the lead acquisition organization is responsible for completing documentation and preparing for any required reviews. Figure 1.3 shows typical relative levels of effort for the organizations.

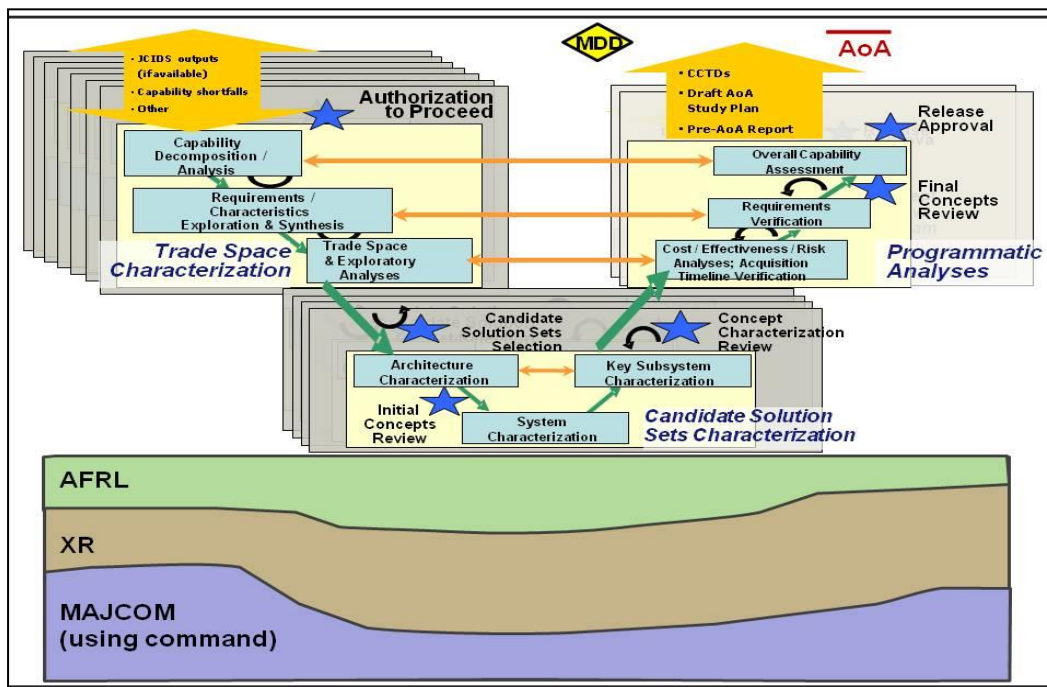

Figure 1.3 Relative levels of effort during CER.

The MAJCOM role increases during the Programmatic Analysis phase in preparation for chairing the AoA Study Team. While the acquiring command still has the lead, and AFRL continues to provide research support, both must work closely with the using command to ensure that the concept solutions satisfy MAJCOM requirements and meet user expectations. Again, the lead acquisition organization is responsible for completing documentation and preparing for required reviews.

The using MAJCOM provides the following expertise:

- A planning organization, typically A5 or A8, responsible for maintaining a balanced overview of the organization's top-level strategic situation. It ensures that all of the systems used by its operational (using) agencies form systems of systems (SoS) that work smoothly together to meet the current and future strategic needs of the organization. Measures of Outcome (MOO) usually come from a strategic agency point of view.
- An operations organization, typically A3, responsible for high-level system requirements, starting with operational requirements. This includes system usage scenarios, the Concept of Operations (CONOPS), and training. It must work with strategic agencies to ensure its current and future capabilities adequately address strategic needs, and must collaborate with other operating agencies to provide appropriate robustness (capability overlap). The Operations point of view is generally the source for Measures of Effectiveness (MOE), and may also provide some top-level Measures of Performance (MOP).
- A sustainment planning organization, typically A4, responsible for insuring that field supportability issues are properly addressed and integrated into the overall logistics support structure. Supportability MOPs such as reliability, maintainability, and training concerns come from a sustainment viewpoint.
- An Intelligence organization, typically A2, responsible for timely information regarding current and future capabilities and intentions of potential adversaries. Adversarial capabilities usually drive the establishment of system requirements (*i.e.*, MOPs) sufficient to circumvent or defeat them.

The acquiring command provides the following expertise:

- A development and acquisition organization, typically XR, responsible for translating high-level system needs into more detailed system-level information. With the help of all stakeholders, they generate and analyze alternative system concepts, and provide balanced estimates of effectiveness, performance, cost, schedule, and risk to assist the stakeholders in selecting preferred concepts. Risk estimates include assessing the impacts of implementing new technologies. Once a system concept is selected, the acquiring command generally establishes a program office to oversee development, procurement, deployment, and continued life cycle evolution of the system. The concept developers and analysts provide key elements of the technical knowledge base to this program cadre, and should remain available to provide supporting technical and programmatic rationale throughout the system life cycle. Most technical requirements (MOPs) come from concept and system development organizations.
- A technology organization, typically AFRL, working with acquisition organizations to ensure that relevant technologies are considered, and that they are compatible with the desired time frame and expressed acceptable risk levels. They can suggest new approaches made possible by emerging technologies, as well as technologies that will improve or enhance a system's effectiveness or performance and/or reduce its cost. They are also responsible for estimating the risks and uncertainties associated with new technologies and, in conjunction with system analysts, help assess their impacts. Conversely, they will gain insight as to user/operator needs and will be able to better focus their technology roadmaps.

The acquiring command will also typically arrange for contractor and user involvement.

## 1.4 Continuous Capability Planning Overview

Continuous Capability Planning (CCP) integrates the MAJCOM-led Capabilities-Based Planning (CBP) process and the acquisition-led Development Planning (DP) process. It is designed as a rigorous and iterative high-level activity, and is intended to ensure that properly articulated capability needs are met through development of robust concepts, appropriate allocation of requirements, and delivered warfighting systems. Achieving high-confidence programs is a result of systematically moving from capability needs to allocation of functions to systems. The CCP process ensures linkages between system and operational requirements are addressed, understood, and maintained.

Ideally, AF requirements determination/validation is a disciplined process that starts with warfighter-identified capability needs and shortfalls coming out of JCIDS and the Capabilities Review and Risk Assessment (CRRA) process. It involves all operational, materiel command, and supporting stakeholders; and results in materiel solutions being identified, designed, and delivered to meet stated capability needs and shortfalls with speed and credibility.

The CCP (CBP and DP) effort includes support of the CRRA, CONOPS development, technology assessments, concept developments, and solution analyses. Properly executed, CCP will inform the decision-making process to both enable launching high-confidence programs and eventually verify that the fielded systems address stated capability needs. A critical aspect of CCP is the materiel commands' contribution to the CBP process, beginning with support to development of the Initial Capabilities Document (ICD); in addition to reacting to identified capability gaps, this also involves using forecasts of technology availability to proactively anticipate gaps and opportunities. CCP is structured to ensure integration of multiple acquisition, sustainment, and technology transition perspectives during development of prospective materiel solutions.

CCP provides a strategic framework in which MAJCOM, CRRA, and other capability needs are translated into actionable materiel solution sets. It includes, among others, the following efforts:

- Synchronizes planning via materiel solutions that fulfill validated capability needs through a System of Systems (SoS) strategy
- Supports definitions of future capability needs and operational requirements
- Defines and evaluates SoS alternatives concepts
- Sponsors trade studies that define effective, achievable system requirements
- Assesses technology maturity and risk drivers
- Identifies sustainment and life cycle cost issues
- Defines preferred concepts
- Develops executable acquisition strategies
- Assesses delivered vs. planned SoS capabilities (continuous capability assessment)

As a capability need is being identified and characterized, concept generation activities involve identifying and analyzing the operational context for which the need is articulated. Within that context, functional needs or capabilities are decomposed into architectural and system elements. The process is iterated through definition of lower level elements for various alternatives, and through a set of reviews culminates in selection and refinement of a preferred system concept.

## **1.5 System-of-Systems (SoS) Perspective**

SE practices have historically been described in the context of a single system, such as an aircraft or a munition or a satellite. However, much as these discrete systems are composed of multiple subsystems (*e.g.*, propulsion, navigation, electrical power, communication, etc.), they are almost always part of larger systems (*e.g.*, command and control, mission planning, integrated air defense, etc.). Such systems, created or defined by combining numerous individual elements to provide a capability, are commonly called a System of Systems (SoS). In the defense acquisition environment, SoS SE is applied when a materiel solution for a capability need described in an ICD cannot be provided by a single weapon system. The DoD Systems Engineering Guide for Systems of Systems offers a more detailed discussion of SoS SE Core Elements and emerging principles, and their relationship to traditional SE processes.

### **1.5.1 SE for SoS**

SoS SE deals with planning, analyzing, organizing, and integrating the capabilities of a mix of existing and new systems into a SoS capability. The construct may combine many interacting yet collaborative and autonomous systems. The mix of systems can include yet-to-be-designed, partly developed, and existing independent systems. Thus, individual systems' SE processes must often be changed to accommodate the unique considerations of overall SoS needs.

Development or evolution of SoS capability is seldom driven solely by a single organization, but generally involves multiple Program Executive Officers (PEO), Program Managers (PM), and operational and support communities. While each individual stakeholder group's objectives and organizational contexts shape its expectations with respect to the SoS, any one group may well have limited knowledge of the constraints and development plans for the other systems. Planners may not recognize every SoS stakeholder, or may not realize that a particular organization or group needs to be included in deliberations. In contrast, individual system stakeholders may have little interest in the SoS, may give SoS needs low priority, or may consciously resist SoS demands on their system. This complicates the integration and analysis tasks associated with navigating the plans and priorities of the constituent systems, along with their asynchronous development schedules, to successfully orchestrate evolution of the SoS toward SoS objectives.

### **1.5.2 SoS Architectures**

The architecture of a SoS is necessarily based on the SoS CONOPS; it encompasses the internal and external relationships, functions, and dependencies of all the constituent systems. This includes end-to-end functionality and data flow as well as communications. The SoS architecture provides the technical framework for assessing changes needed in the constituent systems or other options for addressing requirements.

When beginning development of a new system, designers and analysts can take a fresh and unencumbered approach to architecture. However, in developing SoS architectures, many if not all of the individual constituent systems contributing to the overall capability objectives are typically in place when the SoS is established. Their current states and plans are important considerations in identifying options and trades to balance SoS and system needs and constraints. Each system and program is generally at a different point in its life cycle, with its own distinct approach to capability evolution; therefore, a critical part of up-front SoS-level "Requirements Engineering" efforts is to reconcile conflicts among these strategies. Transition planning is critical to ensuring that all constituent systems remain operationally safe, suitable, and effective as their discrete capabilities and their contributions to the SoS evolve concurrently.

### **1.5.3 Interoperability and Design Considerations**

Interoperability as an objective is substantially axiomatic: weapon systems, support systems, and business and information systems must work together to deliver a capability at the integrated SoS level. While there is an equally self-evident corollary -- systems generally work better together when designed to do so -- the reality is that system behaviors and interactions reflect emergent behavior in response to real-time conditions. This may either have a positive or negative effect on SoS performance. For the SoS to function properly, all components of the SoS must work together to provide the desired end-to-end performance. However, since the boundaries of any SoS can be relatively ambiguous, it is essential to identify the critical set of systems that affect the SoS capability objectives and understand their interrelationships. This is particularly important because the constituent systems and elements of the SoS typically have different owners and supporting organizational structures beyond the SoS management.

### **1.5.4 SoS Modeling and Simulation**

Because of the characteristics of SoS, Modeling and Simulation (M&S) can be used to support SoS SE in a number of areas. Models can be effective means of understanding the complex and emergent behavior of systems that interact with each other. They can provide an environment to help the SoS SE team to create a new capability from existing systems, and to consider integration issues that can have a direct effect on the operational user. M&S can support analysis of architecture approaches and alternatives, and can also support analysis of requirements and solution options. If early models of the constituent systems of the SoS can be constructed and validated, better identification of potential problems is possible at early stages of the life cycle. Consequently, it is important to include planning for M&S early in the SE planning, including the resources needed to identify, develop, or evolve and validate M&S to support SE, Test and Evaluation (T&E), and eventual Verification and Validation (V&V).

## 2. Capability-Based Assessment (CBA)

CBA develops potential materiel and non-materiel concepts to address capability gaps and shortfalls, or to exploit new capabilities provided by new technologies. Although this phase is primarily governed by AFI 10-601 and the Joint Staff (J8) Manual for the Operation of the Joint Capabilities Integration and Development System, there are concepts that are developed without being vetted initially through the JCIDS process.

This guide is applicable for any concept no matter how developed. For those concepts that flow through the JCIDS process, HQ USAF/A5R and the operational MAJCOMs are the lead for this phase, with AFMC or AFSPC supporting as the Implementing Command. The Implementing Command roles are (AFI 10-601):

- Provides core members to High-Performance Teams (HPT) as appropriate for development of capabilities-based requirements documents
- Assists the lead command in developing and preparing AoAs and performing or contracting for concept studies funded by requesters
- Ensures M&S requirements are addressed within capabilities-based requirements.
- Provides assistance and guidance in sustainment planning and execution
- Coordinates on all capabilities-based requirements documents

A CBA flow diagram appears in Figure 2.1.

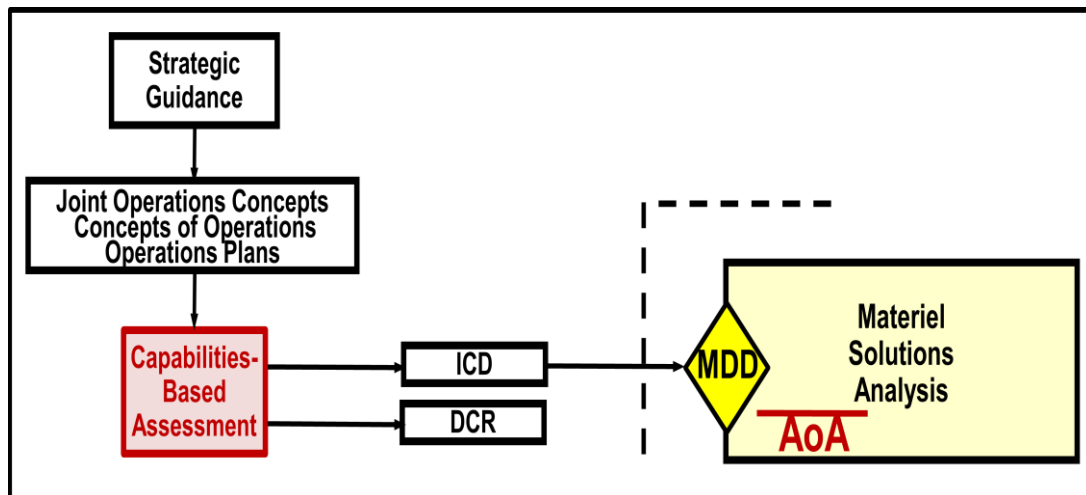

Figure 2.1. JCIDS Capability-Based Assessment (CBA).

DCR = DOT\_LPF Change Request (Doctrine, Organization, Training, Leadership and Education, Personnel, Facilities), *i.e.*, non-materiel means of addressing the capability need

### **3. Concept Exploration and Refinement (CER) (CBA to AoA)**

#### **3.1 Overview**

As the “heart” of early SE, CER provides for developing materiel solutions to warfighter shortfalls and refining the activities at the front end of the acquisition life cycle (ref DoDD 5000.1, DoDI 5000.02, and JS 3170). It is intended to enhance the quality and fidelity of proposed future military system concepts that may eventually be considered in an Analysis of Alternatives (AoA).

Each concept developed under CER will have been technically researched, analyzed, and evaluated against a validated set of mission-based requirements, and costed for the entire life cycle. Various architecture products, along with a Concept Characterization and Technical Description (CCTD) document, will capture the technical “pedigree” of each concept as it matures. The CCTD outline informs the AoA Study Guidance; the final CCTD will ultimately serve as the baseline System Requirements Document (SRD) and/or Technical Requirements Document (TRD) for the PSC at MS A; as such, it must be maintained under configuration control going forward out of the AoA. It can include recommendations for use of representative data and specific analytical models that may assist the AoA Study Team as well as those involved in PSC maturation. Refer back to Figure 1.2 for a depiction of CCTD linkages.

#### **3.2 Methodology**

The CER process uses common SE principles to develop and evaluate a variety of new materiel solutions to military shortfalls, and incorporates methods by which difficult technical problems are re-evaluated. CER works with identified inputs, outputs, and activities and includes a control function to ensure it stays focused.

As can be seen in Figure 1.2, CER consists of three major sub-processes:

- Trade Space Characterization
- Candidate Solution Sets Characterization
- Programmatic Analysis

Within the CER there are the following reviews:

- Authorization To Proceed
- Candidate Solution Sets Selection
- Initial Concepts Review
- Concept Characterization Review
- Final Concepts Review
- Release Approval

##### **3.2.1 Control Function**

It is essential that every concept development organization establish a management and governance structure with rigorous and documented controls for the CER activities.

##### **3.2.2 Inputs**

CER inputs begin with documented, high-priority user needs and shortfalls. Inputs also cast a broad net for existing “good ideas” that can be incorporated into the process at the appropriate times. A well-defined analytical agenda, including but not limited to key scenarios and evaluation criteria, is essential for later consistency. Finally, an easily searchable data repository to house all the inputs must be created and maintained.



Under JCIDS CBA, the appropriate MAJCOM organization identifies and develops requirements for future systems, identifies high-priority user needs and shortfalls, and creates system descriptions of material solutions with the potential to satisfy the stated requirements.

### 3.2.3 Concept Engineering Team

Concept Engineering teams are established to mature concepts through the CER process. Teams are identified to work a family of concepts, including integration of new or emerging technologies, and are not to be seen as advocates for any single technology or concept. Teams have an array of tools at their disposal, and may also develop and manage unique tools as appropriate. Each Concept Engineering team is responsible for creating and delivering all documentation and executing all Control Milestones and reviews.

Teams must tailor their membership to fit the particular need/shortfall being addressed, as well as the phase of the process in which they are currently working. In general, the following represents the membership of a typical Concept Engineering team. This is not meant to be an all-inclusive list

- Team Lead (recommend that this be a qualified, experienced Systems Engineer)
- Mission area specialist(s)
- System Wing representative(s)
- Science & Technology specialist(s)
- Engineering and technical support
- User representative(s), operations
- User representative(s), sustainment
- Logistics Center representative(s)
- Test & Evaluation / Verification & Validation representative(s)
- Modeling & Simulation specialist(s)
- Cost Analysis specialist(s)
- Industry partners
- Program Management expertise (cost, schedule, performance, illities, etc.)

### 3.3 Tradespace Characterization Phase

Figure 3.1 shows that this first phase of the process is initiated at the Authorization to Proceed Review, and ends when a series of credible system concepts to address those shortfalls has been documented and approved to move forward at the Candidate Solution Set Selection Review.

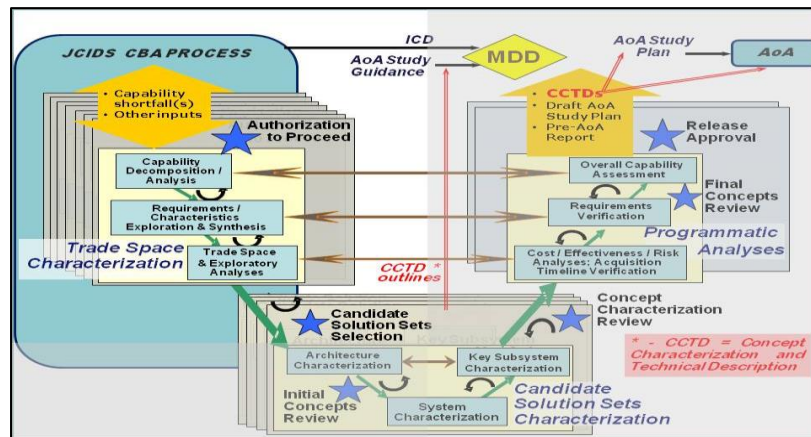

Figure 3.1. Tradespace Characterization Portion of CER.

**Tradespace Characterization re-structures user needs into quantifiable tradespace boundaries while collecting potential solution ideas, filters the collected data to the most promising subset, and applies various creative methods to establish a number of solutions.**

### 3.3.1 Authorization to Proceed Review

The management and governance structure (ref. 3.2.1) will establish boundary conditions for the Concept Engineering team evaluations, to allow the remainder of the process to focus on specific areas of interest. Some factors to be considered include user priorities, ongoing development activities, maturity of key technologies, and other high-level criteria.

Outputs of the initial decision review are:

- Establishment of a focus area (i.e., a documented list of capability requirements and strategic guidance)
- Identification and creation of a Concept Development Team, to include the Team Chief and team membership
- Identification of a set of expectations the Team will work toward (including schedule)
- Identification of resources the Team will have access to (funding, manpower, tools, etc.).

### 3.3.2 Capability Decomposition and Analysis

This critical step begins with a prioritized list of military needs or shortfalls. It ensures that developed system concepts address actual real-world military problems; it should also set the frequency of the development cycles to coincide with organizational priorities and resources. The CCTD (Para. 3.1) is initiated during this step to capture decisions and supporting rationale.

Mission areas/shortfalls are further decomposed, quantified, and focused. Other factors like available funding, on-going related activities, etc. are evaluated. Existing system requirements can be used as a baseline to help bound the tradespace.

**The most important part of the process is taking the initial input requirement and decomposing it into quantifiable tradespace boundaries. The broader the tradespace, the longer the process will take; in contrast, if the tradespace is limited too far, it will yield a single point design. The balance between these extremes is based on the time, effort, and resources dedicated to a particular iteration.**

#### EXAMPLE:

- Stated mission task:  
*Provide the capability to Find/Search, Fix, Track, and Characterize all man-made space objects, space events (space launches, maneuvers, breakups, dockings, separations, reentries and decays) and space links (ground to space, space to space, space to ground) for near-Earth and deep space orbits.*
- Decomposed Concept Engineering mission task:  
*Provide the capability to Find/Search, Fix, Track, and Characterize all man-made space objects in Geo-stationary/Geo-synchronous orbits.*

The Concept Engineering Team must also establish an initial requirements baseline. Documents such as an ICD, a CONOPS, or a Capstone Requirements Document can form the basis for selecting a minimum set of requirements.

The team should compare the identified requirements baseline to known systems, capabilities, and/or technologies. How each identified system and/or technology performs against these requirements can corroborate the stated descriptions of current shortfalls, and can provide early indications of which (or whether) new or emerging technologies represent opportunities to address those shortfalls. Much of this effort parallels JCIDS CBA activities.

### **3.3.3 Requirements/Characteristics Exploration and Synthesis**

During this phase, with user needs/shortfalls stated in objective form, the Concept Engineering Team begins to synthesize the decomposed/quantified user requirements in terms of potential system solutions (both materiel and non-materiel) for further development and evaluation.

This effort requires extensive collaboration between a number of organizations, and personnel with various backgrounds and technical abilities. Relationships to industry partners, the Defense Technical Information Center (DTIC), Science and Technology (S&T) communities (including AFRL), universities, warfighters, and other government agencies will enrich the talent pool.

Potential solutions will be developed to similar top levels of detail. Specifically, various products will be created for each concept solution. These products include a High Level Operational Concept Graphic (OV-1) with an Operational Concept Narrative. Anticipated operational, system, and/or technical trades must be documented in the CCTD, along with supporting rationale for all decisions based on trade studies actually performed.

With a clear understanding of the problem(s) to be solved, the Concept Engineering Team defines a number of different approaches (both materiel and non-materiel) to satisfy the decomposed shortfall developed in the previous step.

Previously collected ideas may be applicable to the shortfall; in addition, new solutions should be solicited through events such as industry days or holding group brainstorming sessions. In order for these to be effective, a minimum information set for each solution should be solicited and provided. Solutions should be framed within the bigger picture of a complete system or SoS to include all Level 2 elements of a standard WBS.

### **3.3.4 Trade Space and Exploratory Analysis**

The next step is to compare and contrast the candidate concept families with respect to the user-identified needs and shortfalls, and to each other. Among other factors, this involves rough estimates of each solution's feasibility in terms of implied performance (coverage, bandwidth, speed, power, throughput, etc.) requirements, doctrinal ties, outside resources, and organizational linkages needed to fully field and operate each system concept. Initial mission parameters, applicable physical laws, and engineering rules of thumb should be used in order to uncover any significant problems that would warrant shelving a particular system concept. Should a system concept be shelved, the rationale for doing so must be documented in its CCTD.

Next, mature solutions must be separated from immature ones, and candidate solutions that offer little or no military value must be screened out and documented. Maturity of the technologies needed to construct and field each respective system concept must be assessed. Each system should be characterized as to its development horizon: near-term (generally fielded within 0-8 years); mid-term (generally 9-15 years); or far-term (generally 15-23 years). By definition, near-term concepts consist entirely of technologically mature elements (technology readiness level [TRL] 6 or greater). System concepts classified as mid- or far-term solutions may rely on materials and/or technologies with a current TRL less than 6; however, they must be accompanied by a reasonable technology maturation strategy to assure that needed technologies will be available in time. Any system concept with TRLs that do not match the development horizon must be shelved or reworked, with rationale documented in its CCTD.

Technology maturity issues that present roadblocks to otherwise promising systems should be translated into technology needs statements that can later be relayed to appropriate S&T communities for research.

Another aspect of Tradespace Characterization deals with establishment of initial measures of military utility (MOMU). Initial MOMUs will define how the fielded system impacts military operations through fairly straightforward metrics (typically casualties, dollars, or time saved in a military engagement). First-order models or intelligent estimates are used to derive these assessments. Even though subsequent high-fidelity simulations will validate assumptions, this initial step should eliminate solutions of little or no military value from further analysis. At the conclusion of this step, each remaining potential solution must have an OV-1 and an Operational Concept Narrative included in its individual portfolio.

Finally, potential solutions deemed still viable must be scored and ranked according to a set of parameters, such as cost, technology risk, time to field, MOMUs, etc. Numerous evaluation and scoring tools are available to perform these tasks.

### 3.3.5 Candidate Solution Set Selection

With the establishment of candidate solutions shown to address the decomposed shortfall and capture stated user needs, the Candidate Solution Set Selection review examines the information collected during Tradespace Characterization. This includes user needs and shortfalls as documented in the Mission Tasks, the CCTD, and any recommendations from the Concept Engineering Team Chief. The most promising solution(s) will be selected for continuation into Candidate Solution Sets Characterization. Downselect criteria should include (but not be limited to) how well each solution satisfies stated user needs and/or shortfalls; the technology maturity path and associated fielding timeframe for each solution; the existence or absence of similar efforts ongoing elsewhere in the military or industry; and resource availability for the next phase.

Outputs of the Candidate Solution Set Selection are an approved set of promising solutions for continued development, and an updated set of expectations for future work (including schedule), as well as resources the Team will have access to (funding, manpower, tools, etc.).

### 3.4 Candidate Solution Sets Characterization Phase

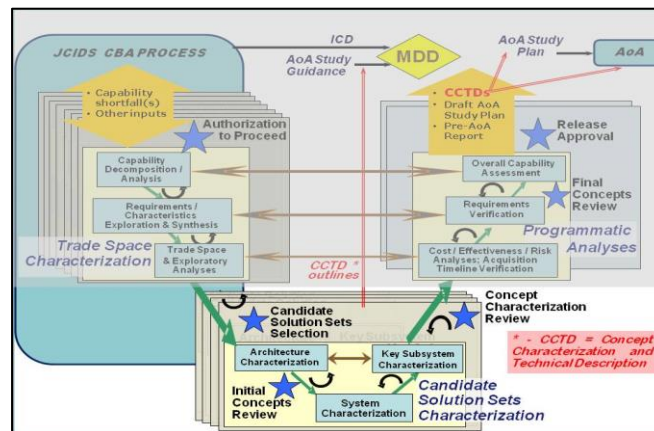

Figure 3.2. Candidate Solution Sets Characterization Phase of CER.

This second phase addresses the further characterization and refinement of the concepts that successfully passed the Candidate Solution Set Selection. The three steps in this phase represent a traditional systems engineering approach to analyze and refine system concepts. As can be seen in Figure 3.2, this phase is not intended to reduce the solution set to a single concept; instead, the goal is to bring as many viable candidates or families of candidates as possible to the Concept Characterization Review.

### **3.4.1 Architecture Characterization**

The OV-1 developed in previous steps roughly identifies the number and types of system nodes (air, space, ground, etc) within each system concept, and the nature of the links (communication and other) between each of those nodes. Many system concepts may require other key resources (such as navigation, training, intelligence/surveillance/reconnaissance [ISR], communications, logistics, or space launch systems). It is important to verify that each supporting resource referenced by the system concept actually exists; otherwise the system itself must provide the supporting function in the Level 2 WBS. Interfaces between nodes must be recognized as an important design factor by this point, and order-of-magnitude estimations for interface requirements must be established and validated. Characterizing the complete SoS architecture this way ensures the system concept maximizes the degree of horizontal integration, thus avoiding wasteful duplication of capability. Documentation includes an Organizational Relationships Chart (OV-4), an Operational Node Connectivity Description (OV-2), and an Operational Activity Description (OV-5); an Operational Information Exchange Matrix (OV-3) is recommended if the concept can be described at that level of detail.

Once all the concept nodes and their interfaces have been analyzed, investigation of the system's potential to address stated needs/shortfalls can now begin. Simulating the concept system may uncover secondary missions for the new system, expose potential vulnerabilities to enemy countermeasures, and provide insight into satisfying original warfighter shortfalls. M&S specialists may be able to develop or provide access to a suitable wargame as an opportunity to exercise the concepts in a representative future scenario.

### **3.4.2 Initial Concept Review**

This review is typically chaired by the Technical Director or equivalent of the concept development organization. Documented clarifications and recommendations from the user perspective should be considered guidance for system implementation, as well as (potentially) added to future cycles. The user may also suggest realistic scenarios and tactics for future wargaming or Military Utility Analysis (MUA) of the system.

The Concept Engineering Team will recommend one of three actions: move the concept forward to the next step in the process; shelve the concept due to unacceptable vulnerabilities and/or operational issues (such as an unreasonable logistics tail, failure to meet the user's timeline, etc.); or return the concept to the Tradespace Characterization Phase for further definition and/or modifications. All assumptions and results of all simulations will be documented in the appropriate Concept Portfolio for future reference, and the CCTD must be updated.

Outputs of the Initial Concept Review are: permission to proceed for those concepts approved by the management/governance structure; identification of concepts to be shelved or returned for additional work; identification of expectations for future Concept Engineering Team work; identification of resources; and an updated and approved CCTD.

### **3.4.3 System Characterization**

System Characterization includes common “front end” SE activities. Concepts are defined to a further level of design fidelity, and can then be re-assessed against the requirements developed earlier. Performing this assessment allows different concepts, as well as different configurations of the same concept, to be evaluated against one another.

System Characterization activities provide the first technical steps toward a TRD/SRD, which will capture the traceable justification for design attributes, system configurations, and trade studies. All design decisions must be traceable to user needs; documentation must note any user requirements that exceed current technological capabilities.

Outputs of this step for each candidate solution should include a Systems Interface Description (SV-1), a Systems Functionality Description (SV-4), and a System-Systems Matrix (SV-3). The CCTD must also be updated.

### **3.4.4 Key Subsystem Characterization**

The Concept Engineering team must address all WBS Level 2 elements for technology viability. Initially, each Level 2 element should be broken down to Level 3. Through research of past and current technical capabilities, trends can be established to assist the team in identifying which sub-systems (Level 3 elements) can be readily obtained, and those which may require further development. Elements not yet available must be assessed to determine if maturation plans for any critical enabling technologies will support the system fielding timeframe.

Where a technology maturation path does not appear to align with needs, the disconnect(s) must be documented as technology needs for the Science and Technology (S&T) community. In these cases, the team should evaluate alternative elements that do not rely on immature technologies for incorporation into system/subsystem architectures. Ultimately, candidate systems deemed unfieldable due to technology issues will be recommended for elimination at the Concept Characterization Review, or returned for further analysis if alternate approaches appear viable.

Outputs from this step include a System Performance Parameters Matrix (SV-7), a Systems Technology Forecast (SV-9), the Engineering Analysis, and a Level 3 System WBS for each candidate system. The CCTD must also be updated.

### **3.4.5 Concept Characterization Review**

The Concept Characterization Review represents a quality control check of the candidate system design(s), by reviewing the information collected during Key Subsystem Characterization and the updated CCTD for continuation of selected concepts into the Programmatic Analysis phase of the process. Criteria include, among other factors, the level of satisfaction of stated user needs or capability shortfalls; the fidelity and quality of each candidate design; and funding and manpower availability for further investigations. Candidate solutions may be approved to move forward to the Programmatic Analysis phase, or sent back for further work.

Outputs of the Concept Characterization Review are an approved set of concept solutions (to WBS Level 3 where possible) for continued development, an updated CCTD, an updated set of expectations for future work, and identification of resources.

### 3.5 Programmatic Analysis Phase

The steps of this leg, depicted in Figure 3.3, ensure realistic acquisition resources, schedules, and costs are defined for each candidate solution. The Concept Engineering team conducts extensive requirements verification and capabilities assessments to investigate the military utility and programmatic viability of each approved concept for potential future investment.

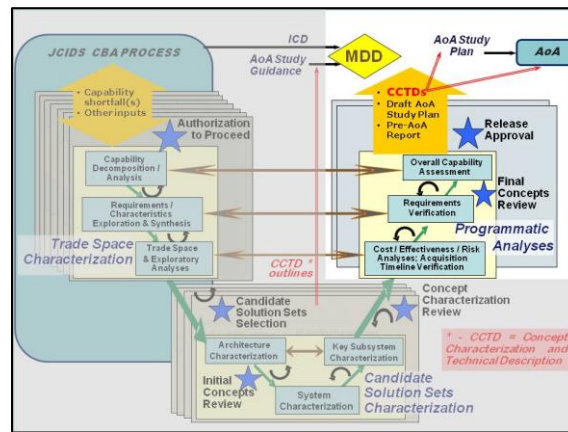

Figure 3.3. Programmatic Analysis Phase of CER.

#### 3.5.1 Cost/Effectiveness/Risk Analysis; Acquisition Timeline Verification

Costing is a critical component of this step as it can have a significant influence on the timing of acquisition milestones. Cost estimation is performed by certified costing personnel in close coordination with the Concept Engineering team. The technical fidelity added through the previous phases should yield higher fidelity cost estimates. Level 3 System and Program WBSs must be provided to the Concept Engineering team. The costing personnel will also provide an operational WBS (including manning, facilities, training estimates, etc.).

#### 3.5.2 Requirements Verification

Mature concepts that reach this step receive a full military utility analysis and are quantified in their ability to satisfy the original warfighter shortfalls established at the beginning of the process. The products include the MUA Report and the final CCTD which contains all products and analysis for a given family of concepts as well as all management/governance structure review/approval presentations, materials, and findings. Once approved for release, the concepts are moved to a database for use by authorized organizations.

#### 3.5.3 Final Concepts Review

As with the Initial Concepts Review, the Final Concept Review is typically chaired by the Technical Director or equivalent of the concept development organization. This review provides a top-level review of acquisition and costing data produced in the previous step, and ensures the system concept(s) is/are ready to progress further.

Outputs of the Final Concept Review are an approved set of costed concept solutions/acquisition approaches for continuation, an updated and approved CCTD, an updated set of expectations for future work, and identification of resources.

### **3.5.4 Acquisition Timeline Verification/Capability Assessment**

Acquisition objectives set approximate milestones for system development and fielding grouped into three main areas: Design Time, Build Time, and Useful Operations Time. Each period contains required events, reviews, and deliverables as specified in DoDD 5000.1, DoDI 5000.02, and National Security Space policy and guidance. Refer to the *Acquisition Community Connection* at <https://acc.dau.mil>.

At the conclusion of this step, each candidate solution will have a top-level development plan and schedule, a Level 3 Program WBS, a cost estimate that includes most Level 3 elements, an Integrated Dictionary (AV-2), an Operational WBS, and a Security Classification Guide.

### **3.5.5 Release Approval Milestone**

Based on information in the CCTD and the recommendation of the Concept Engineering Team Leader, the concept will be approved for release, shelved, or sent back for additional work. Concepts that pass this review are considered mature enough to be considered for inclusion in an AoA.

### **3.5.6 Outputs**

At the conclusion of the CER process, the CCTD contains all products for a given concept. Outputs include inputs for the AoA, either directly or indirectly through the DoDAF products in the CCTD. A list of technology needs/shortfalls discovered during the process that either eliminated promising concepts or create significant challenges for released concepts is especially important to AFRL and industry, and may be considered “tech pull.” Much of this material will be documented in a Pre-AoA Report which will capture the complete history of the development efforts for a family of concepts going forward into the AoA. In addition, any lessons learned should be documented for consideration in CER updates/modifications for future cycles.

## **3.6 Documentation**

Regardless of the method used to depict the information, the AoA requires clear descriptions and definitions of the concepts/solutions under development. Typical information includes:

- Decomposed ICD/CONOPS requirements
- Evaluation of system threats with respect to risk
- Collection/decomposition of previous studies
- Evaluation of existing systems capabilities and shortfalls (with respect to ICD)
- Research database of potential alternatives/technologies
- Identification of mission tasks/OV-1
- Identification of input assumptions
- Architecture vision
- Supplemental modeling and simulation (M&S) tool set
- Identification of potential new requirements
- Identification of funding profile
- Cost breakdown for researched equipment



### 3.6.1 Concept Characterization and Technical Description (CCTD) Document

A CCTD captures the analytical basis of a concept. It describes all parametric and tradespace studies performed over the concept’s lifetime, and should also include links to supporting documentation and other deliverables. The CCTD contains documentation of every attribute of the concept, so that its “pedigree” – the rationale for all decisions made during the development efforts – is clearly traceable in the final product. As a pre-acquisition system description, it is not expected to be at a level of detail commensurate with the technical description of a program of record. However, it serves as the starting point for the PSC requirements documents developed in support of the MS A decision, and should be placed under configuration control after completion of the AoA. See Annex A for the recommended CCTD format.

The Concept Engineering Team has overall responsibility for preparation of the CCTD, although various organizations provide important content. For example, the operating MAJCOM should detail the mission description and CONOPS; critical technologies and technology maturation paths should reflect input from the cognizant AFRL directorate(s).

The fidelity and maturity of the CCTD will vary depending on how the intended use of the concept. Content may be at a high level if the concept is developed to support strategic planning; however, it will necessarily be more detailed for a late-stage concept going into an AoA.

### 3.6.2 Architecture Products

The DoD Architecture Framework (DoDAF) identifies 27 “views” in four categories (All, Operational, System, and Technical) that are used to develop and describe system and SoS architectures. While the full set of DoDAF products is generally unnecessary for purposes of early SE, many “views” are highly relevant when maturing concepts for the purpose of an AoA. A number of these products identified in prior steps are actually used throughout the process as benchmarks to communicate concept maturity and performance as the concept(s) gain technical fidelity and receive approval to progress to further development stages. Principal DoDAF products that support concept development are listed in Table 3.1.

<b>Operational (OV)</b>	<b>Systems (SV)</b>	<b>All (AV)</b>
<b>1:</b> High Level Operational Concept Graphic	<b>1:</b> Systems Interface Description	<b>1:</b> Overview Summary
<b>2:</b> Operational Node Connectivity Descriptions	<b>3:</b> System-Systems Matrix	<b>2:</b> Integrated Dictionary
<b>3:</b> Operational Information Exchange Matrix (recommended if level of detail definition permits)	<b>4:</b> System Functionality Description	
<b>4:</b> Organizational Relationships Chart	<b>6:</b> System Data Exchange Matrix	
<b>5:</b> Organizational Activities Model	<b>7:</b> System Performance Parameters Matrix	
	<b>9:</b> Systems Technology Forecast	

Table 3.1. DoDAF views incorporated into the CER process.

### **3.6.3 Other Products**

All information collected at the start of Trade Space Characterization is organized by defining mission tasks and a list of decomposed requirements, and placed in the Concept Repository for future use. Note that this information can be either specifically linked to the user need/shortfall being addressed during the current cycle, or identified as unrelated. The goal is to capture all information relevant to the process regardless of applicability to a specific effort. In this way, information will already be available at the start of CER activities to address future shortfalls.

When appropriate, a Security Classification Guide for the individual concept or family of concepts must be created during this phase. Careful attention must be paid to the security classification of all materials related to the shortfall, as well as the products developed during execution of the process. In the early phases, security classification should be based upon existing classification guides as well as unit guidance.

### **3.7 Repository**

Key to the execution of the process is the use of a centralized clearinghouse of data for the process itself; this includes templates, background, educational materials, compliance documentation for each role, security compliance criteria, etc. The Concept Engineering Team should also populate the repository with raw data collected at the start of and during each cycle; and specific definitions, analysis, evaluations, and reports associated with each set of concepts. Concept engineering tools should also be listed and detailed here, along with interfaces to outside organizations or specialized bodies of knowledge.

#### 4. Post-AoA Phase (AoA to MS A)

The goal of this phase is to mature the PSC into a stable, producible, testable, supportable, and affordable program. PSC maturation efforts are characterized by the planning necessary to ensure a high confidence of program success; outputs are the Technology Development Strategy (TDS), the program SEP, the T&E strategy, the initial TRD/SRD, and any Requests for Proposal (RFP) for contractor work (such as prototypes) to be performed. The TDS is the foundation for the Acquisition Strategy (and eventually the Life Cycle Management Plan [LCMP]); it contains significant detail on program execution during the TD phase, but also documents early planning for post-MS B efforts. Therefore, it must include all activities necessary to successfully complete the TD phase.

The primary system elements and key subsystem elements described in the CCTD morph into the technical content of the TRD/SRD, which constitutes the initial technical baseline. As such, the CCTD should be placed under configuration management after acceptance of the AoA Final Report. As PSC maturation proceeds, the user's requirements will mature (*i.e.*, they will be added to or subtracted from, or revised in description). The pre-acquisition technical baseline will continue to evolve to more clearly define the PSC and adapt to the changing requirements. Managing the baseline will reduce the probability of requirements creep, prevent surprises at MS A or B when cost and schedule estimates are higher than originally planned, and allow more intelligent budgeting for the TD phase and the eventual program.

Key TD efforts include:

- Exploring the feasibility of the operational requirements and maturing the ICD into a final Capability Development Document (CDD)
  - o Conducting prototyping, demonstrations, and analyses to provide high confidence operational and system requirements
- Mitigating risks (technical and programmatic) to the level necessary to support a favorable MS B decision
  - o Establishing risk handling plans to ensure high probability of program success
- Developing a preliminary design of the PSC that is feasible, affordable, and will meet operational requirements
  - o From the CCTD, developing a system specification that flows to the lowest level of design and is fully traceable to the operational requirements (CDD)
- Determining the affordability and military utility of the preliminary design before committing to full system development
  - o Conducting prototyping and preliminary design

##### 4.1 Risk

Risk management is the heart of technical and SE planning during this phase and a critical first step toward affordable, manageable, and executable Technology Development phase efforts. Risks should be assessed and managed as described in the DoD Risk Management Guide and the AF Risk Management Guide (AFPAM 63-128). Risk assessments accomplished as part of the AoA should serve as the starting point for analysis during PSC maturation; those assessments will need to be further refined, and approaches to manage risks rated medium or higher will need to be identified.

Two key tools for risk mitigation are prototyping and competition. DoDI 5000.02 requires all programs regardless of ACAT to plan for prototyping and competition during the TD phase; this planning must be included in the TDS. The risk assessment described above should form the basis for the selected prototyping and competition approach. Prototyping is highly effective at:

- Reducing technical risks to include maturing technology, identifying and mitigating integration risks, controlling manufacturing and sustainability risks
- Evaluating operational and system requirements for feasibility, suitability, and affordability
- Minimizing risk of cost growth due to unknowns in design, assembly, and integration

Competition is useful for:

- Encouraging creativity and identifying alternative suppliers of capabilities to meet the PSC requirements
- Obtaining and comparing alternative approaches to the PSC
- Addressing programmatic risks such as responsiveness to program office direction, potential performance shortfalls, and cost growth due to a “captive audience”
- Strengthening the Government’s bargaining position on issues like data rights, per unit cost, and “in-scope” determinations
- Assessing contractor qualification and ability to perform

It is believed that, in most cases, competition and prototyping can be used together to enhance the effectiveness of risk mitigation efforts. However, in the event that the anticipated return on investment for these activities is insufficient, the Milestone Decision Authority (MDA) may elect to relieve the requirement.

Other risk management tools include modeling and simulation, analysis, demonstrations (*e.g.*, brassboards, breadboards, engineering models, etc.), identification of alternative or “off-ramp” technologies, and contracting strategies (including contract type, award/incentive fee approach, etc.). The emerging program technical team should engage with their management, as well as representatives from key functional organizations, AFRL, the using MAJCOM(s), and other stakeholders, before implementing specific tools or approaches.

Risk handling plans must identify the responsible parties; specific actions that will be taken to reduce risk and the anticipated level of risk reduction each will provide; and the schedule of activities. Where applicable, they should briefly describe the activities that will be required in later acquisition phases to ensure the system will meet operational and system requirements. When complete at the end of this phase, the SEP and TDS together should capture an integrated risk management approach that will be used to address all identified medium and high risks (both technical and non-technical) during the TD phase.

#### **4.2 Other Maturation Activities**

Key activities associated with maturation of the PSC toward the MS A decision include the following, which will be discussed in more detail in a future issue of this Guide:

#### **4.2.1 Functional Analysis and Allocation**

#### **4.2.2 Defining Interfaces**

#### **4.2.3 Trade Studies**

#### **4.2.4 Models**

#### **4.2.5 Metrics**

#### **4.2.6 Documentation**

Specific documents must be developed and approved for a favorable MS A decision. These include the following:

- AoA Report
- TDS
- Acquisition Strategy (to include competition)
- Technology Maturation Plan (to include prototyping)
- Sustainment Plan
- Test Plan
- SEP
- RFP (if being approved by MDA)
- TRD/SRD
- ICD
- WBS
- Affordability Assessment
- Initial CDD
- Cost and Manpower Estimate
- System Threat Assessment Report

A number of technical and programmatic reviews held during the latter part of the MSA phase are detailed in the CCP Guide.

## ABBREVIATIONS AND ACRONYMS

ACAT – Acquisition Category  
ADM – Acquisition Decision Memorandum  
AF – Air Force  
AFI – Air Force Instruction  
AFRL – Air Force Research Laboratory  
AFROCC – Air Force Requirements for Operational Capabilities Council  
AoA – Analysis of Alternatives  
AV – All View  
CBA – Capabilities-Based Assessment  
CBP – Capabilities-Based Planning  
CCP – Continuous Capability Planning  
CCTD – Concept Characterization and Technical Description  
CDD – Capability Development Document  
CER – Concept Exploration and Refinement  
CJCS – Chairman of the Joint Chiefs of Staff  
CONOPS – Concept of Operations  
CR – Capability Review  
CRRA – Capabilities Review and Risk Assessment  
DAPA – Defense Acquisition Performance Assessment  
DCR – DOT\_LPF Change Request  
DOT\_LPF – Doctrine, Organization, Training, Leadership and Education, Personnel, Facilities  
DoD – Department of Defense  
DoDAF – Department of Defense Architecture Framework  
DP – Development Planning  
DTIC – Defense Technical Information Center  
EMD – Engineering and Manufacturing Development  
FAA – Functional Area Analysis  
FNA – Functional Needs Analysis  
FSA – Functional Solutions Analysis  
GAO – Government Accountability Office  
HPT – High Performance Team  
ICD – Initial Capabilities Document  
IMP – Integrated Master Plan  
IMS – Integrated Master Schedule  
IPT – Integrated Product Team  
JCIDS – Joint Capabilities Integration and Development System  
JROC – Joint Requirements Oversight Council  
LCMP – Life Cycle Management Plan  
MAJCOM – Major Command  
MDA – Milestone Decision Authority  
MDD – Materiel Development Decision  
MOE – Measure(s) of Effectiveness  
MOMU – Measure(s) of Military Utility  
MOO – Measure(s) of Outcome

MOP – Measure(s) of Performance  
MS – Milestone  
MSA – Materiel Solutions Analysis  
MUA – Military Utility Analysis  
M&S – Modeling & Simulation  
NRC – National Research Council of the National Academies  
OV – Operational View  
PEO – Program Executive Officer  
PM – Program Manager  
PSC – Preferred System Concept  
RFP – Request for Proposal  
S&T – Science and Technology  
SE – Systems Engineering  
SEP – Systems Engineering Plan  
SoS – System(s) of Systems  
SV – Systems View  
SRD – System Requirements Document  
T&E – Test and Evaluation  
TD – Technology Development  
TDS – Technology Development Strategy  
TEMP – Test and Evaluation Master Plan  
TRD – Technical Requirements Document  
TRL – Technology Readiness Level  
V&V – Verification and Validation  
WBS – Work Breakdown Structure

**ANNEX A**  
**Concept Characterization & Technical Description (CCTD) Format**

**NOTE:** Main (bold) subjects are mandatory; sub-topics should be included as appropriate for the concept under development, and descriptive detail should be consistent with the concept's level of maturity/fidelity/granularity at any given time. Design and performance parameters for identified studies, analyses, and/or experiments should be selected on the basis of relevance to the concept, mission description, etc.; approaches and assumptions should reflect the initial focus of technical planning. This document is not expected to be at the level of a formal submittal such as a milestone review product.

- 1. Mission / Capability Need Statement / CONOPS**
- 2. Concept Overview / General Description**
- 3. Trade Space Definition / Characterization**
  - 3.1 Top-Level Architecture
  - 3.2 Principal Interfaces
  - 3.3 Operating Regime
  - 3.4 Key System Parameters
- 4. Studies, Analyses, Experiments**
  - 4.1 Parametric Studies (e.g., weight, power, cooling, throughput)
  - 4.2 Analyses (e.g., HSI considerations, supportability concepts)
  - 4.3 Experiments
  - 4.4 Conclusions
- 5. Concept Characterization / Design**
  - 5.1 Common Analysis Assumptions
  - 5.2 Operating Regime
  - 5.3 Interfaces / Interoperability / System-of-Systems Approach
  - 5.4 Critical Subsystem Design and Sizing
  - 5.5 Supportability / Sustainment Features
  - 5.6 Configuration Summary
  - 5.7 Analysis Results
  - 5.8 Concept Design Conclusions (Capability Description)
- 6. Program Characterization**
  - 6.1 Critical Technologies
  - 6.2 Technology Maturation Approach
  - 6.3 Test & Evaluation / Verification & Validation Approach
  - 6.4 Prototyping Approach
  - 6.5 Manufacturing / Producibility Approach
  - 6.6 Sustainment / Supportability Approach
  - 6.7 Schedule Assumptions
  - 6.8 Cost Analysis Assumptions
  - 6.9 Cost Estimates
- 7. Risk Assessment**
- 8. Conclusions (Capability Description; Traceability to Need Statement)**
- 9. Recommendations (if applicable)**



## **ANNEX B**

### **Materiel Development Decision (MDD) (from Enclosure 2 to DoDI 5000.02, Dec 2008)**

The Materiel Development Decision review is the formal entry point into the acquisition process and shall be mandatory for all programs. Funding for this phase shall normally be limited to satisfaction of the Materiel Solution Analysis Phase objectives.

At the Materiel Development Decision review, the Joint Staff shall present the JROC recommendations and the DoD Component shall present the ICD including: the preliminary concept of operations, a description of the needed capability, the operational risk, and the basis for determining that non-materiel approaches will not sufficiently mitigate the capability gap. The Director, Program Analysis & Evaluation (DPA&E), (or DoD Component equivalent) shall propose study guidance for the Analysis of Alternatives (AoA).

The MDA shall approve the AoA study guidance; determine the acquisition phase of entry; identify the initial review milestone; and designate the lead DoD Component(s). MDA decisions shall be documented in an Acquisition Decision Memorandum (ADM). The MDA's decision to begin Materiel Solution Analysis DOES NOT mean that a new acquisition program has been initiated.

Following approval of the study guidance, the lead DoD Component(s) shall prepare an AoA study plan to assess preliminary materiel solutions, identify key technologies, and estimate life-cycle costs. The purpose of the AoA is to assess the potential materiel solutions to satisfy the capability need documented in the approved ICD.

The ICD and the AoA study guidance shall guide the AoA and Materiel Solution Analysis Phase activity. The AoA shall focus on identification and analysis of alternatives, measures of effectiveness, cost, schedule, concepts of operations, and overall risk. The AoA shall assess the critical technology elements (CTEs) associated with each proposed materiel solution, including technology maturity, integration risk, manufacturing feasibility, and, where necessary, technology maturation and demonstration needs. To achieve the best possible system solution, emphasis shall be placed on innovation and competition. Existing commercial-off-the-shelf (COTS) functionality and solutions drawn from a diversified range of large and small businesses shall be considered.

#### **Inputs**

- ICD
- Pre-AoA Concept Development Report
- AoA Study Guidance
- CCTDs

#### **Output**

- MDD ADM

## REFERENCES

### **Air Force**

AFI 10-601, Capabilities-Based Requirements

AFI 63-101, Operations of Capabilities-Based Acquisition System

AFI 63-1201, Life Cycle Systems Engineering

AFPAM 63-128,

Air Force Space & Missiles Center (SMC) Systems Engineering Primer and Handbook

### **Joint Chiefs of Staff**

CJCSI 3170-01, Joint Capabilities Integration and Development System (JCIDS) (Revision G in final coordination, Mar 2009)

Manual for the Operation of the Joint Capabilities Integration and Development System (Feb 2009)

### **Office of the Under Secretary of Defense (Acquisition, Technology, & Logistics)**

DoDD 5000.1, Defense Acquisition System

DoDI 5000.02, Operation of the Defense Acquisition System, Dec 2008

Risk Management Guide for DoD Acquisition

Systems Engineering Guide for Systems of Systems