

Acquisition Process Model

1.0 Perform Air Force Acquisition

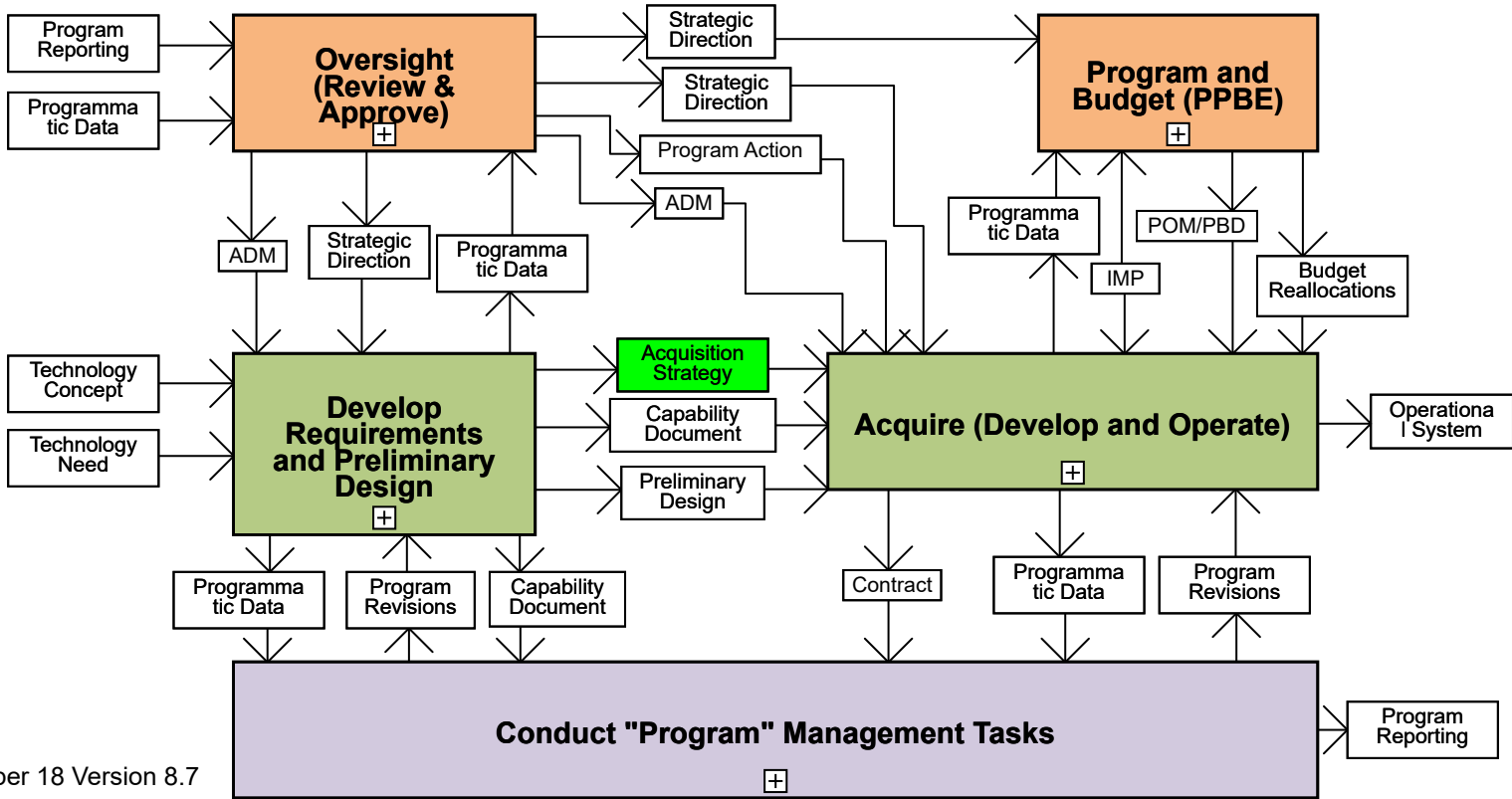

- Specialized Views**
- AFLCMC Standard Processes
 - Defense Acquisition Program Models
 - Enterprise Metrics
 - Milestone Information Requirements
 - PEO View
 - Program Reviews View
 - Rapid Acquisition Activities
 - Small Business View

Go Up 1 Level

Acquisition Process Model

1.1 Oversight (Review and Approve) - Standard Review Process

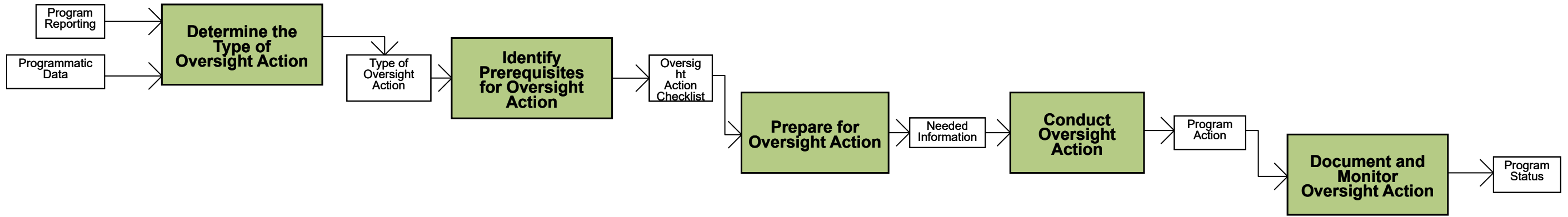

Go Up 1 Level

Acquisition Process Model

1.1 Oversight (Review and Approve)

[Click Here for the Program Reviews Integrated Flow](#)

[Standard Review Process](#)



1.1.1 Program Reviews
+

1.1.2 Portfolio Reviews
+

1.1.3 Lifecycle Reviews & Decisions
+

1.1.4 Technical Reviews
+

Note 1: from the Chief Process Officer: The Under Secretary of Defense for AT&L has provided four key enduring acquisition principles. The first of these principles is "Think". Program managers should tailor the program according to the specific needs of that program. The rote checking the blocks in a checklist or simply following each and every step of a process is the antithesis of Mr Kendall's challenge to Program Managers. Use this Model as a model. If your program's situation warrants a waiver from the checklist or process, seek that waiver from your milestone decision authority.

Note 2: The purpose of program tailoring is to streamline the acquisition program to the maximum extent possible, consistent with risk, to provide new systems to operational commanders as fast as possible. DoDI 5000.02, Section 5.a.2; AFPAM 63-128, Section 14.1.

FWD →

Go Up 1 Level

Acquisition Process Model

1.1.1 Program Reviews

PEO View

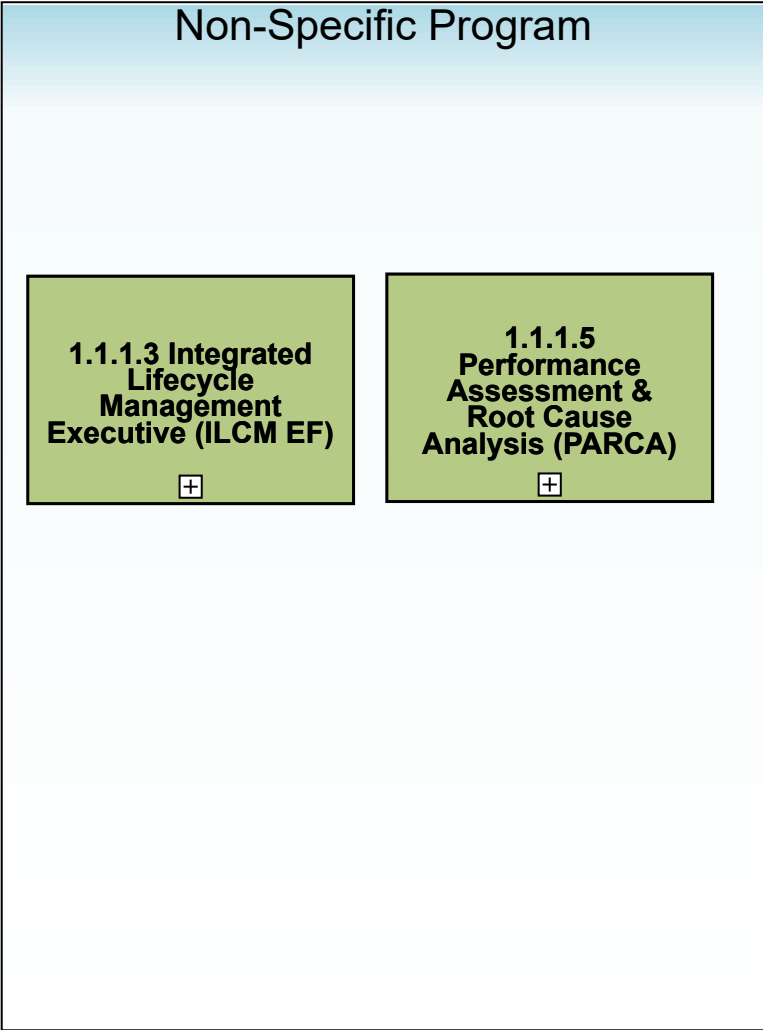
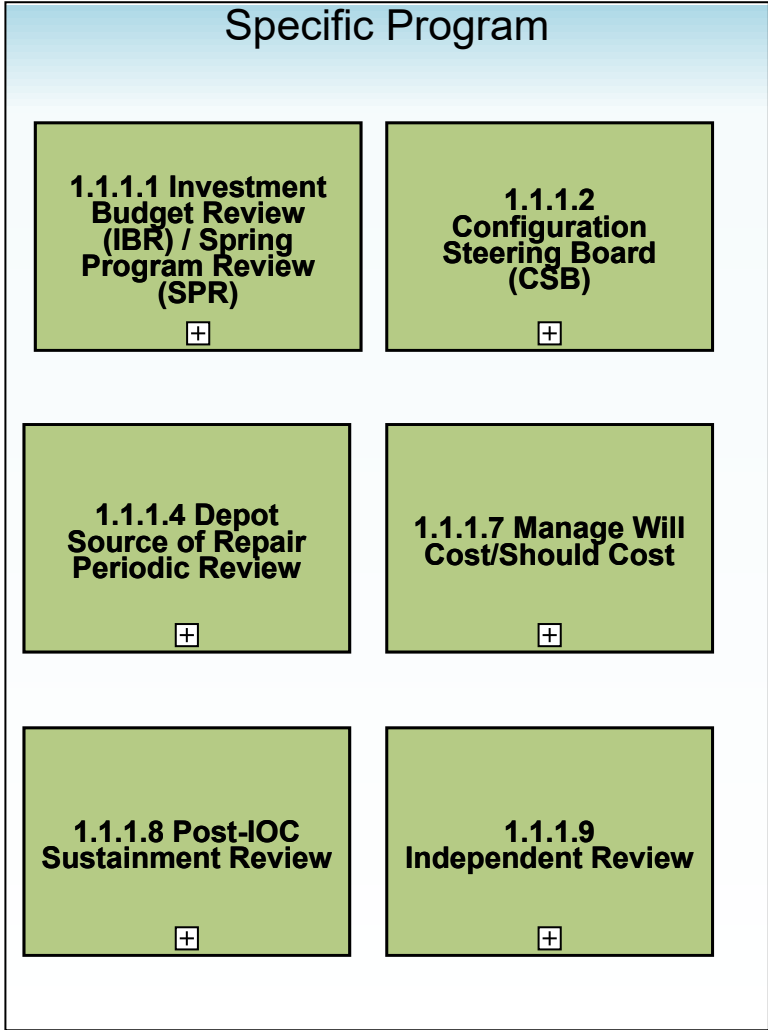

FWD

Go Up 1 Level

Acquisition Process Model

1.1.1.1 IBR-SPR

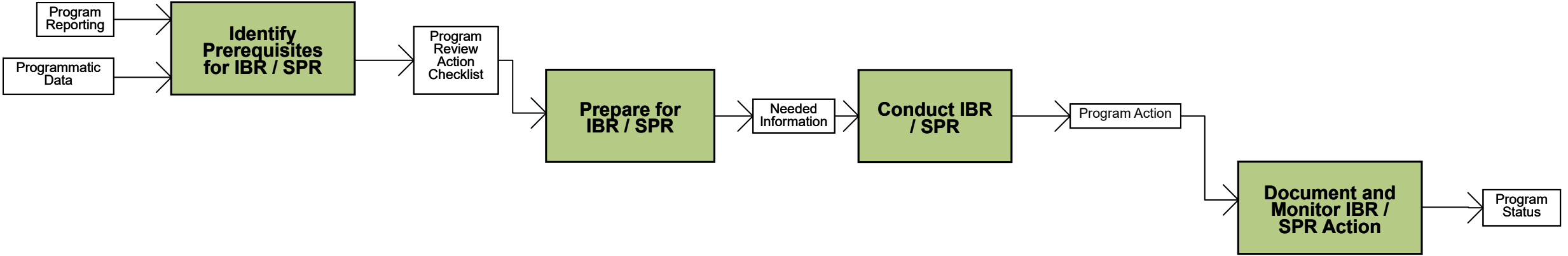

FWD

Go Up 1 Level

Acquisition Process Model

1.1.1.1.5 Conduct Spring Program Review

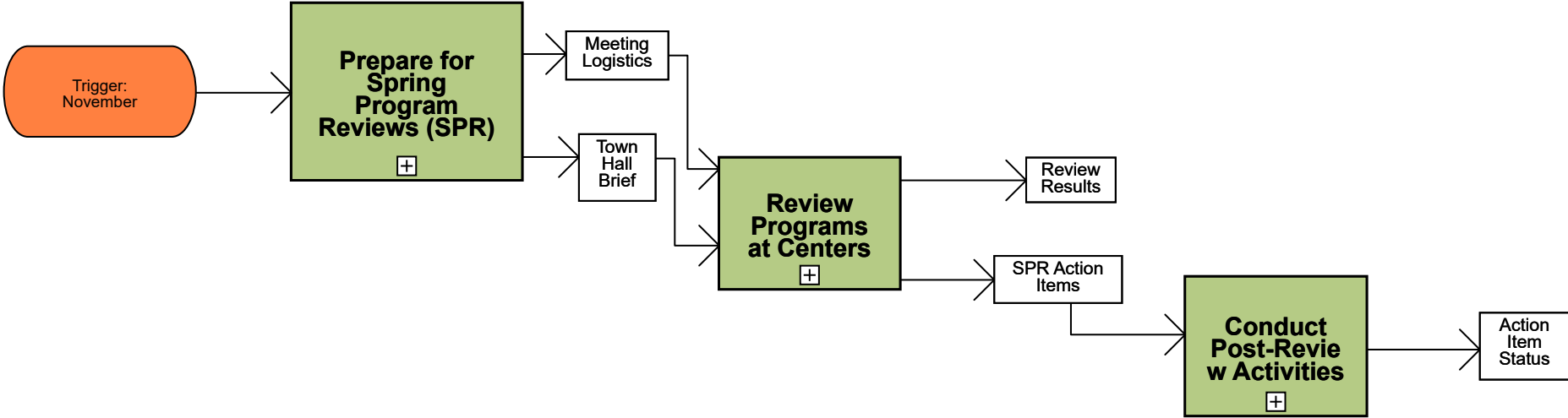

Go Up 1 Level

Acquisition Process Model

1.1.1.1.5.1 Prepare for Spring Program Reviews (SPR)

AFLCMC
Standard
Processes

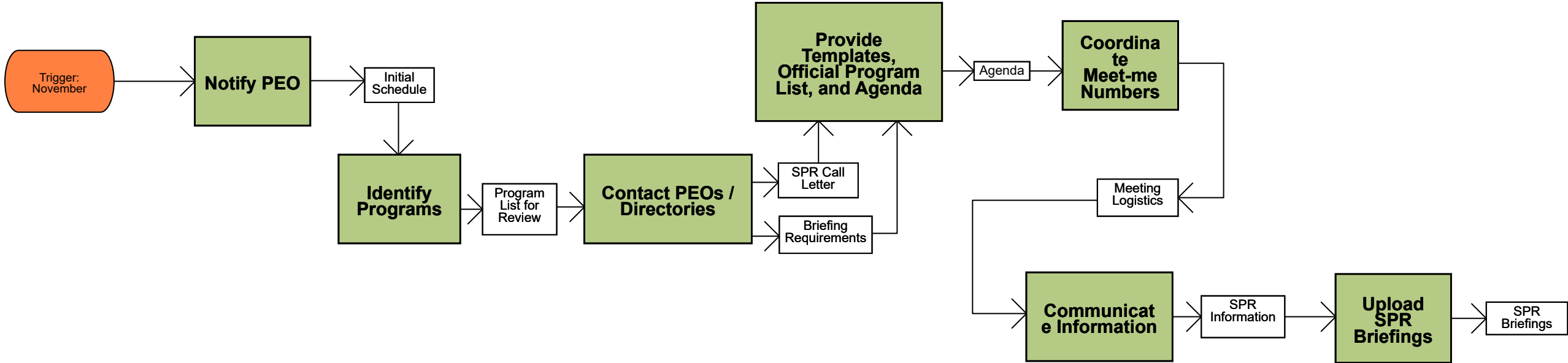

FWD

Go Up 1 Level

Acquisition Process Model

1.1.1.1.5.2 Review Programs at Centers

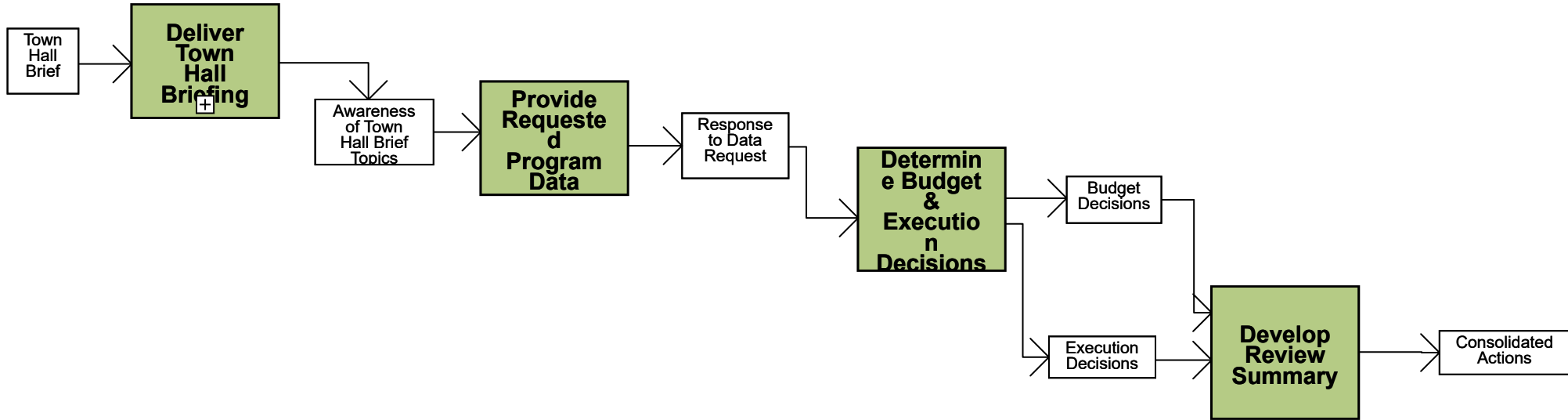

← BACK

FWD →



Acquisition Process Model

1.1.1.1.5.2.1 Deliver Town Hall Brief

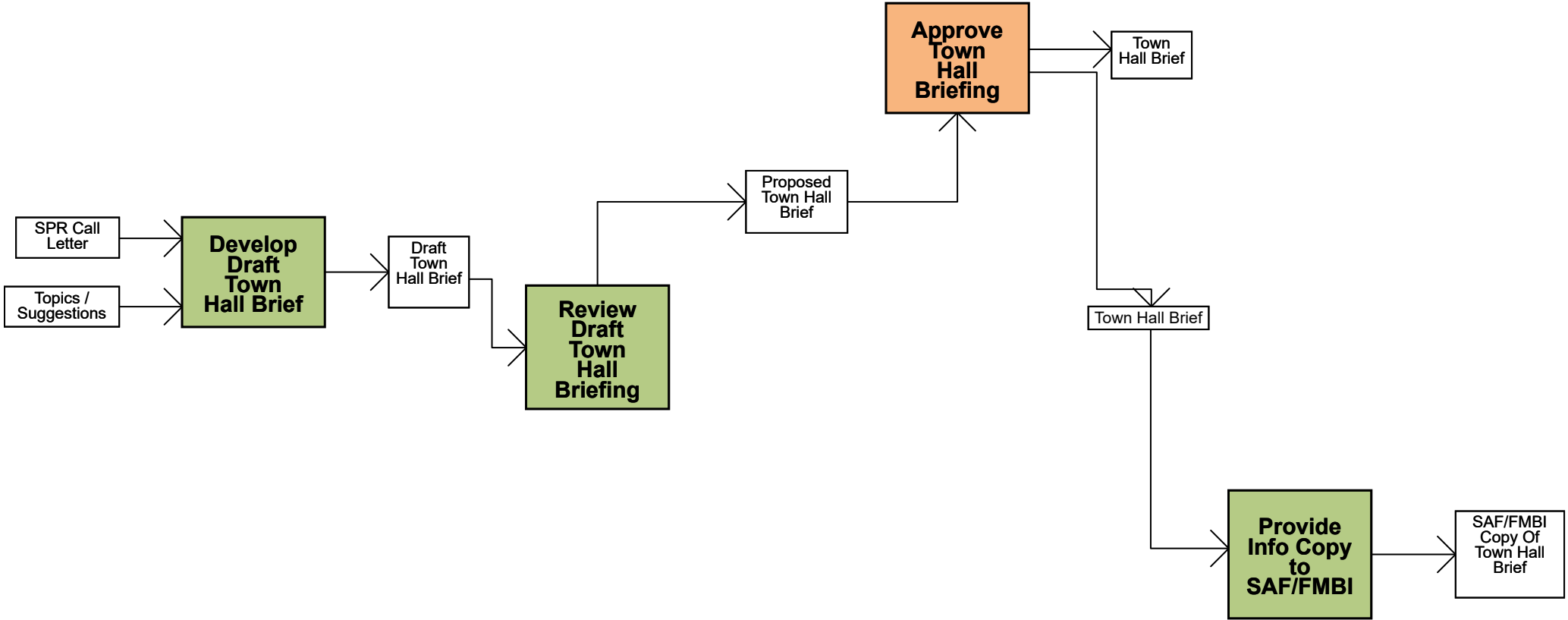

Go Up 1 Level

Acquisition Process Model

1.1.1.1.5.3 Conduct Post-Review Activities

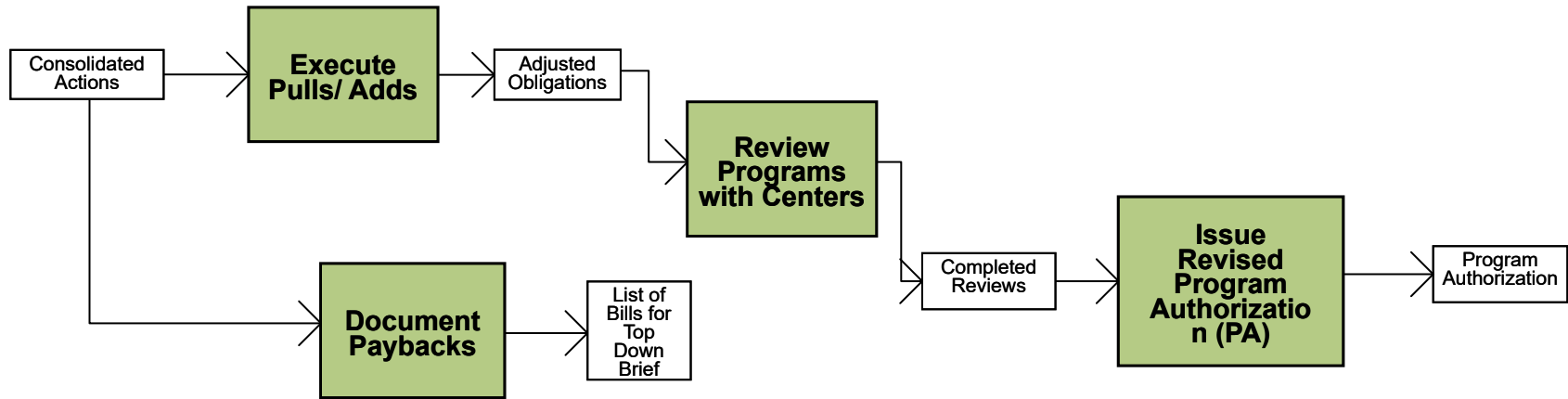

← BACK

Go Up 1 Level

Acquisition Process Model

1.1.1.2 Configuration Steering Board (CSB)

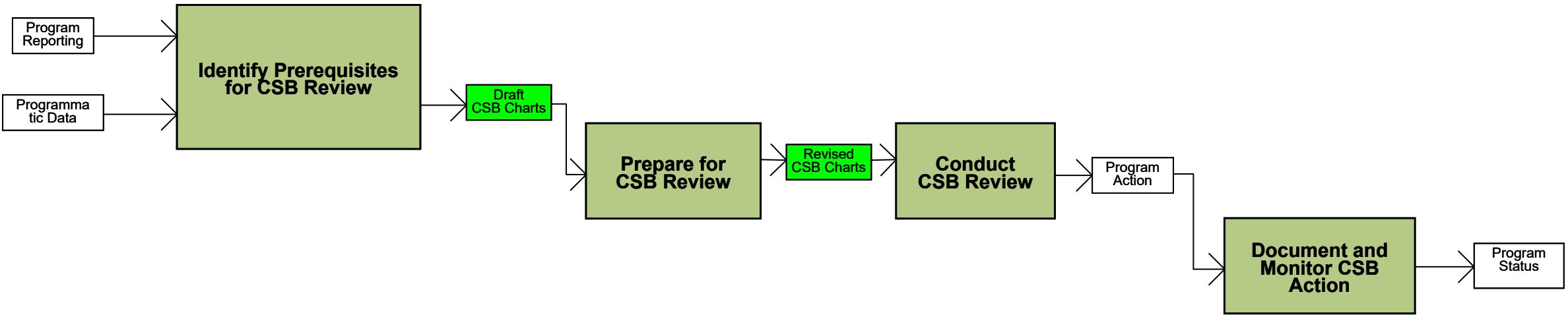
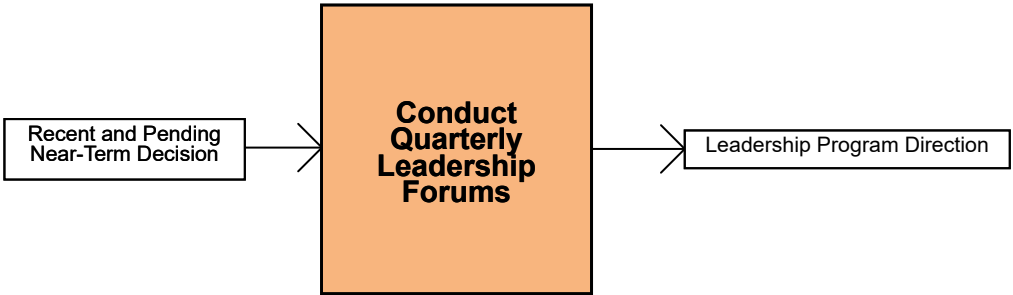

As stated in Section 825 of Public Law 115-91 and reinforced in the attached memo, a CSB is not required if the Service Acquisition Executive determines in writing that a program had no requirement changes in the prior year. Also, regulatory CSBs will be treated similarly. CSBs shall only be conducted with SAF/AQ when requested by the PEO where changes to requirements have the potential to improve cost and schedule

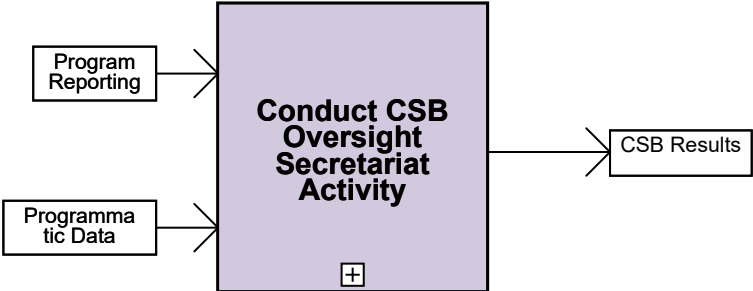

Go Up 1 Level

Acquisition Process Model

1.1.1.2.5 Conduct CSB Oversight Secretariat Activity

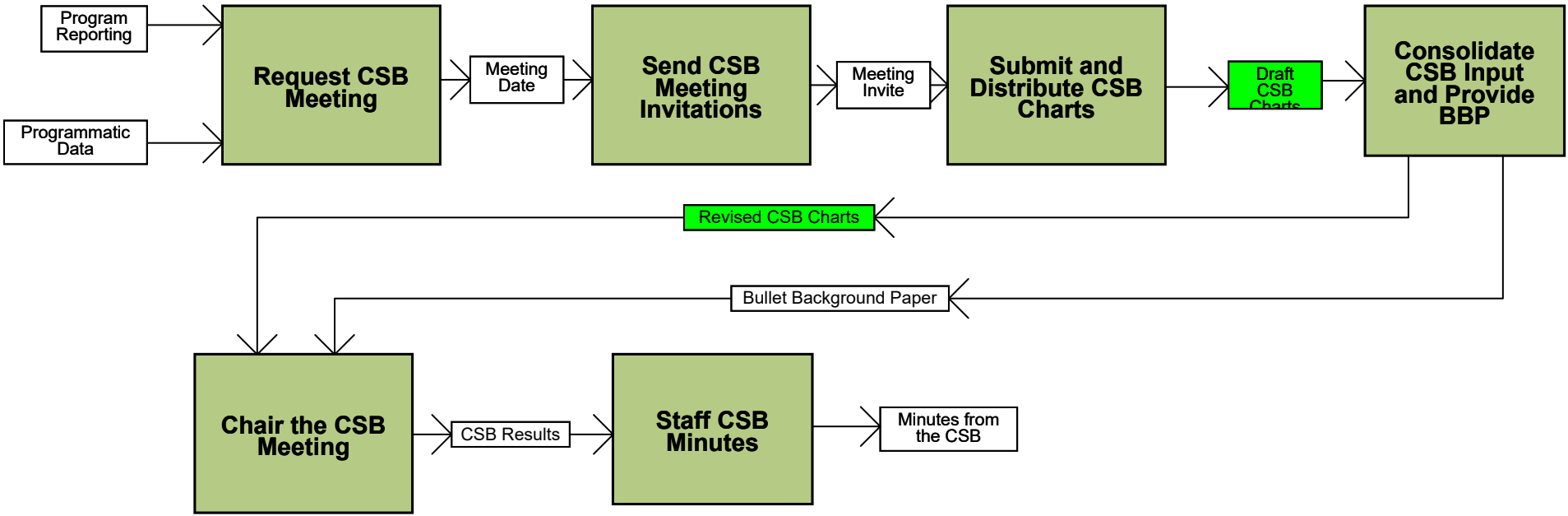

Go Up 1 Level

Acquisition Process Model

1.1.1.3 ILCM EF

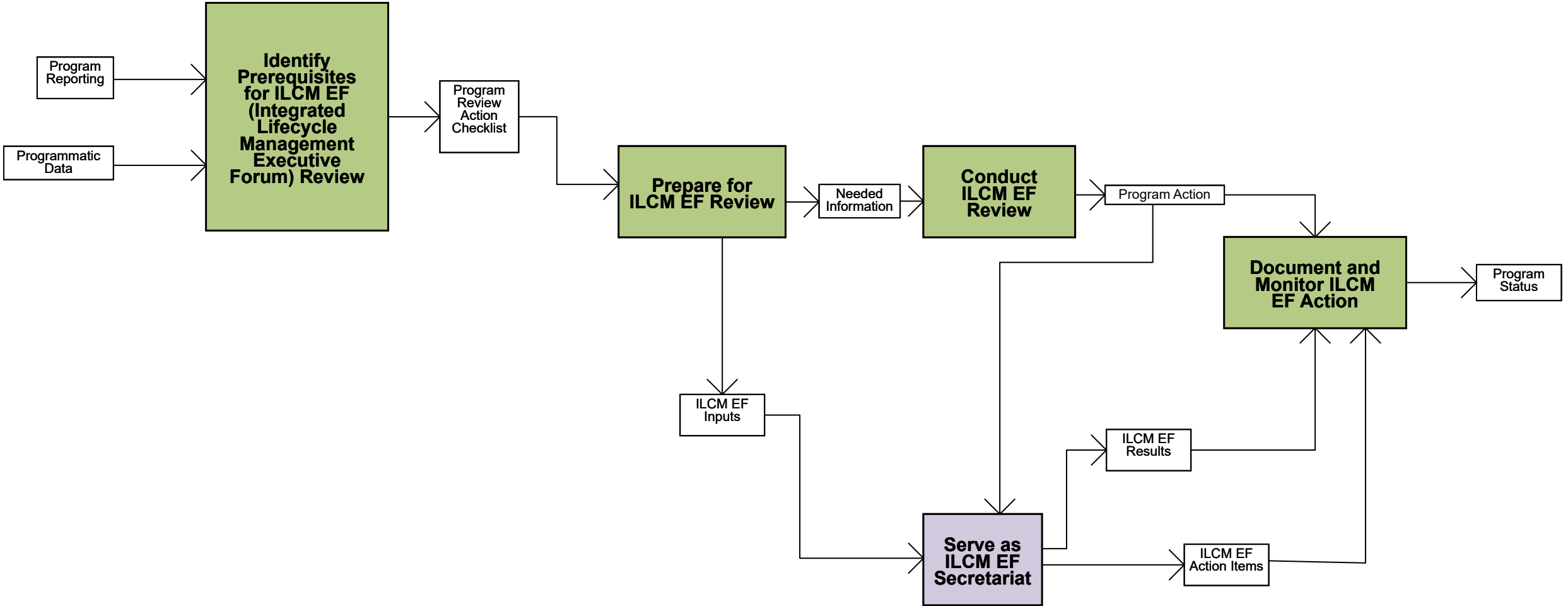

← BACK

FWD →

Go Up 1 Level

Acquisition Process Model

1.1.1.4 Depot Source of Repair Periodic Review

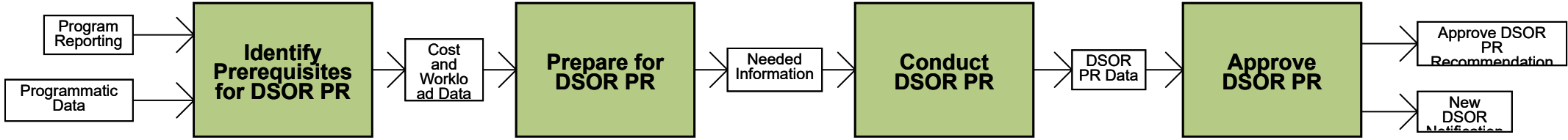

← BACK

FWD →

Acquisition Process Model

1.1.1.5 PARCA

Go Up 1 Level

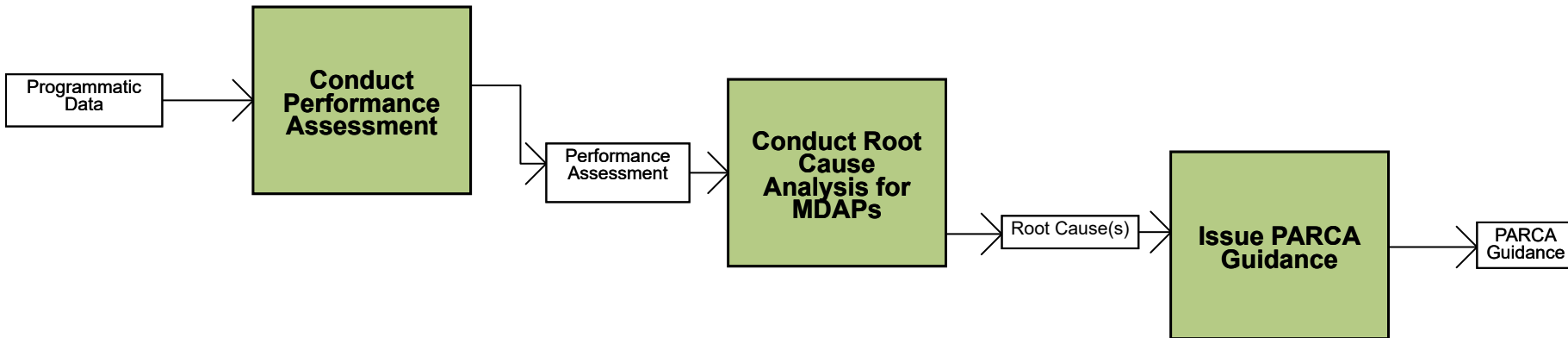

Note: This includes reviews conducted after Nunn-McCurdy breaches.

BACK FWD

Go Up 1 Level

Acquisition Process Model

1.1.1.8 Post IOC Sustainment Review

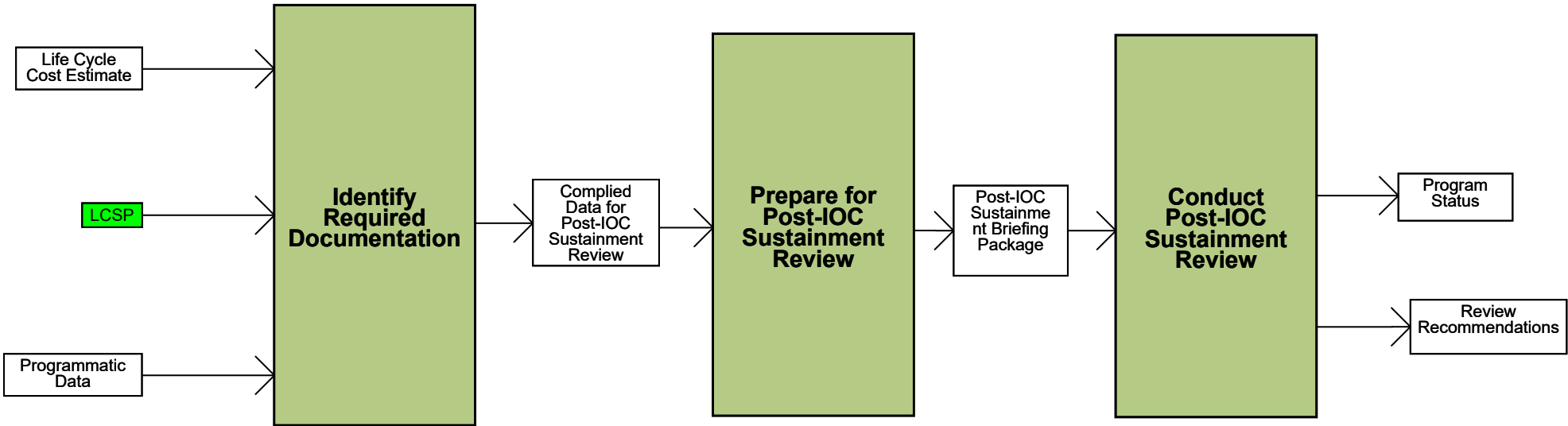

← BACK

FWD →

Go Up 1 Level

Acquisition Process Model

1.1.1.9 Independent Reviews

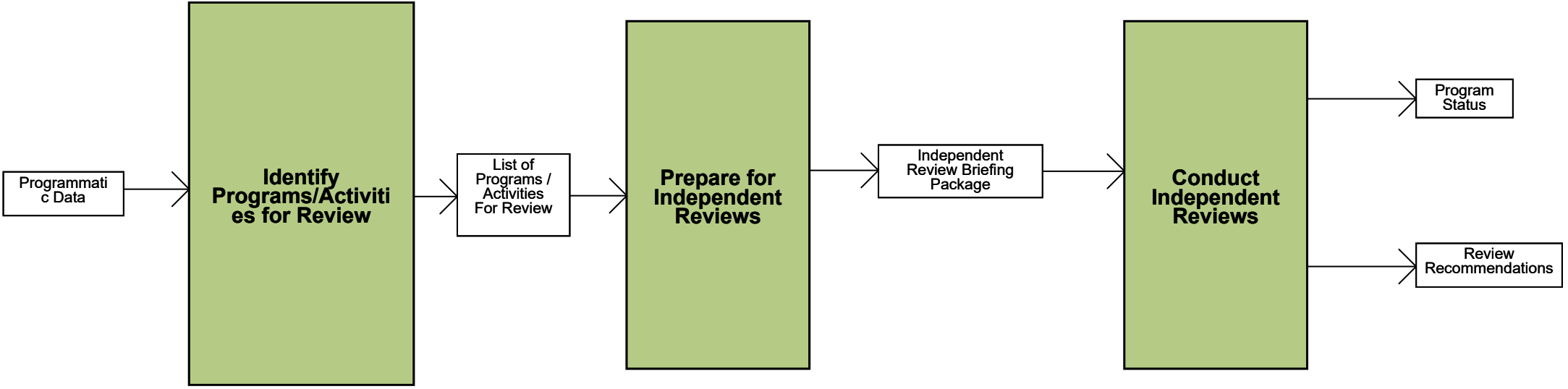

← BACK

Go Up 1 Level

Acquisition Process Model

1.1.2 Portfolio Reviews

PEO View

1.1.2.1 PEO/SAE

1.1.2.2 Budget Execution Review

1.1.2.3 ASR

1.1.2.5 Capability Portfolio Review

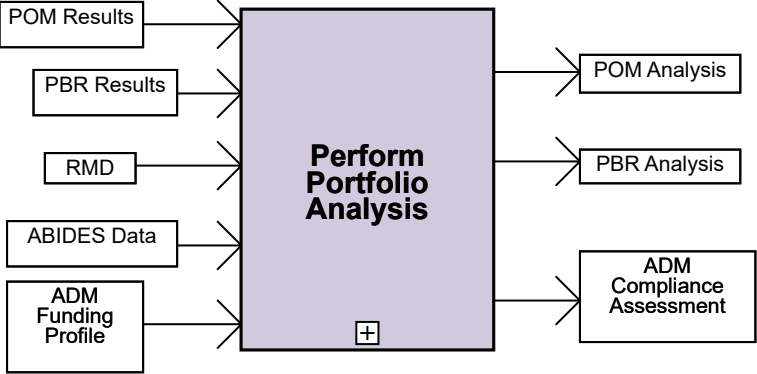
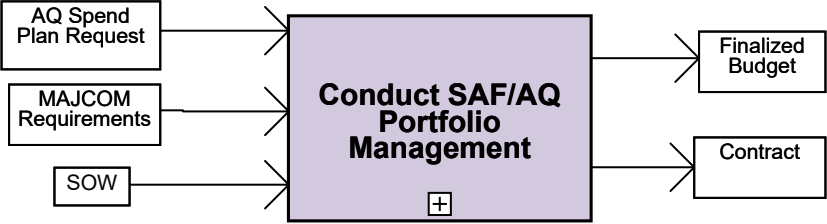

BACK

FWD

Go Up 1 Level

Acquisition Process Model

1.1.2.1 PEO SAE Reviews

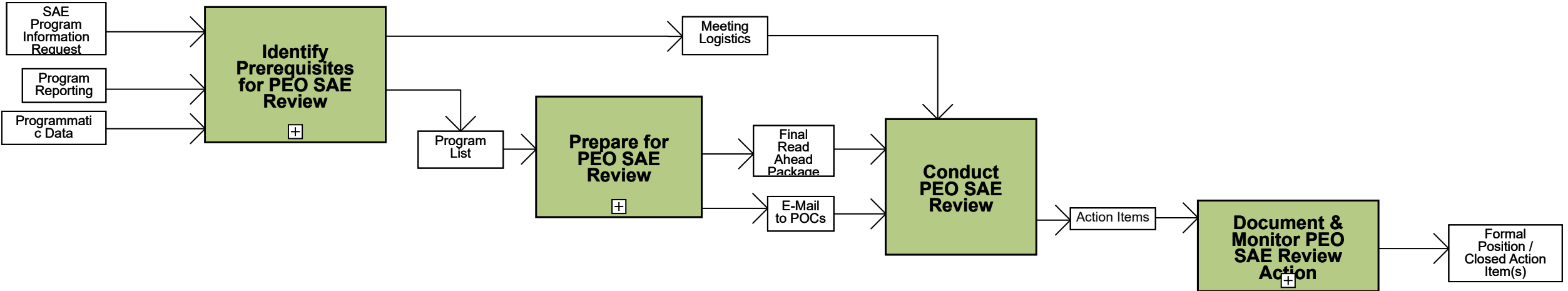

FWD

Go Up 1 Level

Acquisition Process Model

1.1.2.1.1 Prerequisites for PEO SAE Review

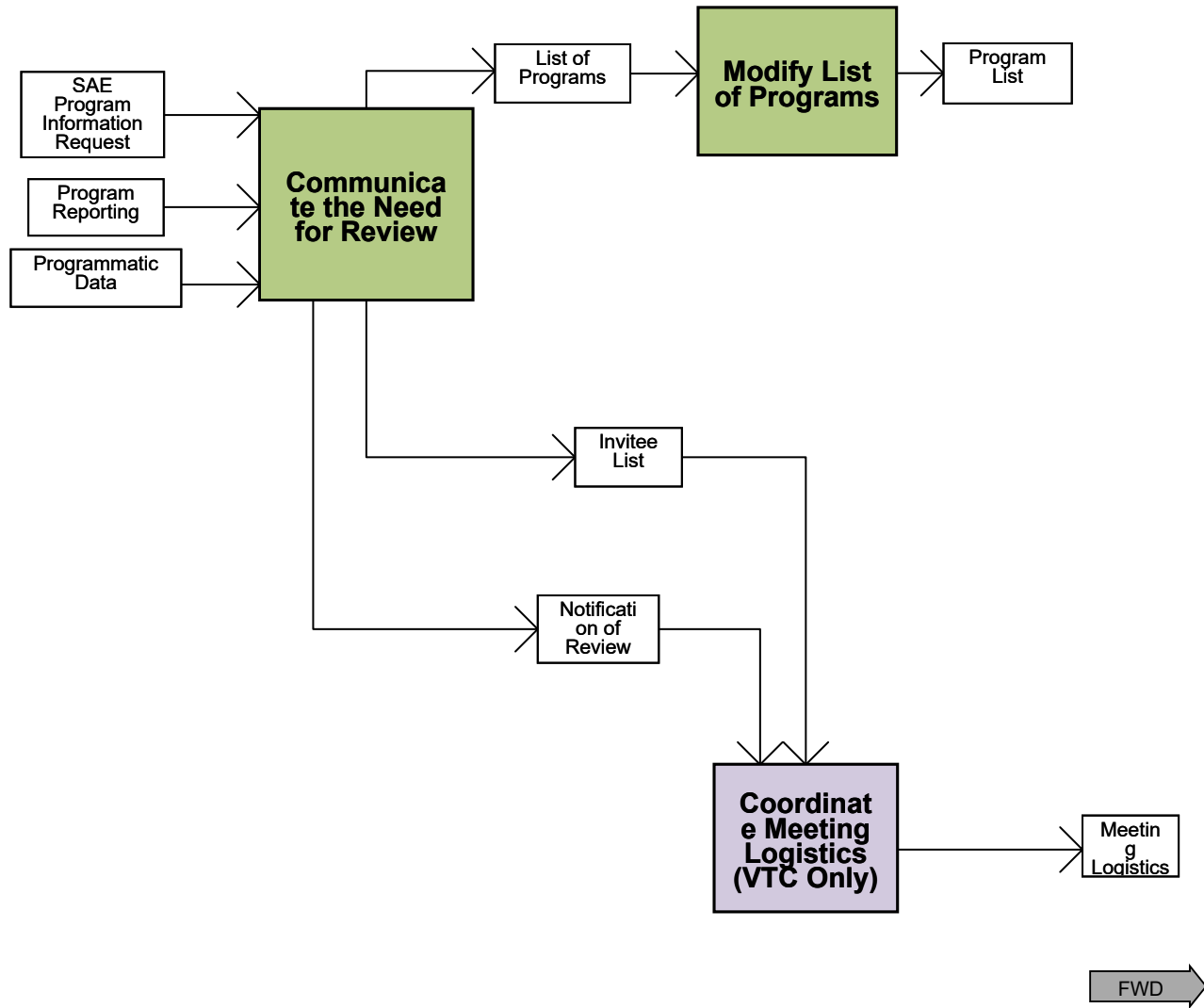

Go Up 1 Level

Acquisition Process Model

1.1.2.1.2 Prepare for PEO SAE Review

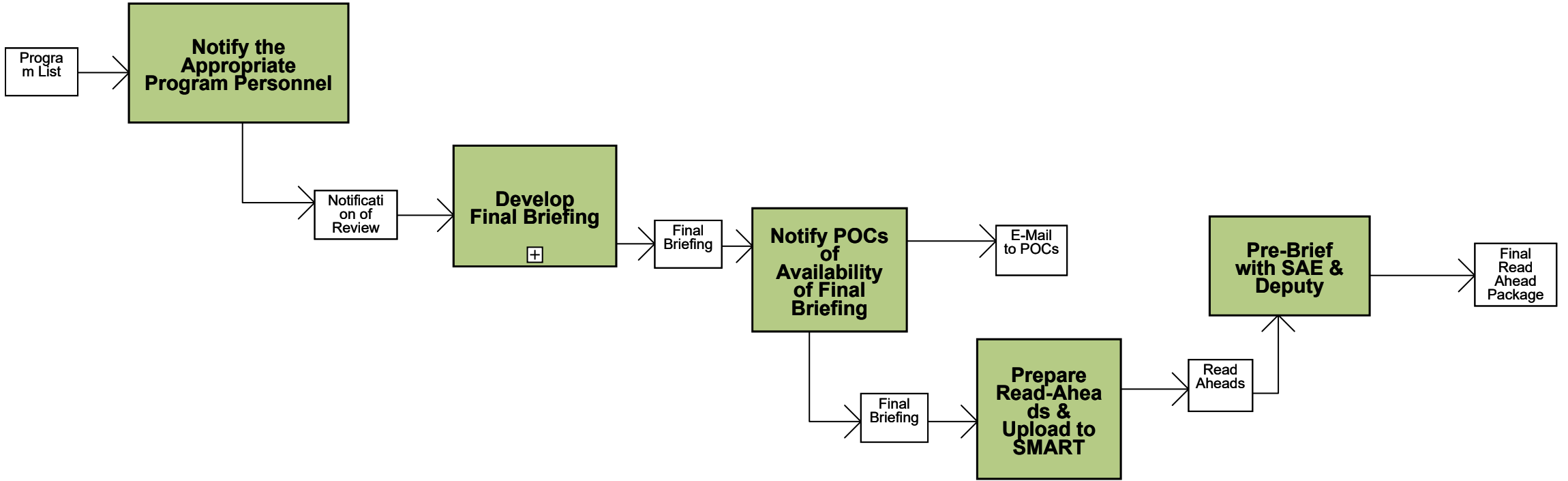

← BACK

FWD →

Go Up 1 Level

Acquisition Process Model

1.1.2.1.2.2 Develop Final Briefing

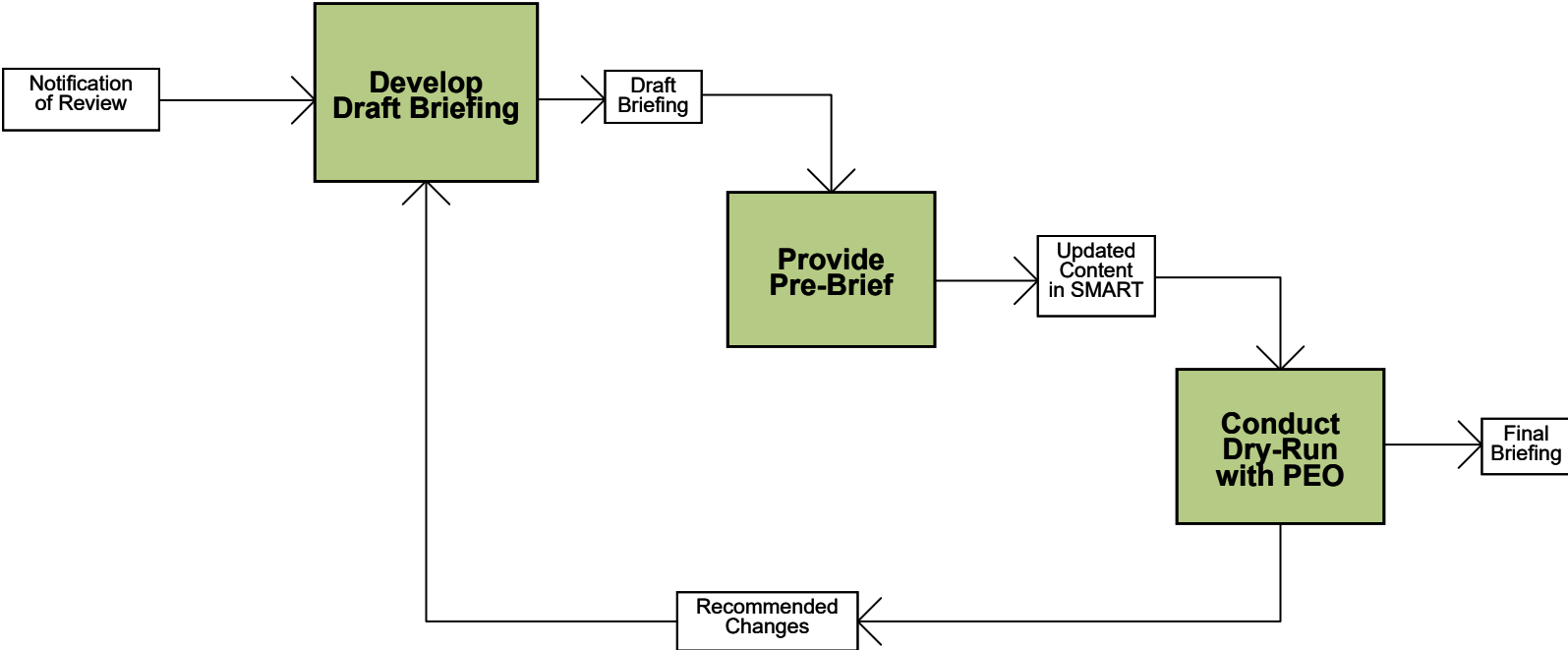

Go Up 1 Level

Acquisition Process Model

1.1.2.1.4 Document & Monitor PEO SAE Review Action

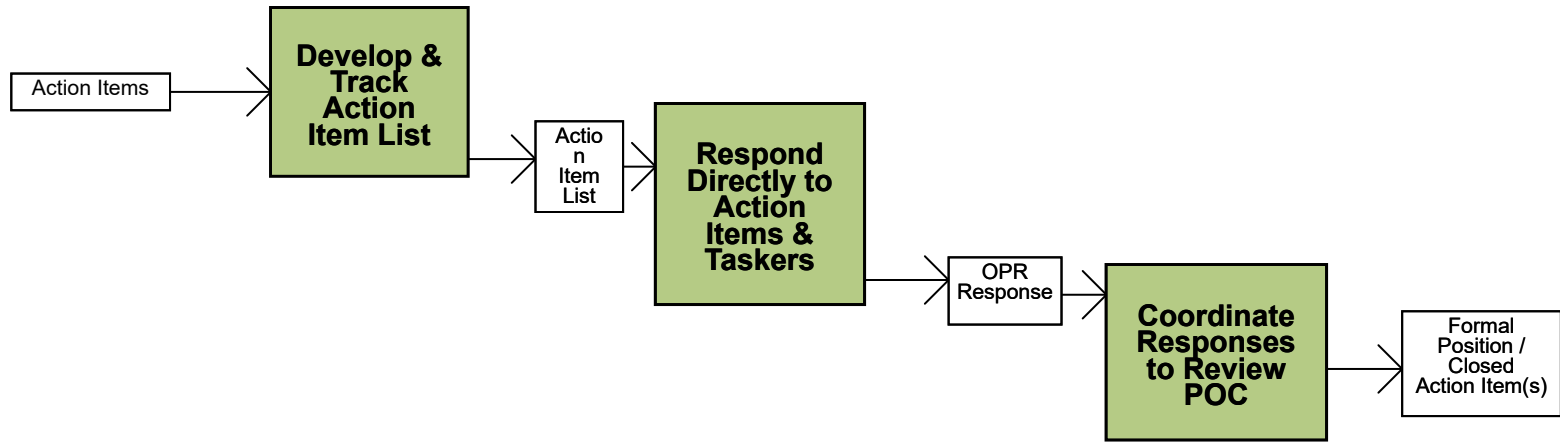

← BACK

Go Up 1 Level

Acquisition Process Model

1.1.2.2 Budget Execution Review

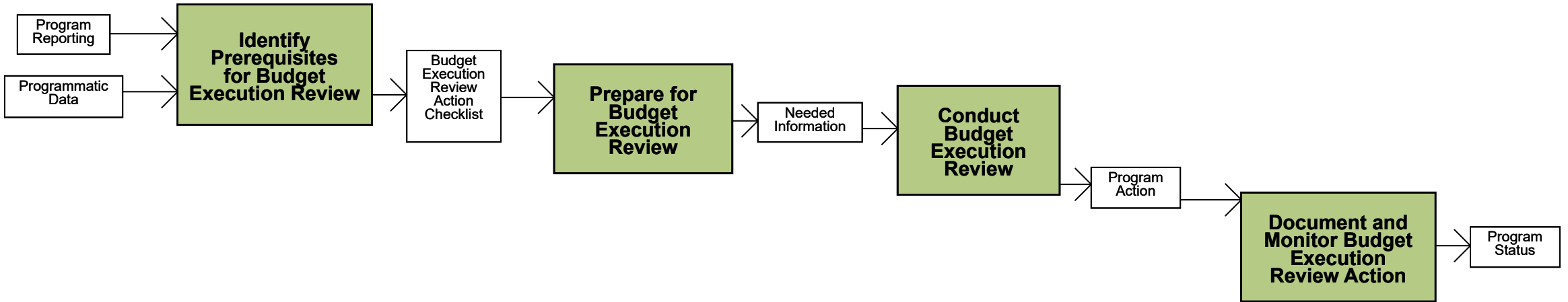

← BACK

FWD →

Go Up 1 Level

Acquisition Process Model

1.1.2.3 Acquisition and Sustainment Review (ASR)

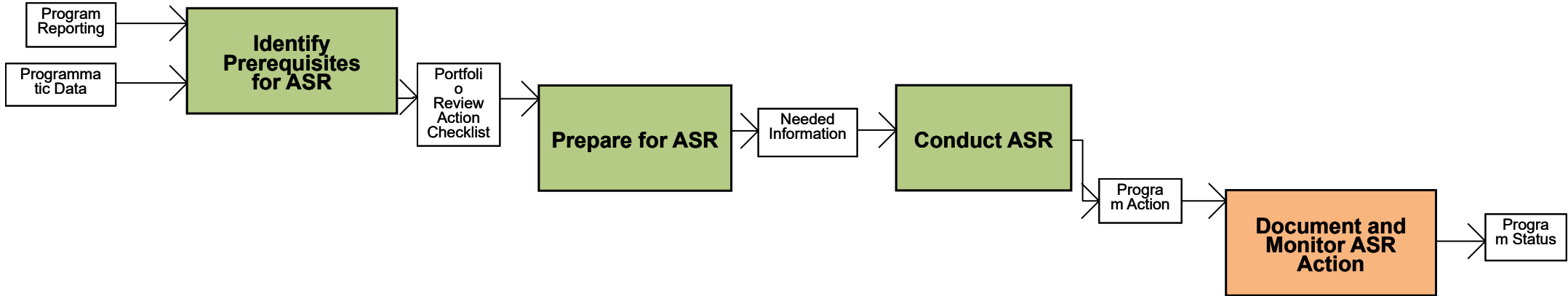

← BACK

FWD →

Go Up 1 Level

Acquisition Process Model

1.1.2.5 Capability Portfolio Review

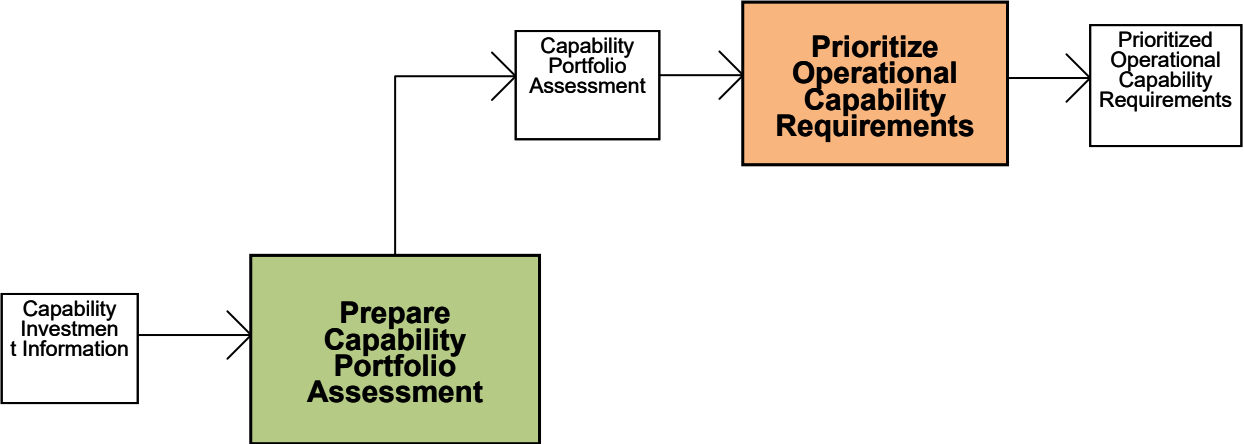

← BACK

FWD →

Go Up 1 Level

Acquisition Process Model

1.1.2.6 Conduct SAF/AQ Portfolio Management

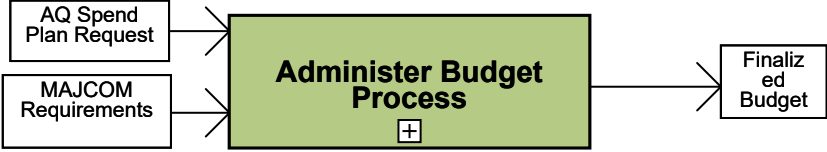

BACK

FWD

Go Up 1 Level

Acquisition Process Model

1.1.2.6.1 Administer Budget Process

Trigger:
Request AQ
Spend Plan

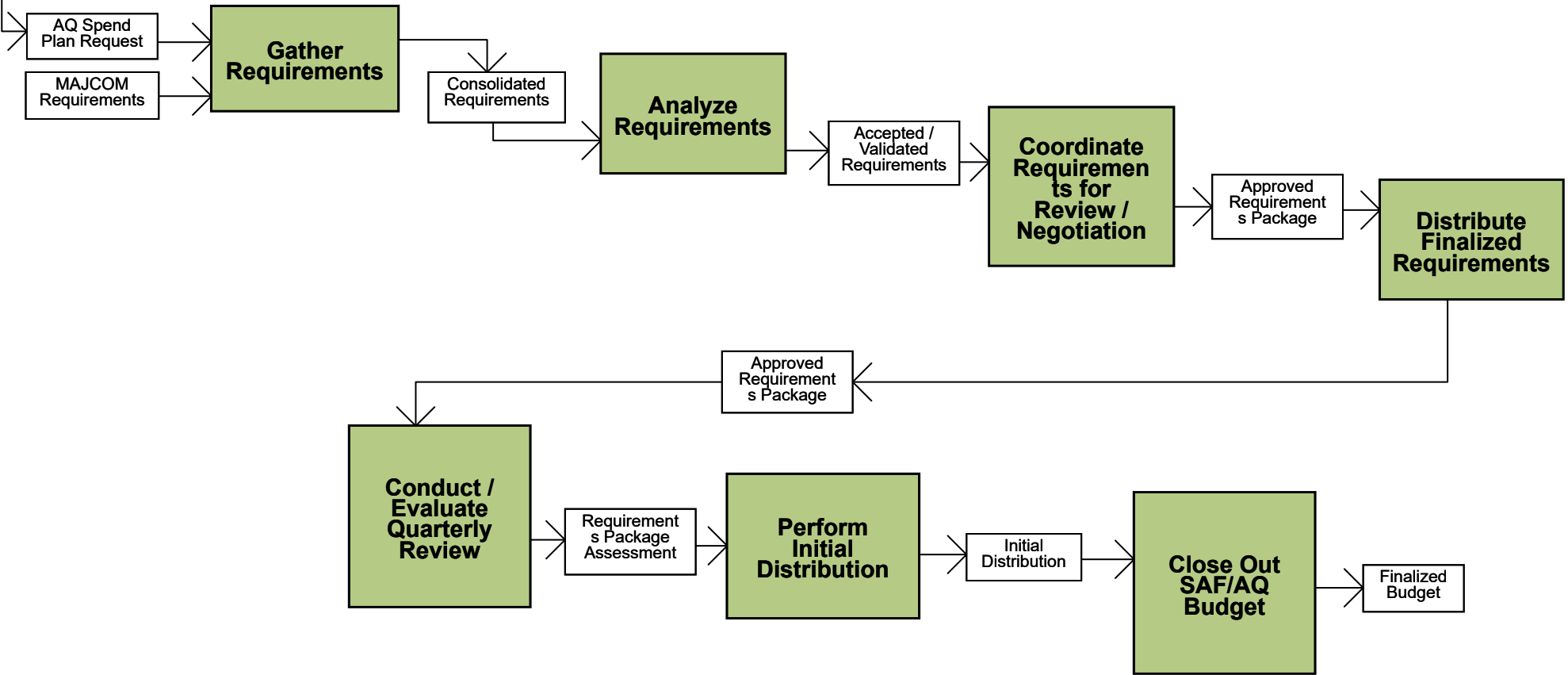

FWD

Acquisition Process Model

1.1.2.6.2 Conduct SAF AQ Source Selections

Go Up 1 Level

Tripper: PM Submits SOW

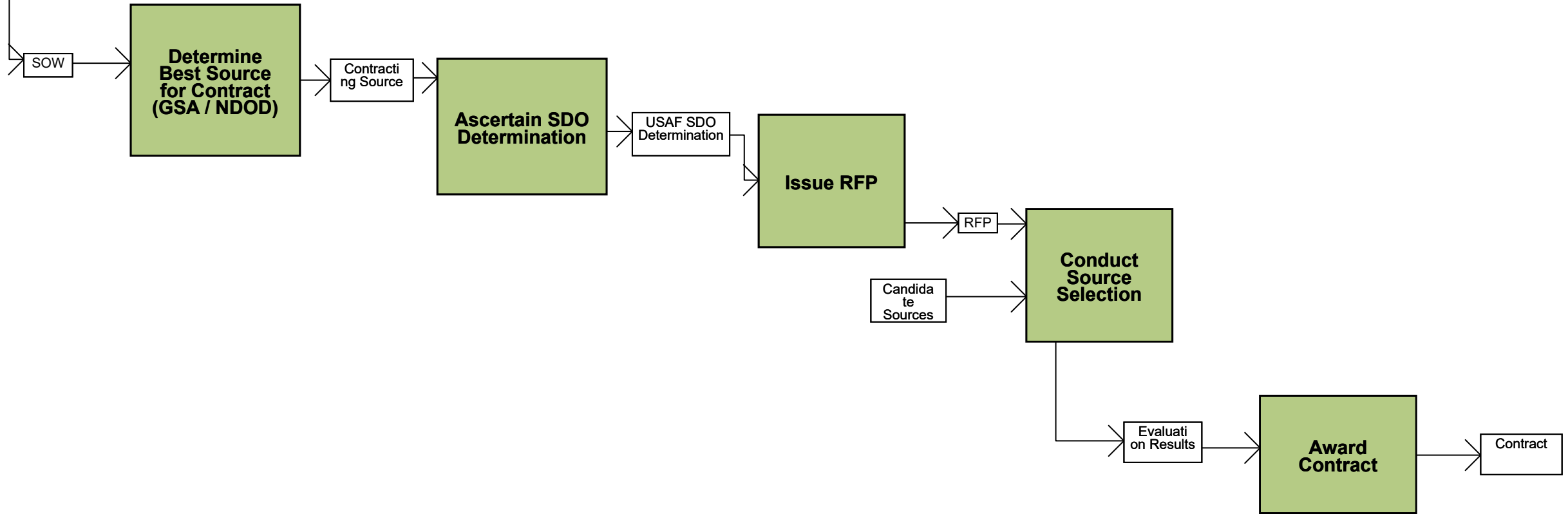

← BACK

Go Up 1 Level

Acquisition Process Model

1.1.2.7 Perform Portfolio Analysis

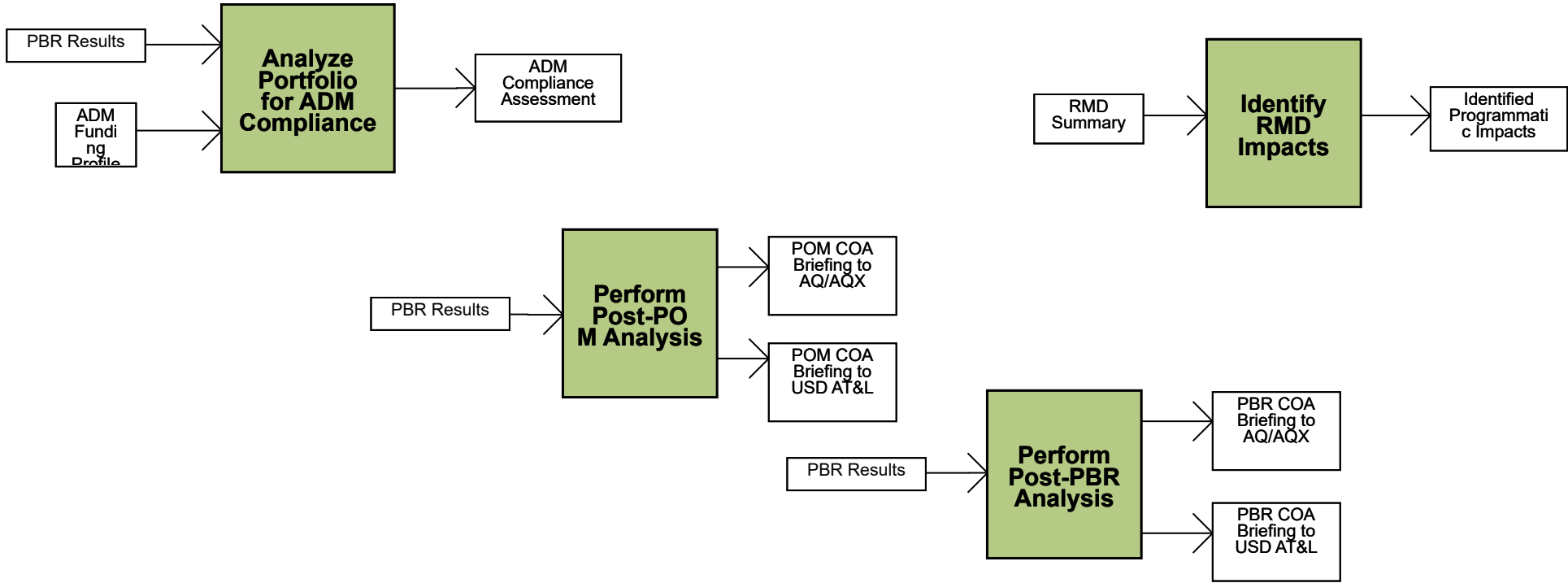

← BACK

Acquisition Process Model

1.1.3 Lifecycle Reviews & Decisions

Go Up 1 Level

1.1.3.7 MDD The MDD review is the formal entry into the acquisition process substantiating the need for a materiel solution based on a validated capability gap.

1.1.3.8 FRP Decision Review Continuation into full-rate production results from a successful Full-Rate Production (or Full Deployment) Decision Review by the MDA. The decision to proceed into Full-Rate Production will be documented in an ADM. This effort delivers the fully funded quantity of systems and supporting materiel and services for the program or increment to the users.

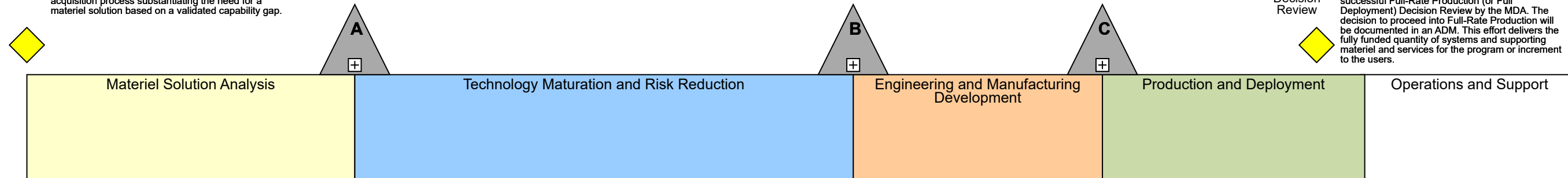

1.1.3.2 AFROC

1.1.3.3 ASP

1.1.3.9 MS A AFRB

1.1.3.1 DAB

1.1.3.2 AFROC

1.1.3.3 ASP

1.1.3.17 Dev. RFP AFRB

1.1.3.1 4 Dev. RFP Release

1.1.3.16 DBC

1.1.3.10 MS B AFRB

1.1.3.1 DAB

1.1.3.2 AFROC

1.1.3.3 ASP

1.1.3.16 DBC

1.1.3.11 MS C AFRB

1.1.3.1 DAB

1.1.3.3 ASP

1.1.3.12 FRP AFRB

1.1.3.1 DAB

1.1.3.13 Terminate Acquisition Effort

Note: Per the Chief Process Officer: The Dev RFP Release ASP is combined with an AFRB. (AFI 63-101/20-101, Section 4.8.1)

← BACK

FWD →

Go Up 1 Level

Acquisition Process Model

1.1.3.1 Defense Acquisition Board (DAB)

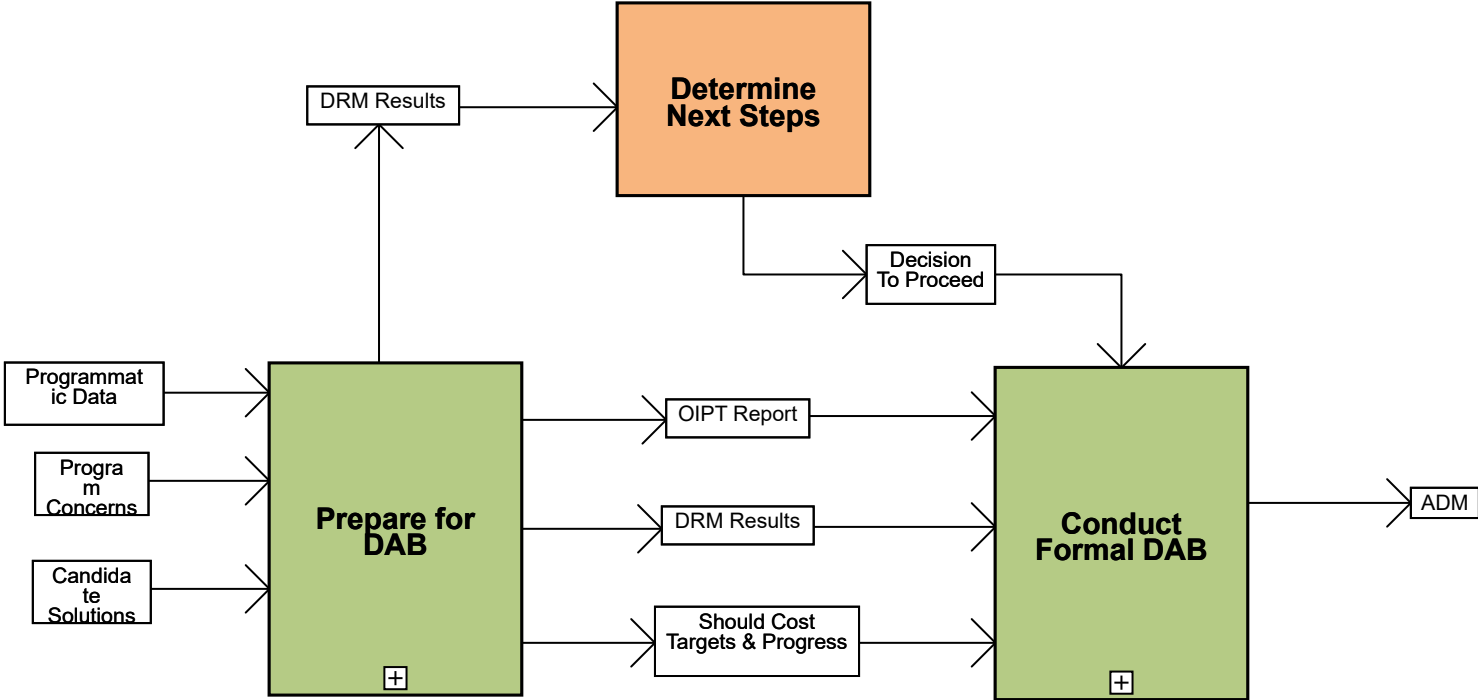

Go Up 1 Level

Acquisition Process Model

1.1.3.1.1 DAB (Prepare for DAB)

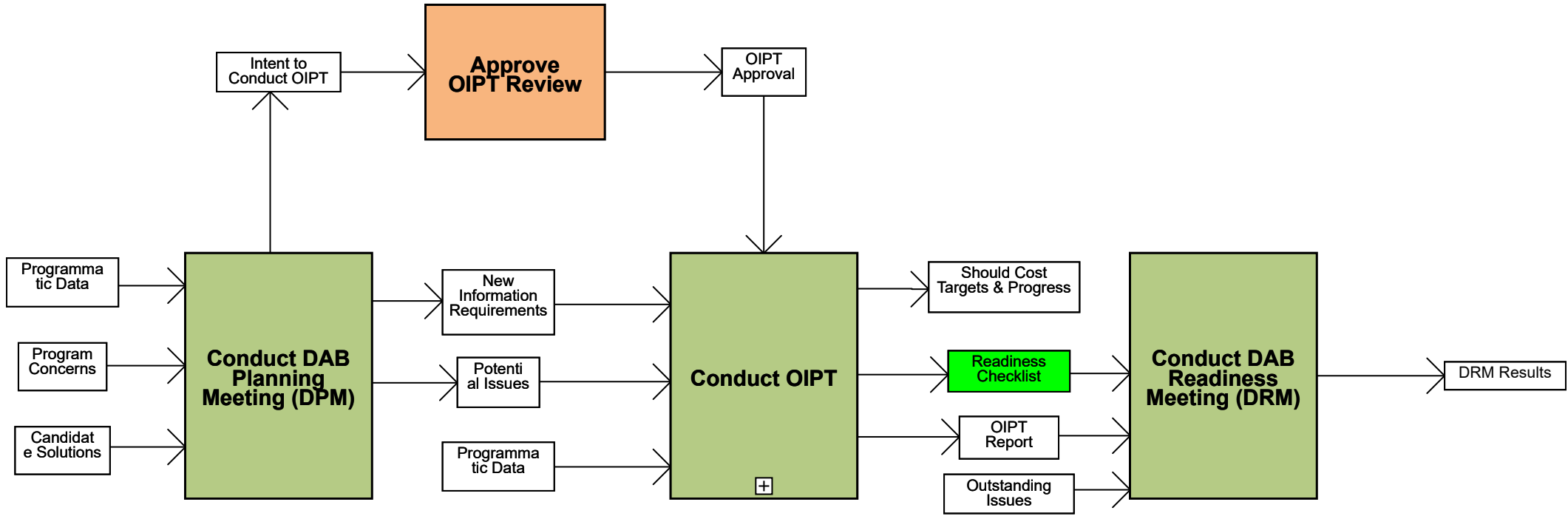

Note: As stated in Section 5.a.4.g of DoDI 5000.02, DAB review preparation will be streamlined and efficient. Staff members will be provided with the data needed to support the review in accordance with scheduled submission dates established throughout this instruction. They will work to minimize the overhead burden placed on the DoD Components, PEOs, program managers, and their staffs. Staff reviews will focus on the substance of the program's content: affordability, requirements reasonableness, technical risk reduction, contracting strategy, schedule realism, testing provisions, funding adequacy, and future decision criteria. Reviewers will inform the DAB chairperson and MDA, the OIPT leader, and the Military Service concerned of potential DAB issues. The MDA will prioritize key cost, schedule and performance issues to be addressed at the DAB. The Military Service concerned will address administrative or advisory comments. Similar procedures will be used for DoD Component-level reviews.

FWD

Go Up 1 Level

Acquisition Process Model

1.1.3.1.1.3 OIPT

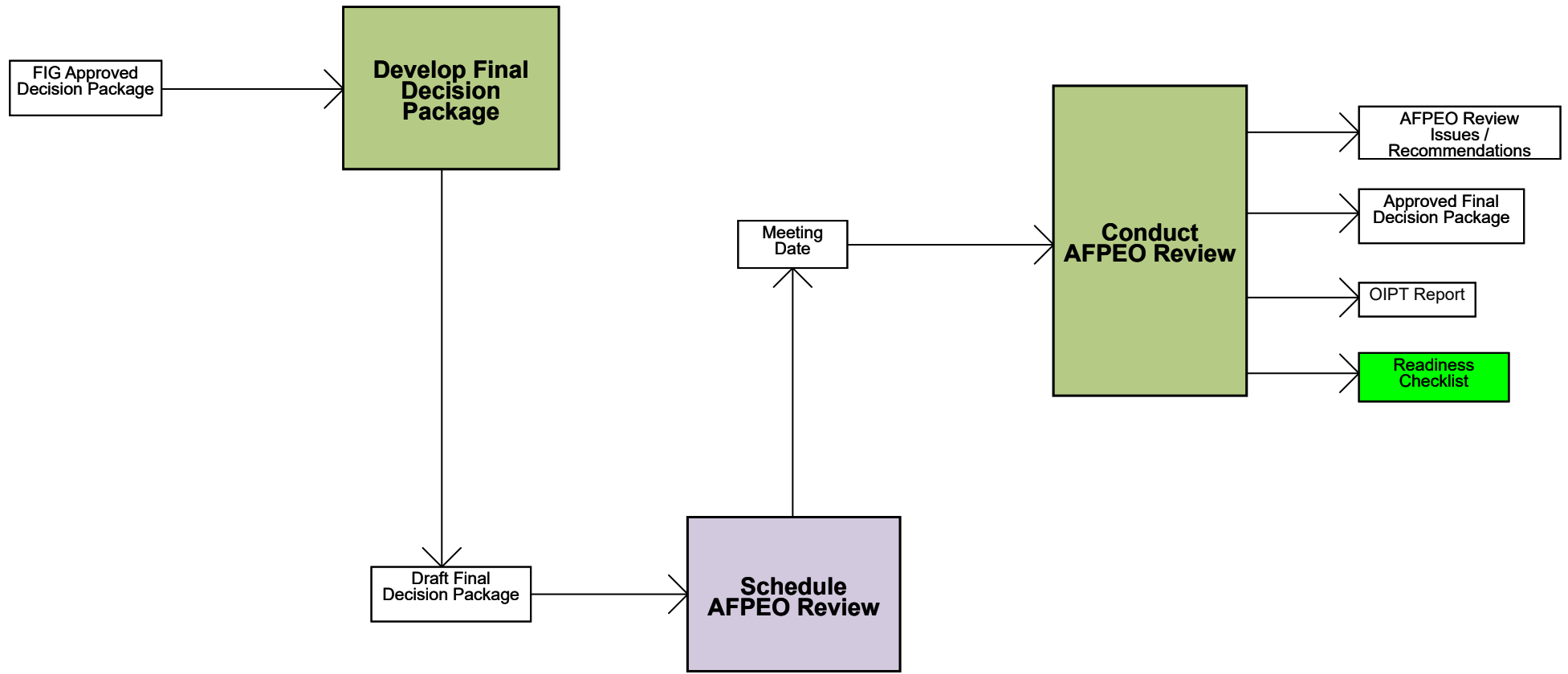

Note: The above process is also performed in preparation for the Milestone A AFRB, the Milestone B AFRB, the Milestone C AFRB, and the Full Rate Production AFRB. The only difference in these processes are the specific inputs and outputs at the various decision points.



Acquisition Process Model

1.1.3.1.3 DAB (Conduct DAB)

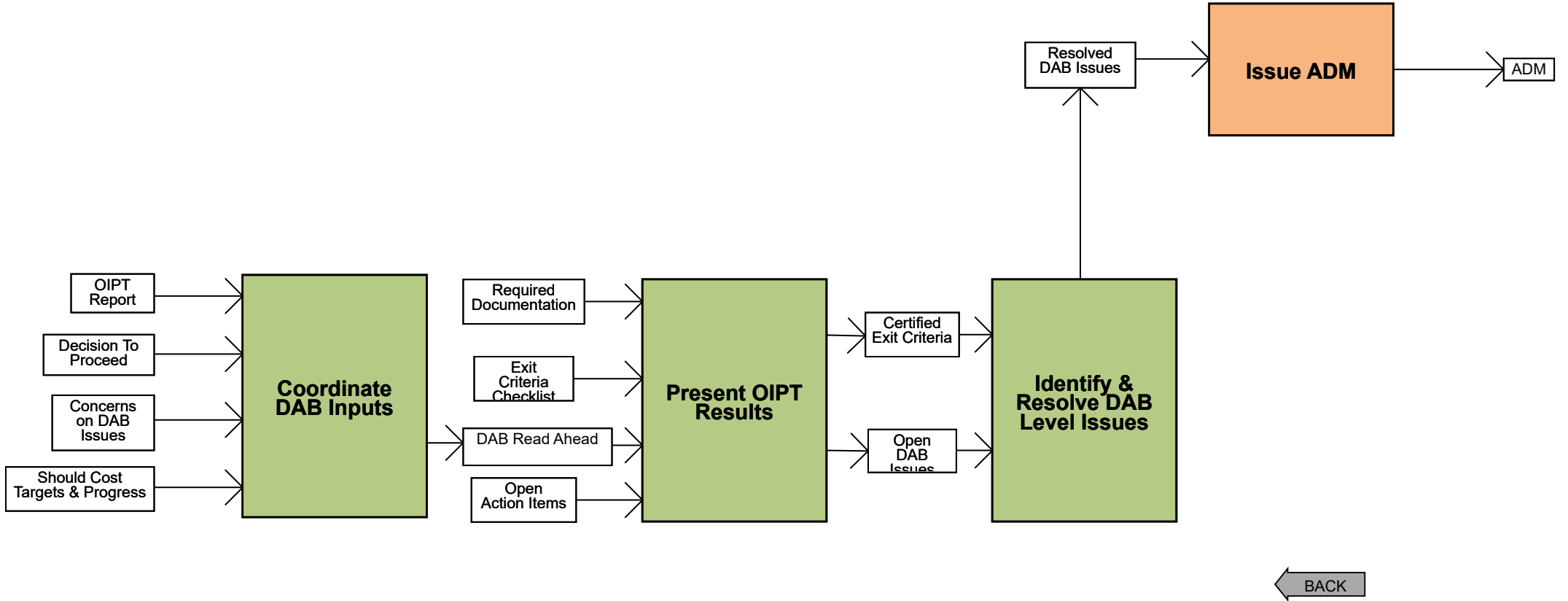

Go Up 1 Level

Acquisition Process Model

1.1.3.10 Milestone B AFRB

Milestone B Information Requirements

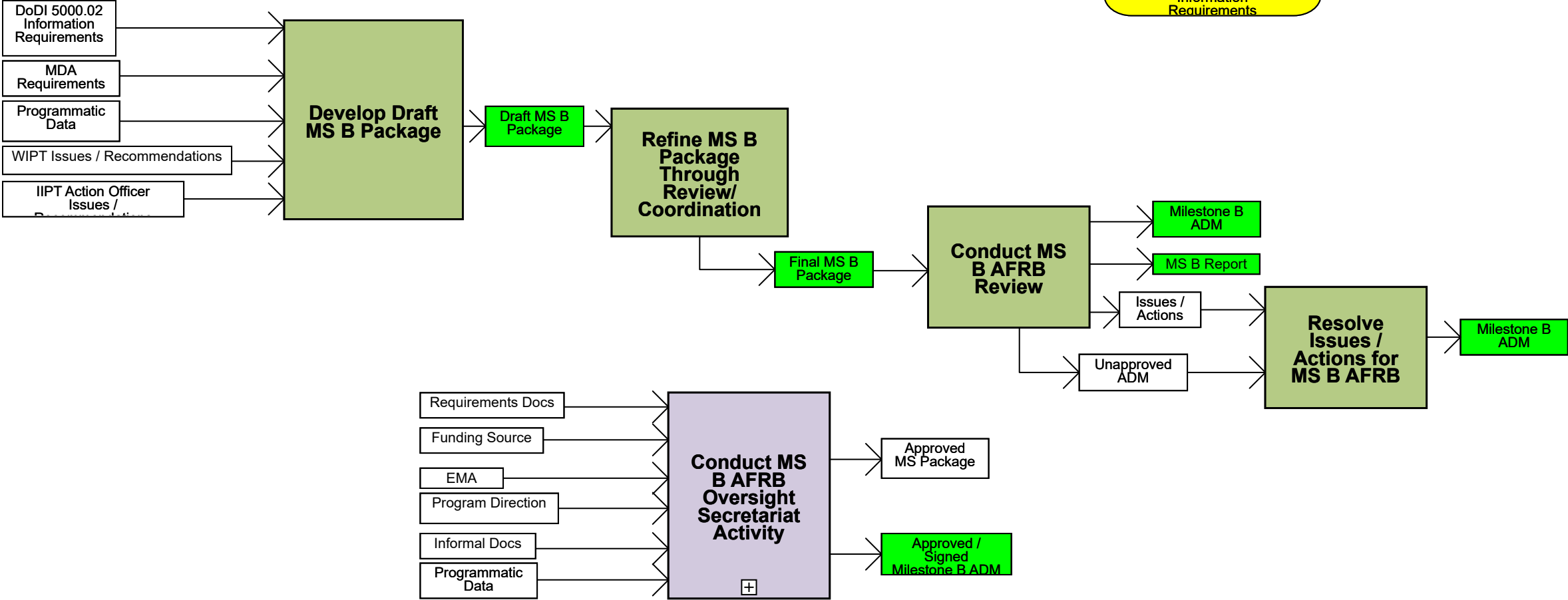

BACK FWD

Acquisition Process Model

1.1.3.10.5 Conduct Milestone B AFRB Oversight Secretariat Activity

Go Up 1 Level

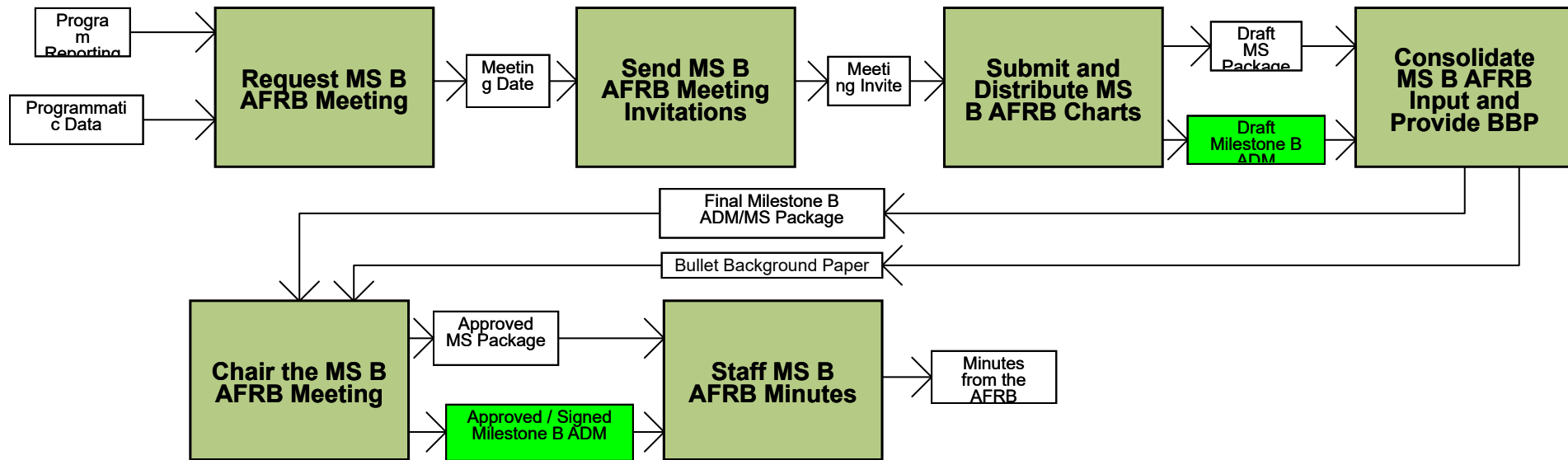

Acquisition Process Model

1.1.3.11 Milestone C AFRB

Go Up 1 Level

Milestone C Information Requirements

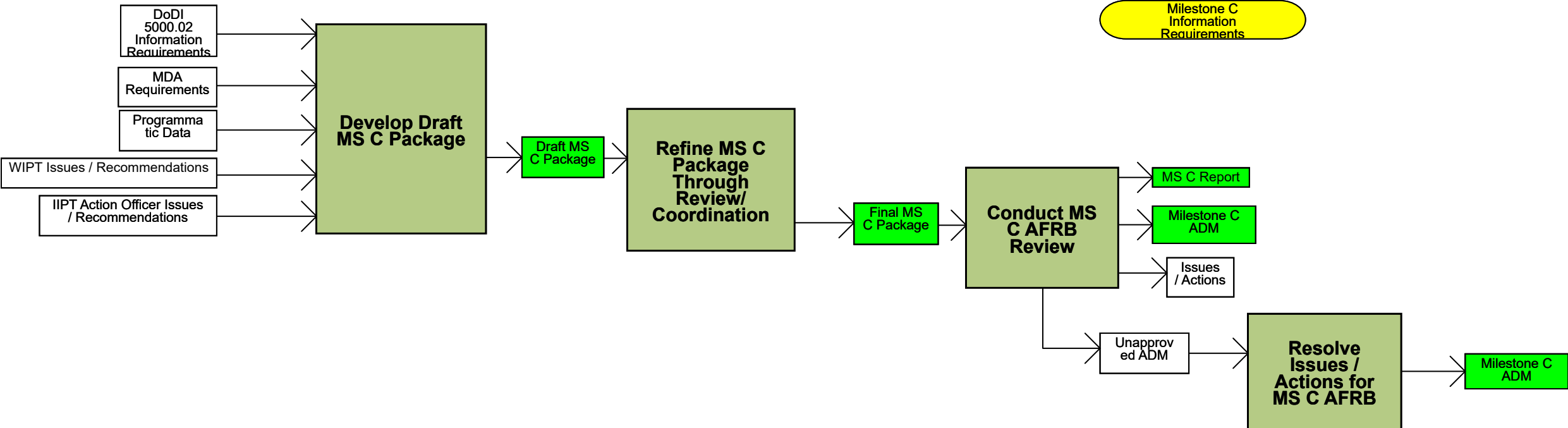

BACK FWD

Go Up 1 Level

Acquisition Process Model

1.1.3.11.5 Conduct Milestone C AFRB Oversight Secretariat Activity

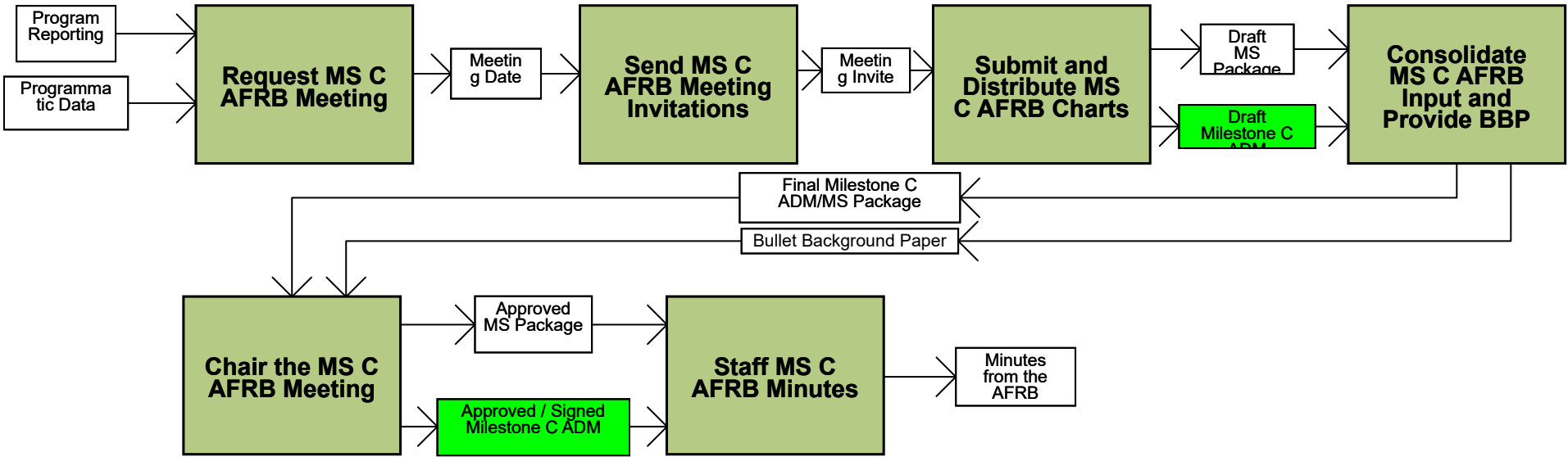

Go Up 1 Level

Acquisition Process Model

1.1.3.12 Full Rate Production DR AFRB

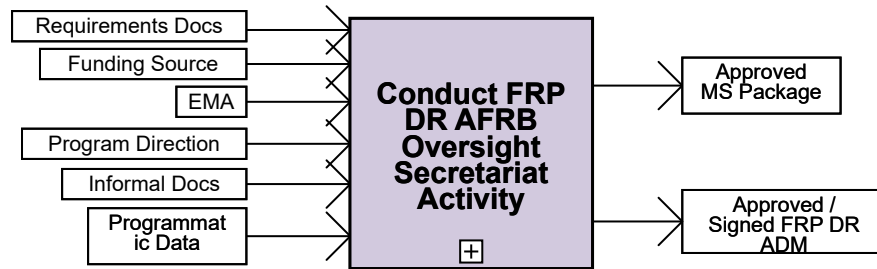
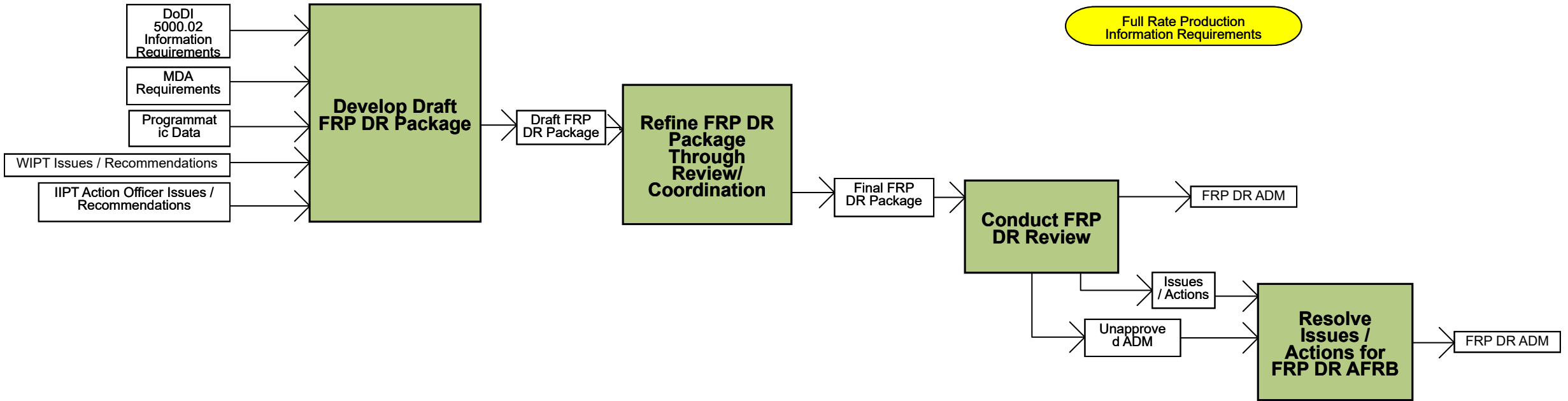

← BACK FWD →

Acquisition Process Model

1.1.3.12.5 Conduct FRP DR AFRB Oversight Secretariat Activity

Go Up 1 Level

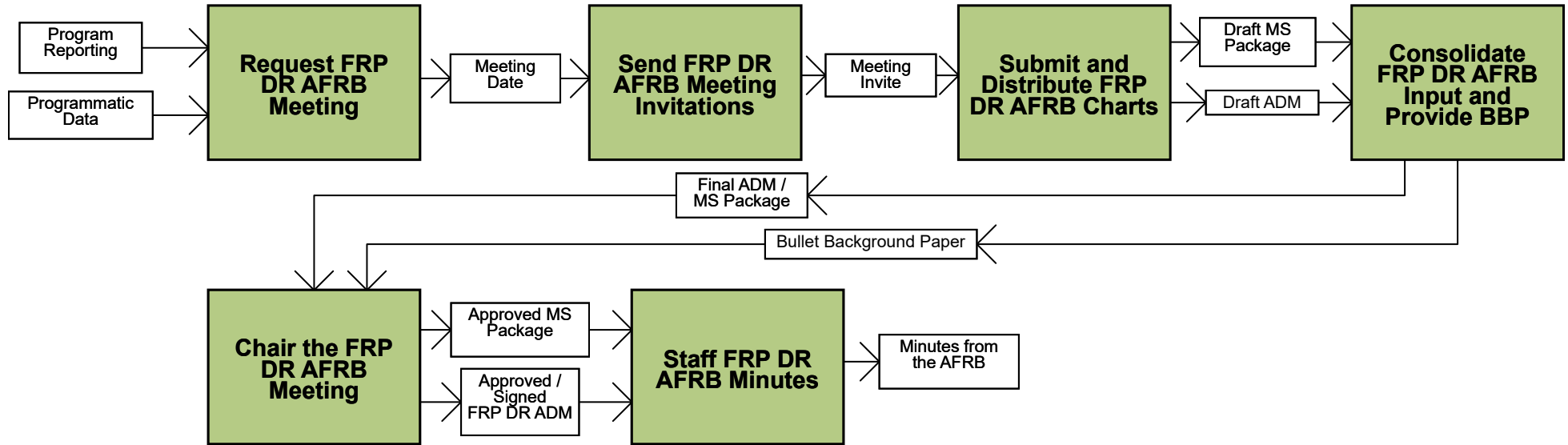

Go Up 1 Level

Acquisition Process Model

1.1.3.13 Terminate Acquisition Effort

PEO View

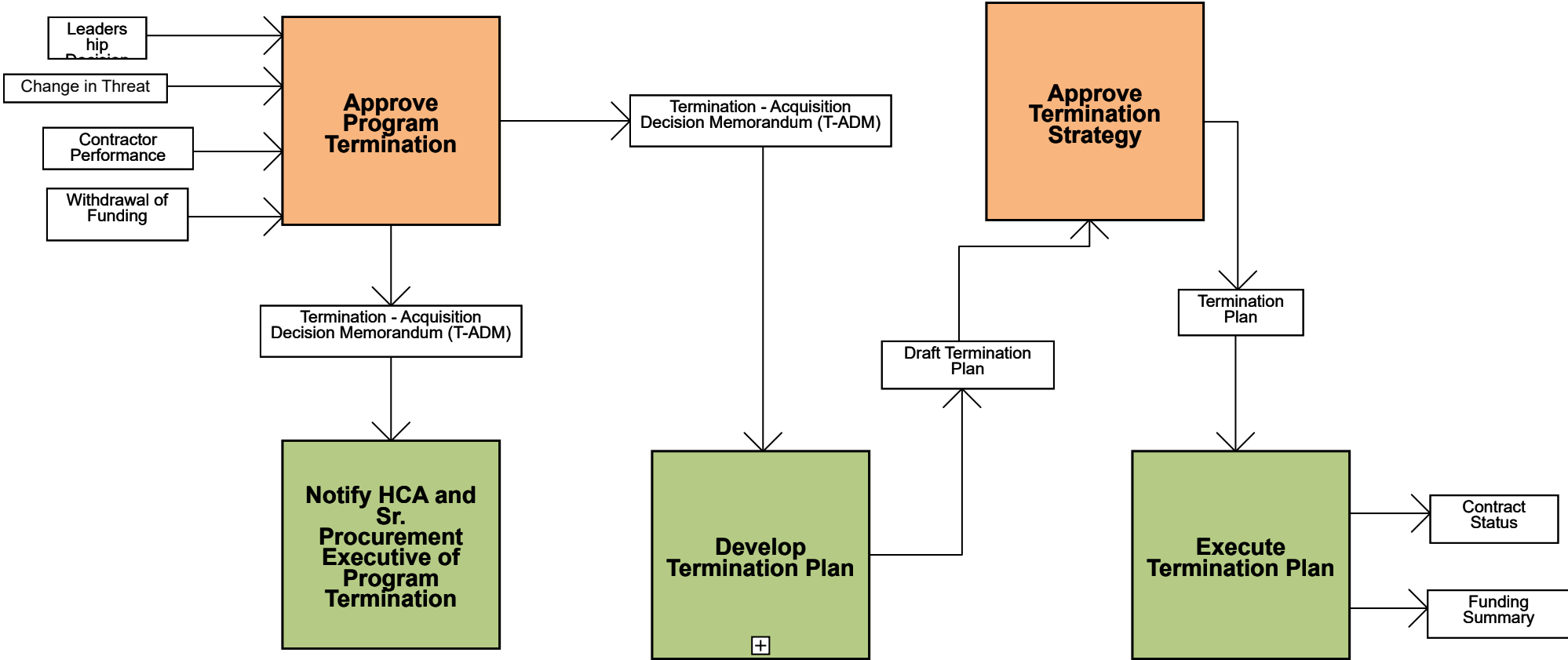

Note: Link to Gen Wolfenbarger Memo on Program Termination Procedures

← BACK



Acquisition Process Model

1.1.3.13.3 Develop Termination Plan

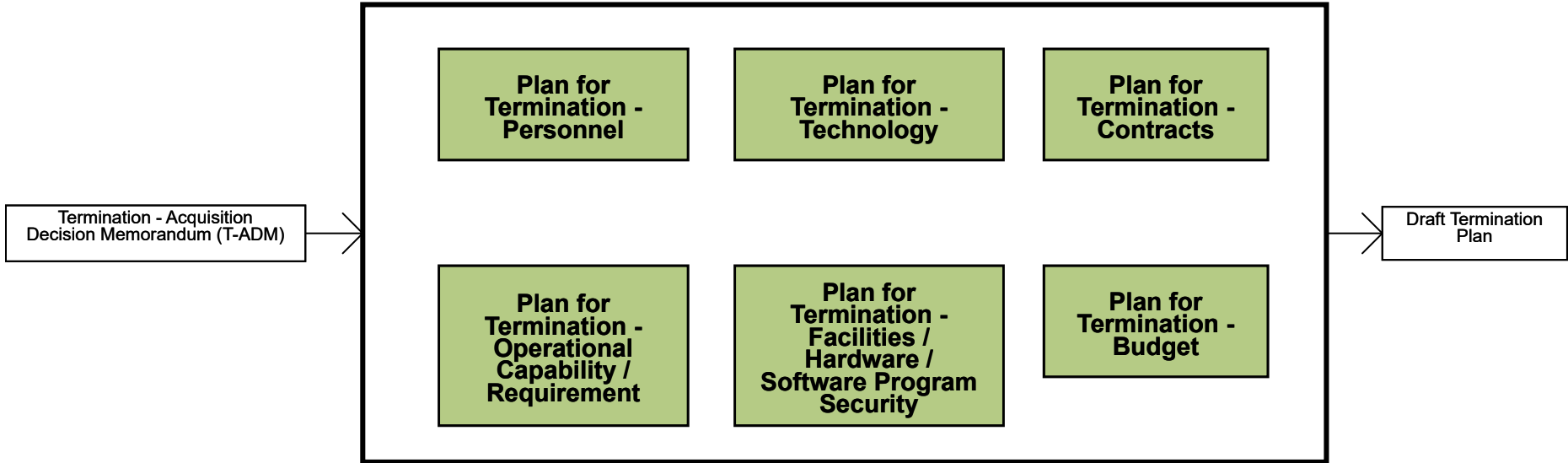

Go Up 1 Level

Acquisition Process Model

1.1.3.14 Conduct Development RFP Release Review

PEO View

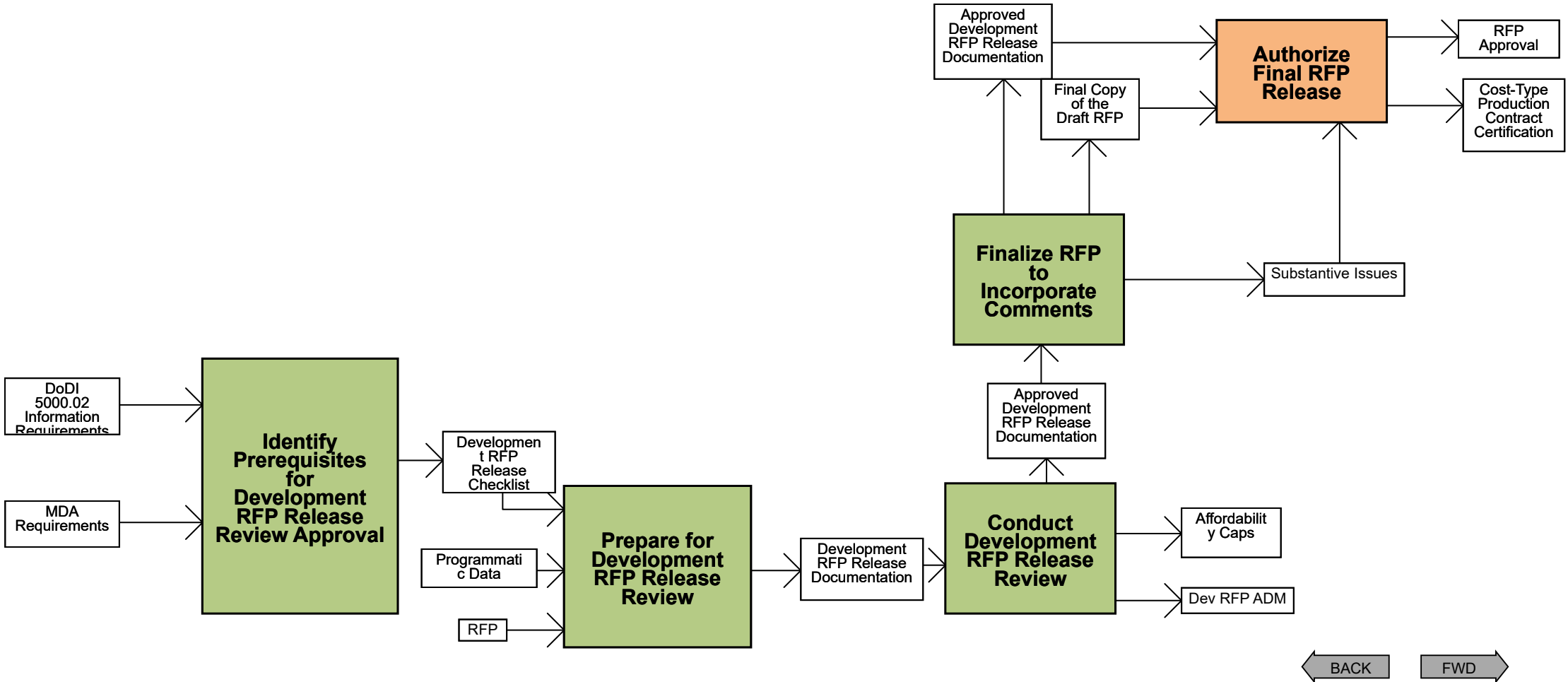

← BACK

FWD →

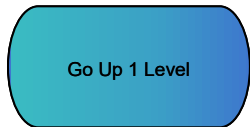

Acquisition Process Model

1.1.3.16 Defense Business Council (DBC)

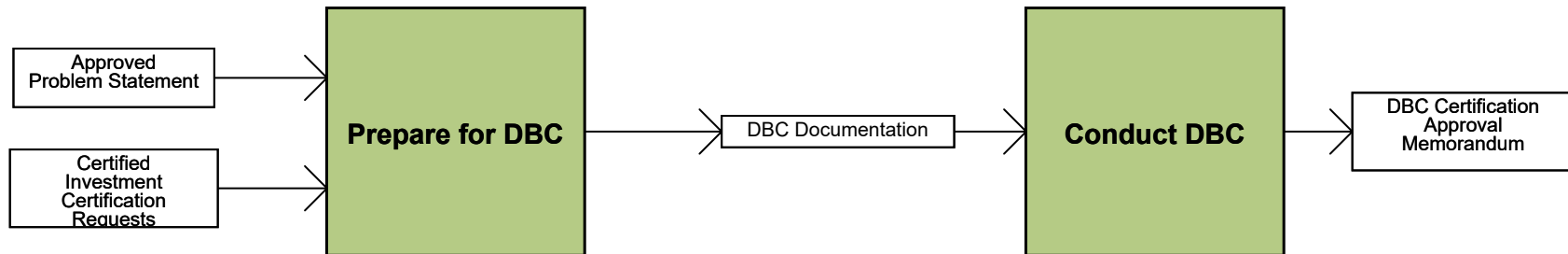

Acquisition Process Model

1.1.3.17 Development RFP AFRB

Go Up 1 Level

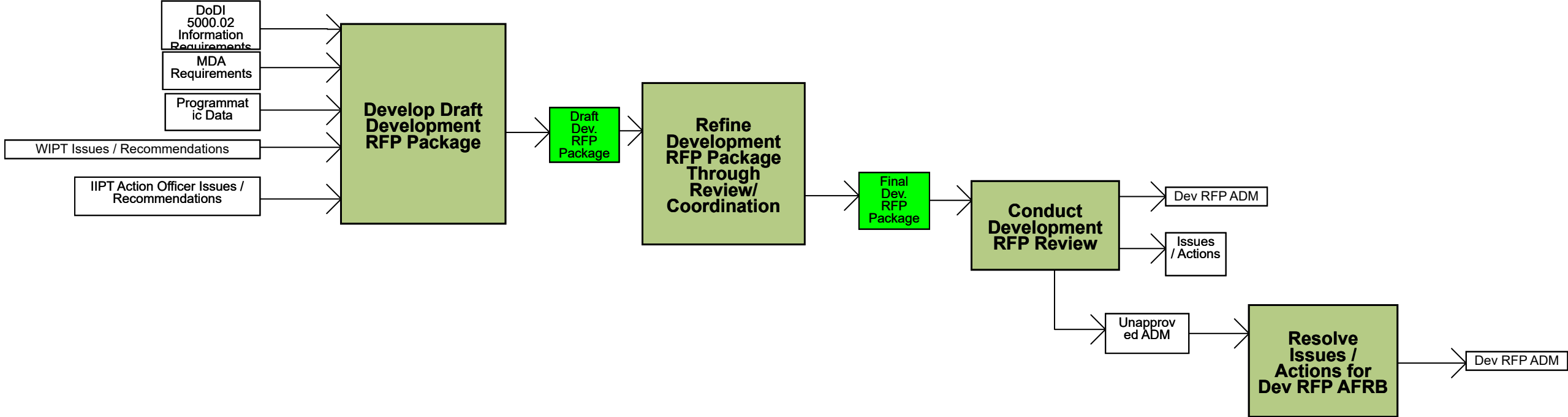

Note from the Chief Process Officer: The Dev RFP Release ASP is combined with this AFRB.

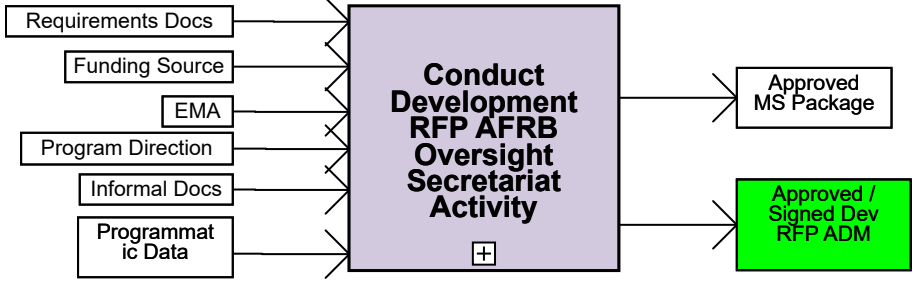

← BACK

Acquisition Process Model

1.1.3.17.5 Conduct Development RFP AFRB Oversight Secretariat Activity

Go Up 1 Level

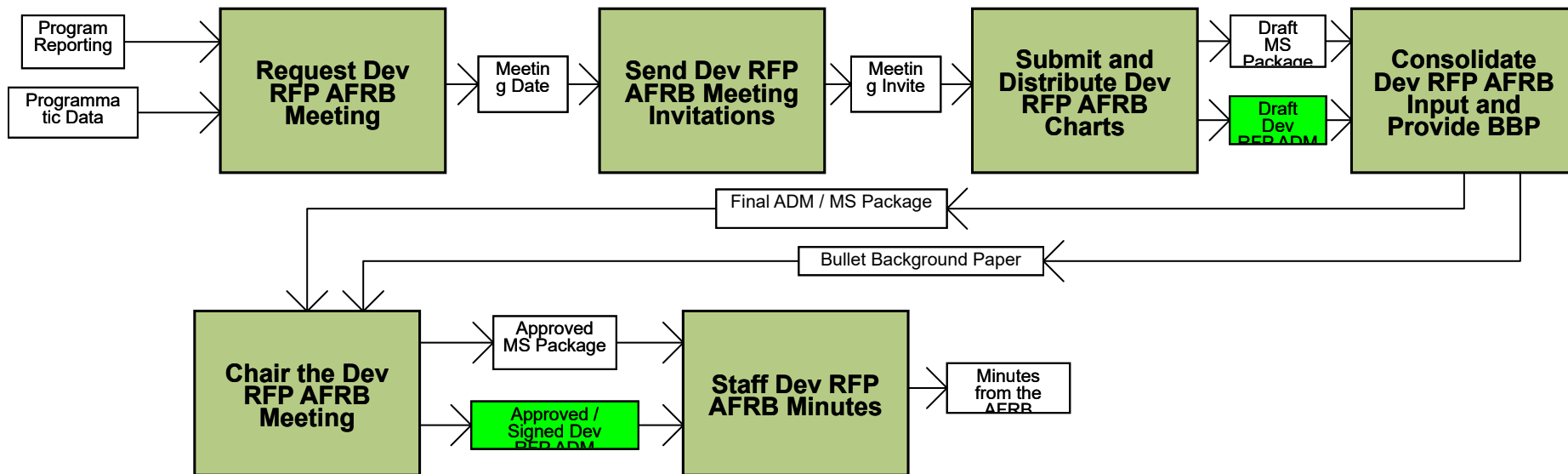

Note from the Chief Process Officer: The Dev RFP Release ASP is combined with this AFRB.

Go Up 1 Level

Acquisition Process Model

1.1.3.2 Perform AFROC (Capability Documents)

PEO View

Scenario: Develop ICD

Scenario: Develop CDD

Scenario: Develop CPD

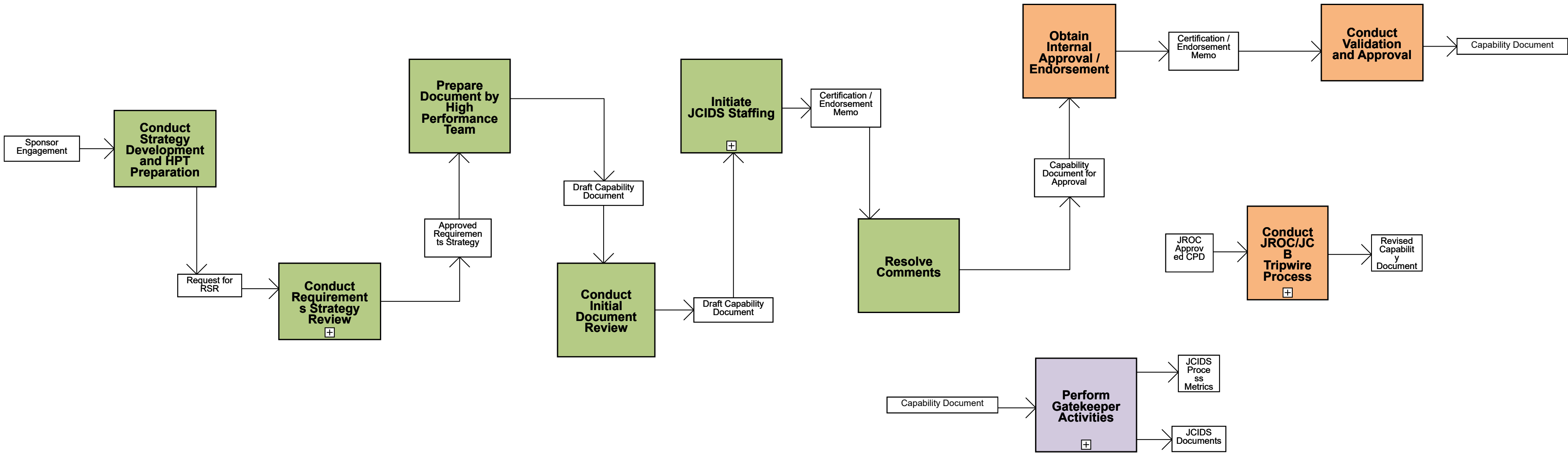

Note 1: All processes feed the Gatekeeper Activities process

Note 2: The following KPPs are mandatory in requirements documents per JCIDS Manual: Force Protection KPP, System Survivability KPP, Sustainment KPP, Net-Ready KPP, Training KPP and Energy KPP. The following KSAs are mandatory in AF requirements documents: the Flight Simulator KSA.

Note 3: Inputs Vary Based on the Capability Documents

FWD



Acquisition Process Model

1.1.3.2.1 Conduct Requirements Strategy Review (RSR)

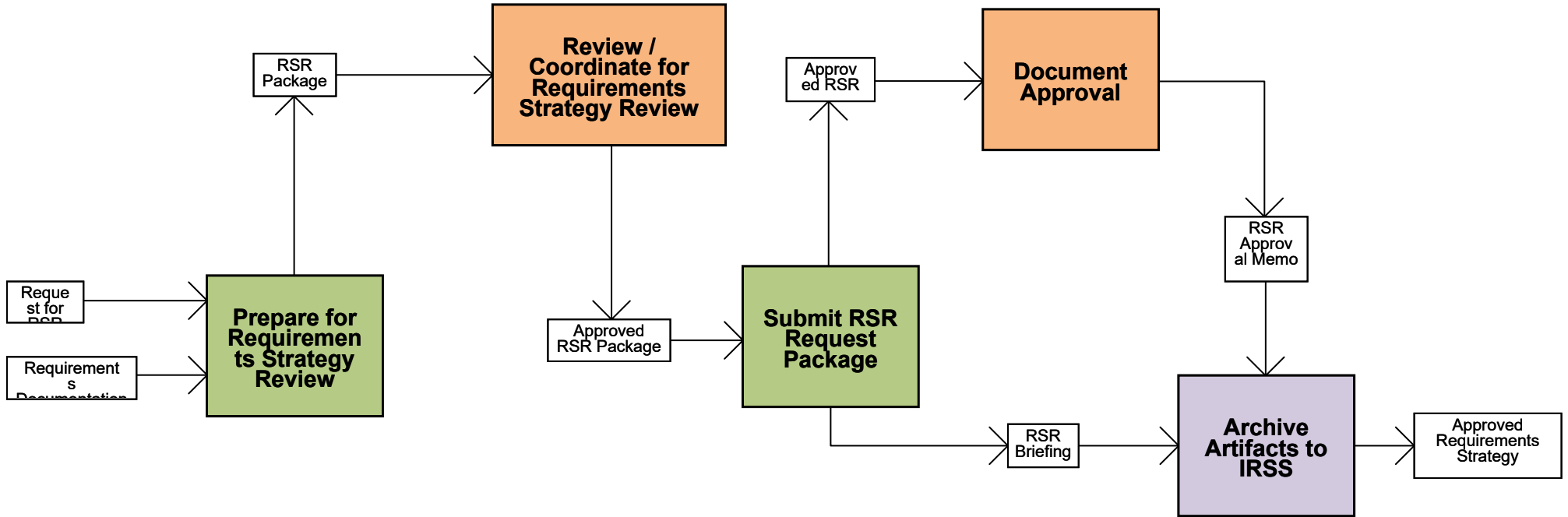

Go Up 1 Level

Acquisition Process Model

1.1.3.2.7 Initiate JCIDS Staffing

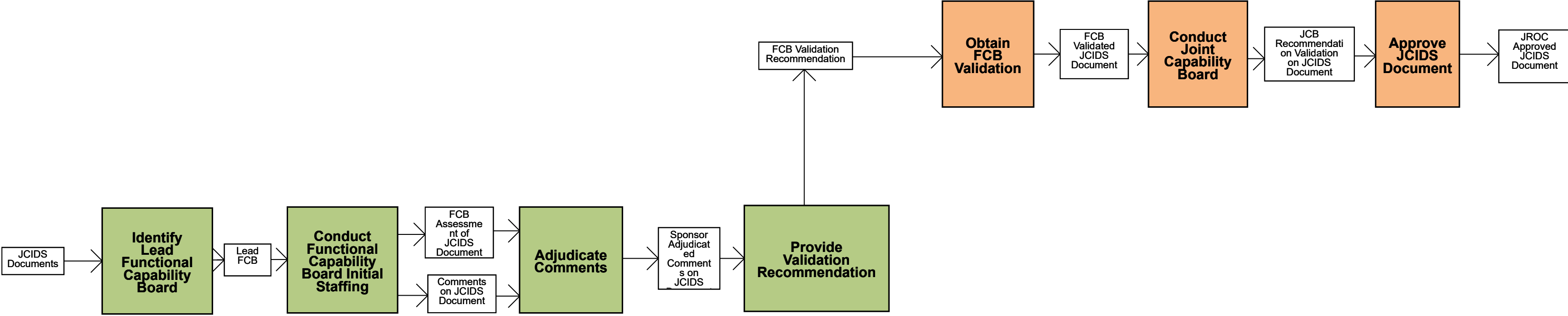

Note 1: Inputs Vary Based on the Capability Documents

Note 2: Staffing Process outlined in AFI 10-601 Chapter 5 is consistent with JCIDS Manual Enclosure F Click to access a link to AFI 10-601.

← BACK

FWD →

Go Up 1 Level

Acquisition Process Model

1.1.3.2.8 Perform Gatekeeper Activities

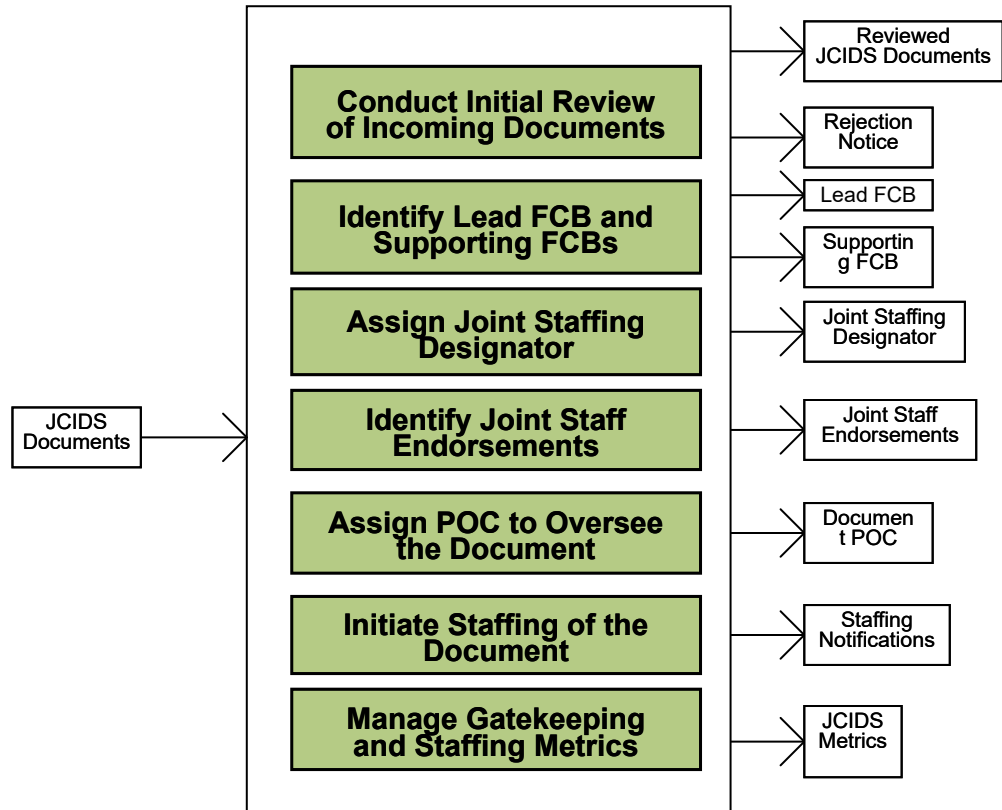

Note: Inputs Vary Based on the Capability Documents

← BACK

FWD →

Go Up 1 Level

Acquisition Process Model

1.1.3.2.9 Conduct JROC JCB Tripwire Process

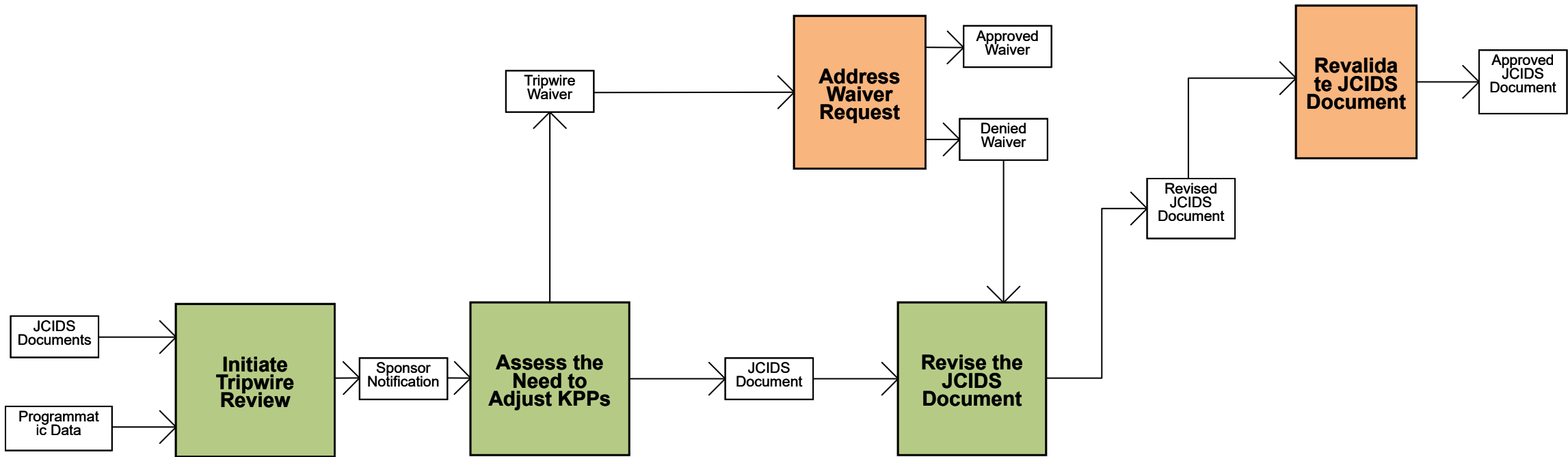

Note: Inputs Vary Based on the Capability Documents

← BACK

Go Up 1 Level

Acquisition Process Model

1.1.3.3 Acquisition Strategy Panel (ASP) - Center Level

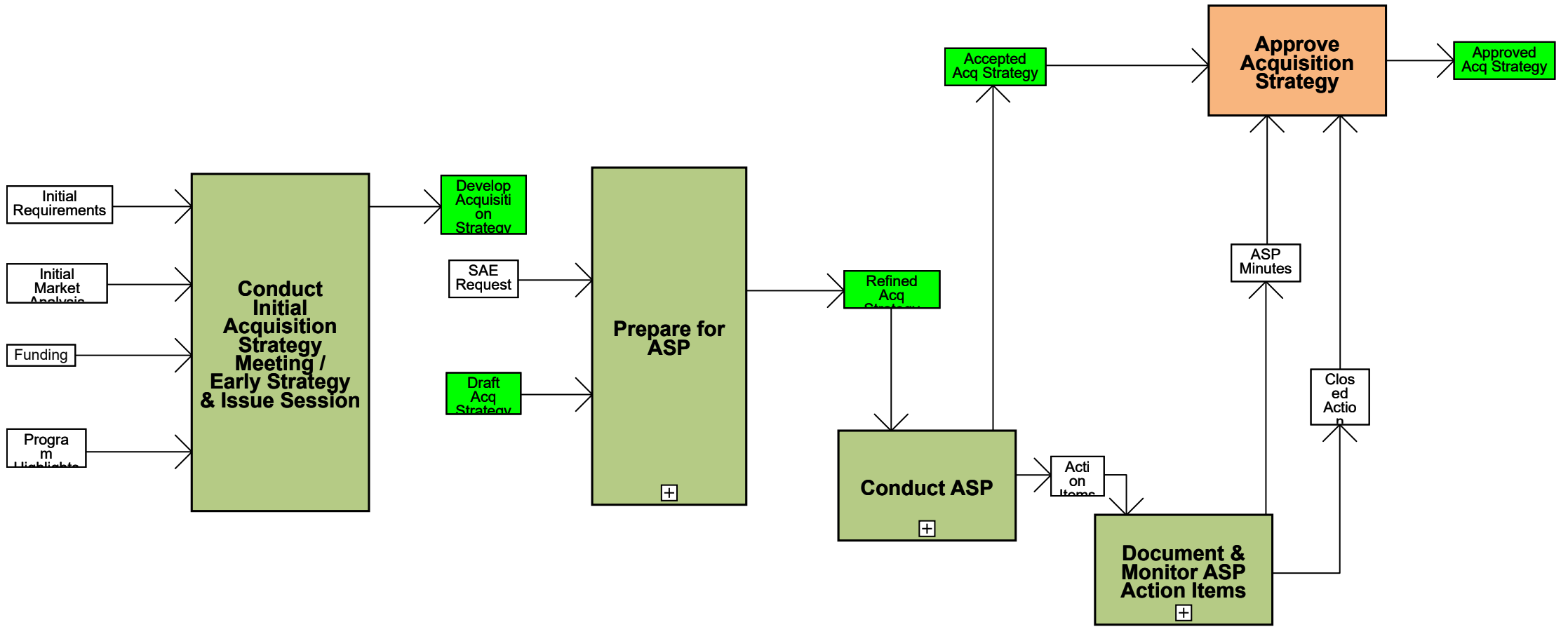

Note: For information regarding Small Business ASP click the link below:
[1.2 Acquisition Planning](#)

← BACK FWD →

Go Up 1 Level

Acquisition Process Model

1.1.3.3 Acquisition Strategy Panel (ASP)

PEO View

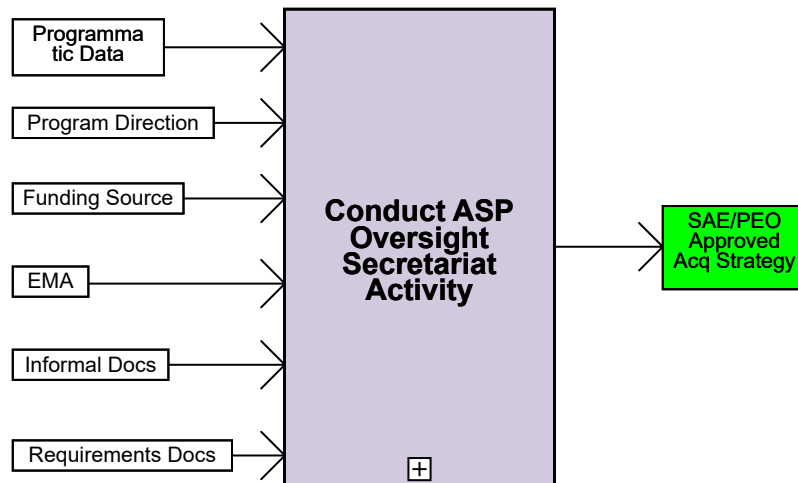
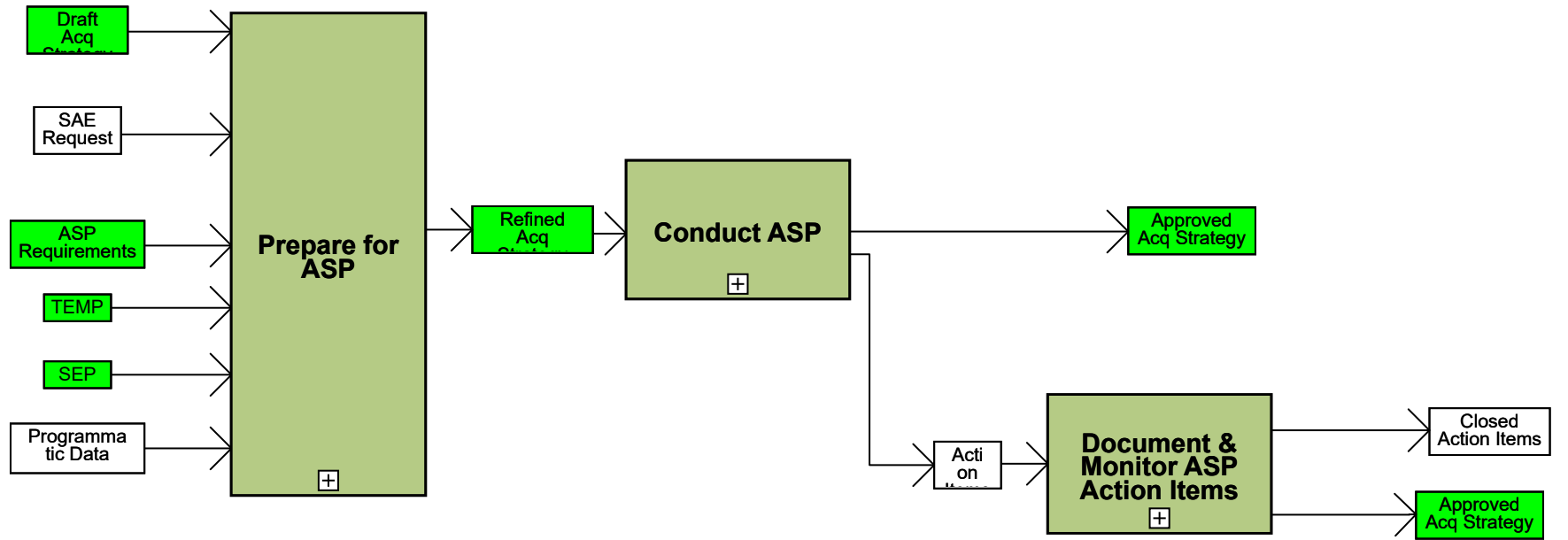

Note: For information regarding Small Business ASP click the link below:
[1.2 Acquisition Planning](#)

← BACK FWD →

Go Up 1 Level

Acquisition Process Model

1.1.3.3.2 Prepare for ASP

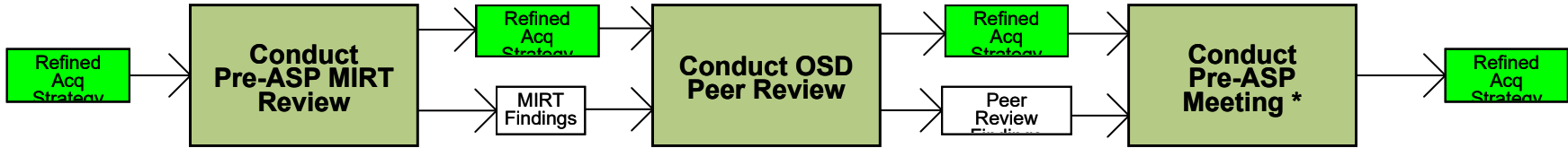

Note 1: This is an AFMC Standard Process. It is included in this model in advance of Streamlining and Redesign.

Note 2: The purpose of the Pre-ASP is to target one level below the ASP Chair. This may occur at multiple levels and also may occur prior to the OSD Peer Review.

FWD →

Go Up 1 Level

Acquisition Process Model

1.1.3.3.3 Conduct ASP

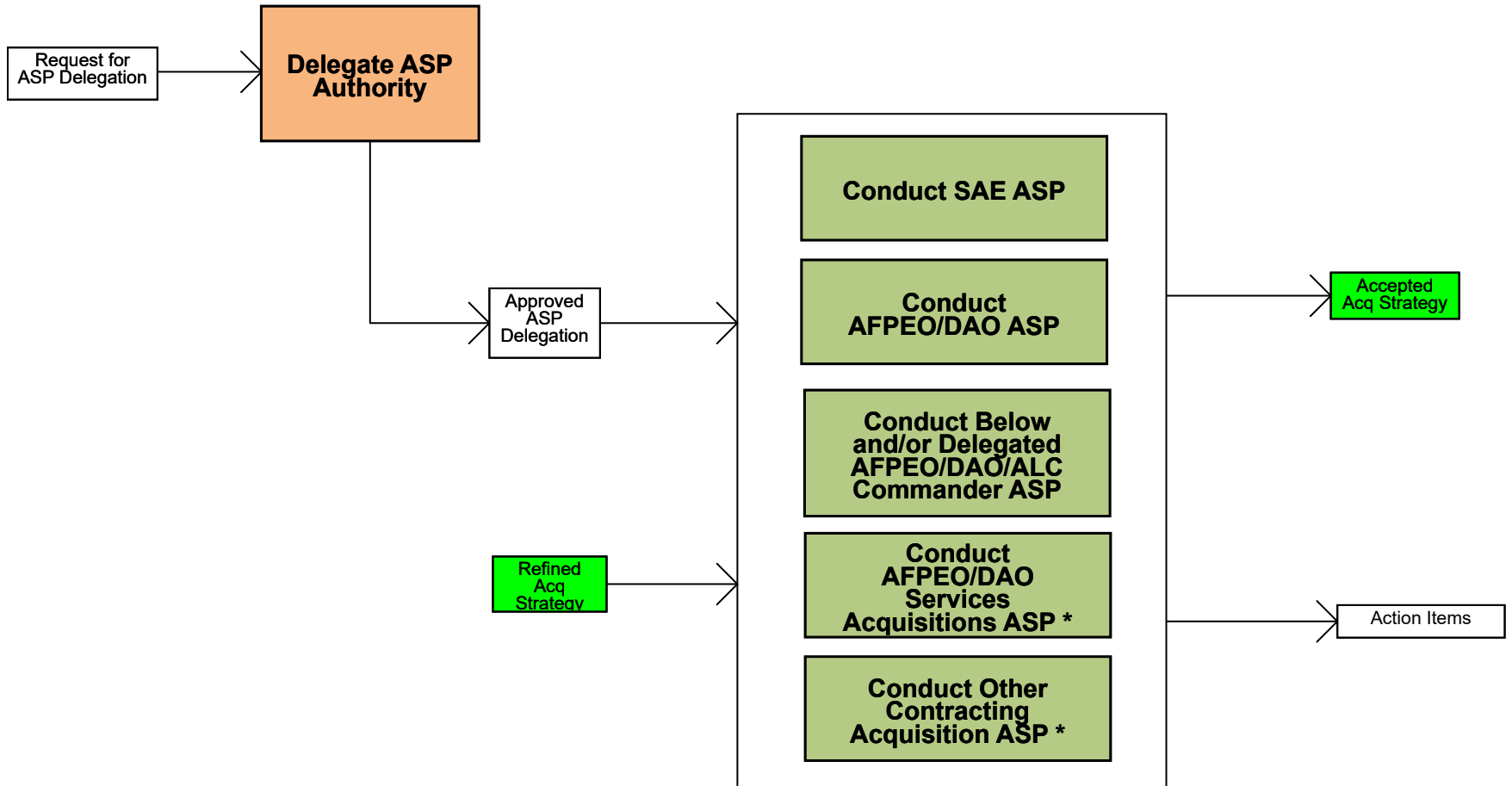

Note: The model does not currently address Services processes.

BACK FWD

Go Up 1 Level

Acquisition Process Model

1.1.3.3.4 Document & Monitor ASP Action Items

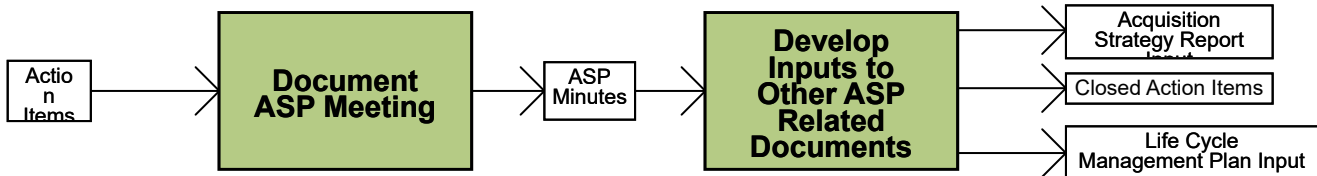

Note: This is an AFMC Standard Process. It is included in this model in advance of Streamlining and Redesign

BACK FWD

Go Up 1 Level

Acquisition Process Model

1.1.3.3.5 Oversight Secretariat Activity

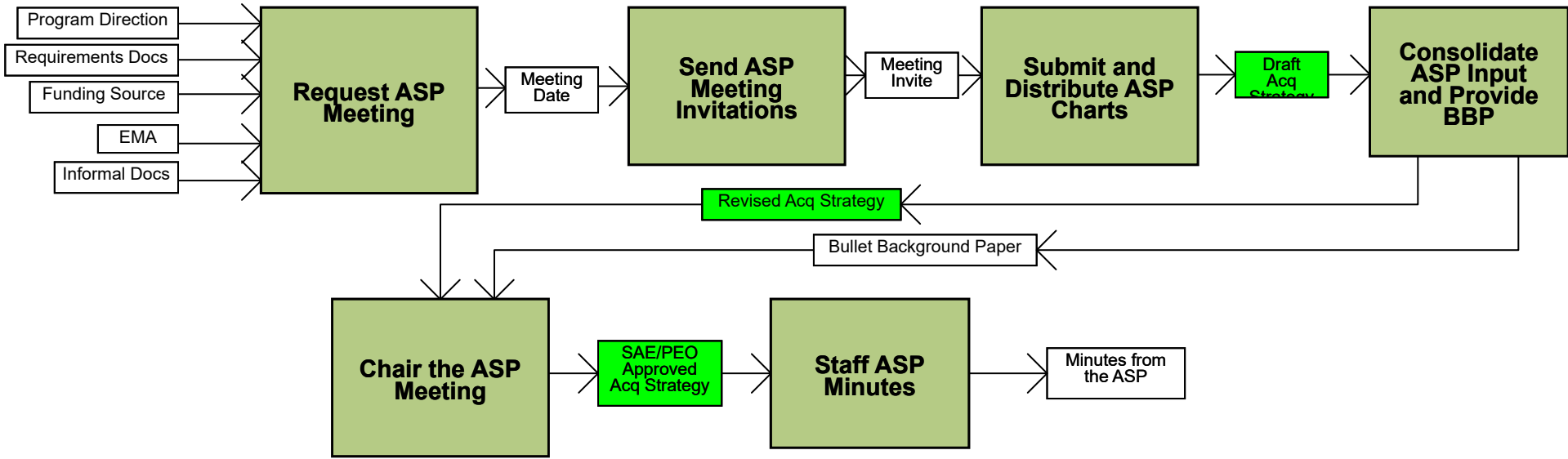

← BACK

Go Up 1 Level

Acquisition Process Model

1.1.3.4 Milestone A Review

PEO View

Milestone A Information Requirements

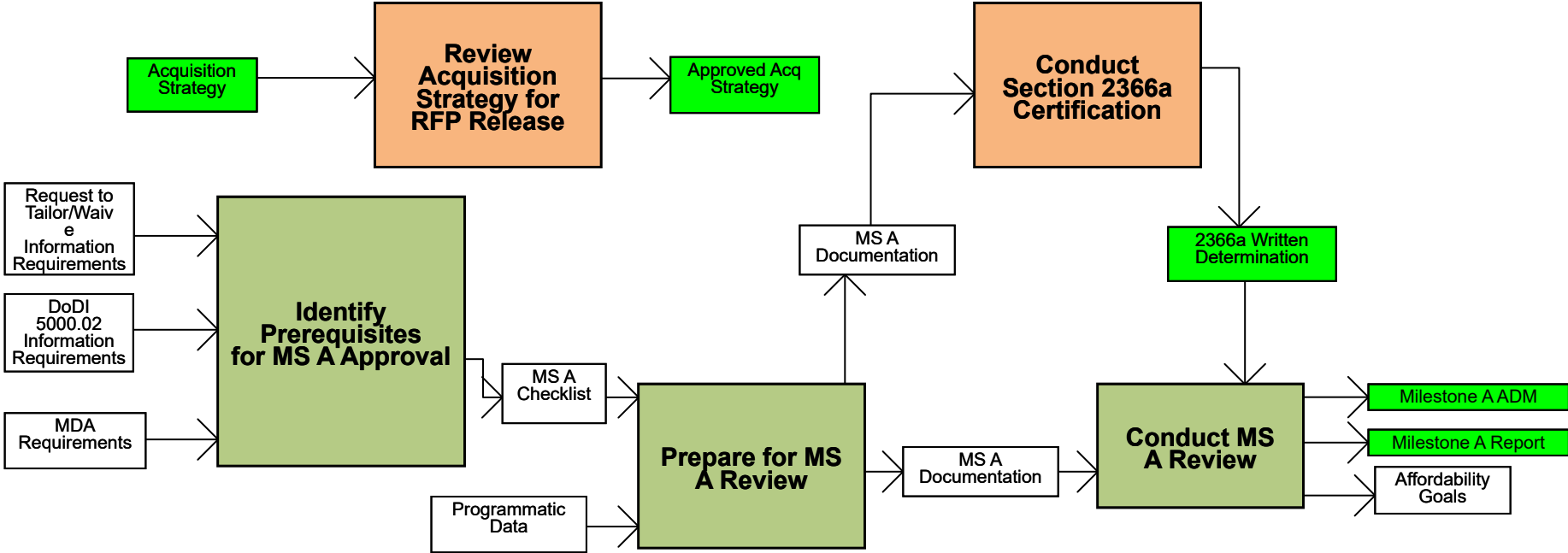

Note 1: The MDA is strongly encouraged to tailor the reporting requirements consistent with Enclosure 1, Table 2 of the DoDI 5000.02

Note 2: The purpose of program tailoring is to streamline the acquisition program to the maximum extent possible, consistent with risk, to provide new systems to operational commanders as fast as possible. DoDI 5000.02, Section 5.a.2; AFPAM 63-128, Section 14.1

← BACK

FWD →

Go Up 1 Level

Acquisition Process Model

1.1.3.5 Milestone B Review

PEO View

Milestone B Information Requirements

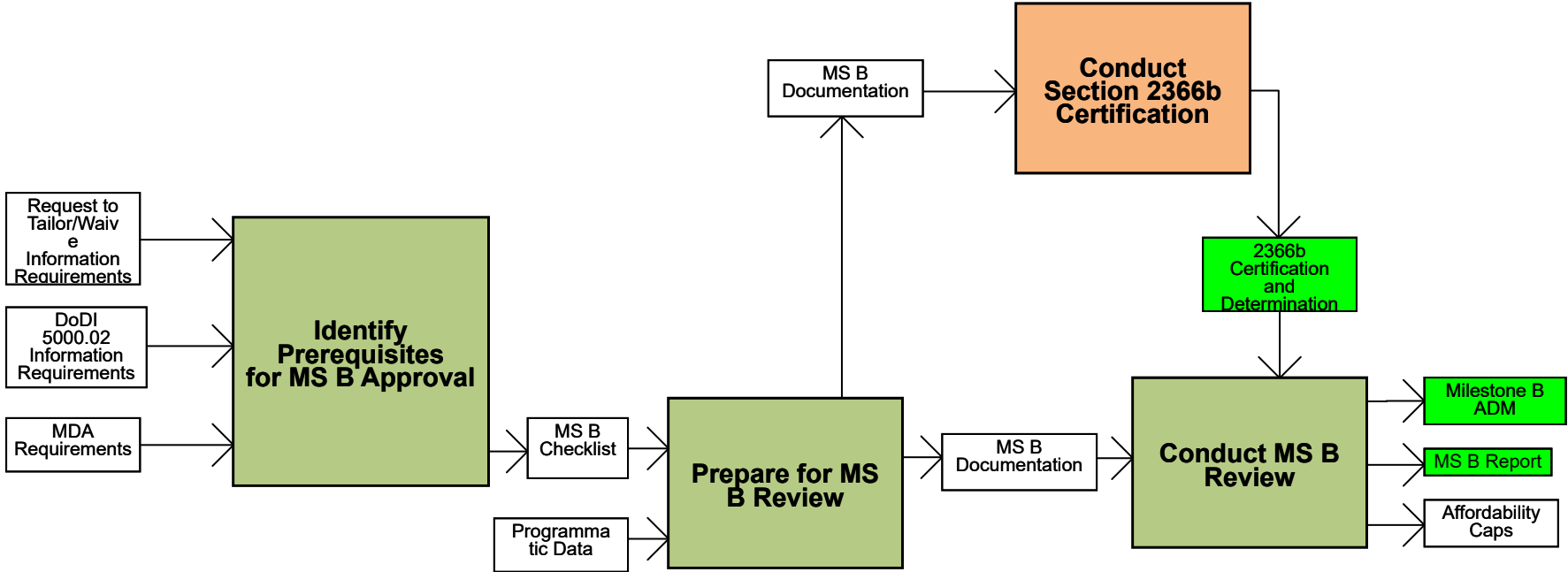

Note 1: The MDA is strongly encouraged to tailor the reporting requirements consistent with Enclosure 1, Table 2 of the DoDI 5000.02

Note 2: The purpose of program tailoring is to streamline the acquisition program to the maximum extent possible, consistent with risk, to provide new systems to operational commanders as fast as possible. DoDI 5000.02, Section 5.a.2; AFPAM 63-128, Section 14.1

BACK FWD

Go Up 1 Level

Acquisition Process Model

1.1.3.6 Milestone C Review

PEO View

Milestone C Information Requirements

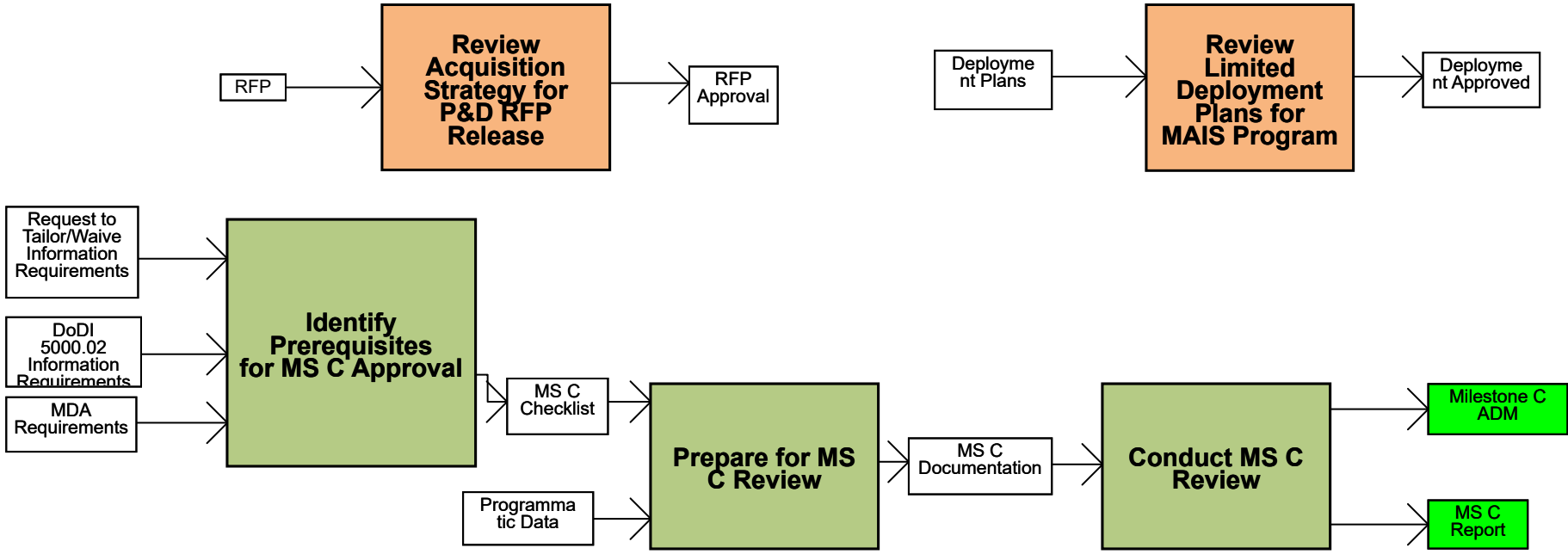

Note 1: The MDA is strongly encouraged to tailor the reporting requirements consistent with Enclosure 1, Table 2 of the DoDI 5000.02

Note 2: The purpose of program tailoring is to streamline the acquisition program to the maximum extent possible, consistent with risk, to provide new systems to operational commanders as fast as possible. DoDI 5000.02, Section 5.a.2; AFPAM 63-128, Section 14.1

BACK FWD

Go Up 1 Level

Acquisition Process Model

1.1.3.7 Materiel Development Decision

AFLCMC
Standard
Processes

PEO View

MDD Information
Requirements

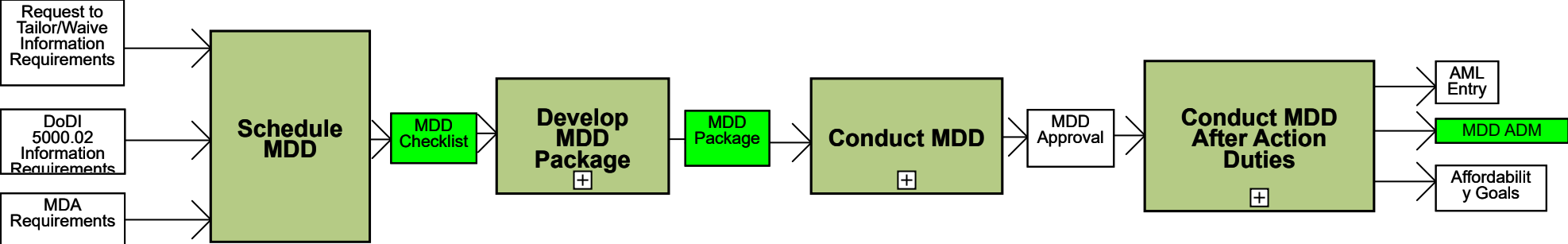

Note 1: The MDA is strongly encouraged to tailor the reporting requirements consistent with Enclosure 1, Table 2 of the DoDI 5000.02

Note 2: The purpose of program tailoring is to streamline the acquisition program to the maximum extent possible, consistent with risk, to provide new systems to operational commanders as fast as possible. DoDI 5000.02, Section 5.a.2; AFPAM 63-128, Section 14.1

Note 3: The AFLCMC specific process for Development Planning provides input for some MDD actions. Click here to access an active link to this process.

FWD

Go Up 1 Level

Acquisition Process Model

1.1.3.7.2 Develop MDD Package

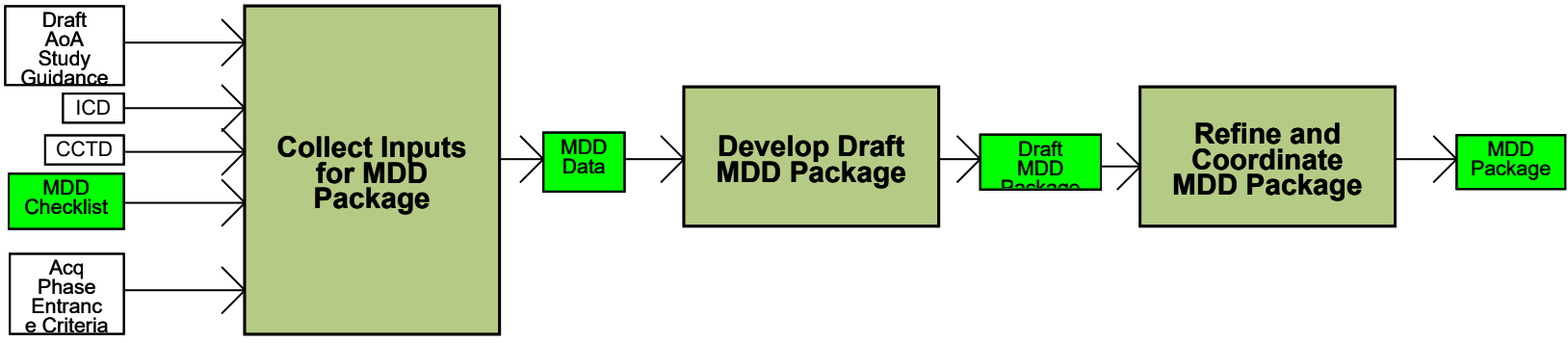

FWD

Go Up 1 Level

Acquisition Process Model

1.1.3.7.3 Conduct MDD

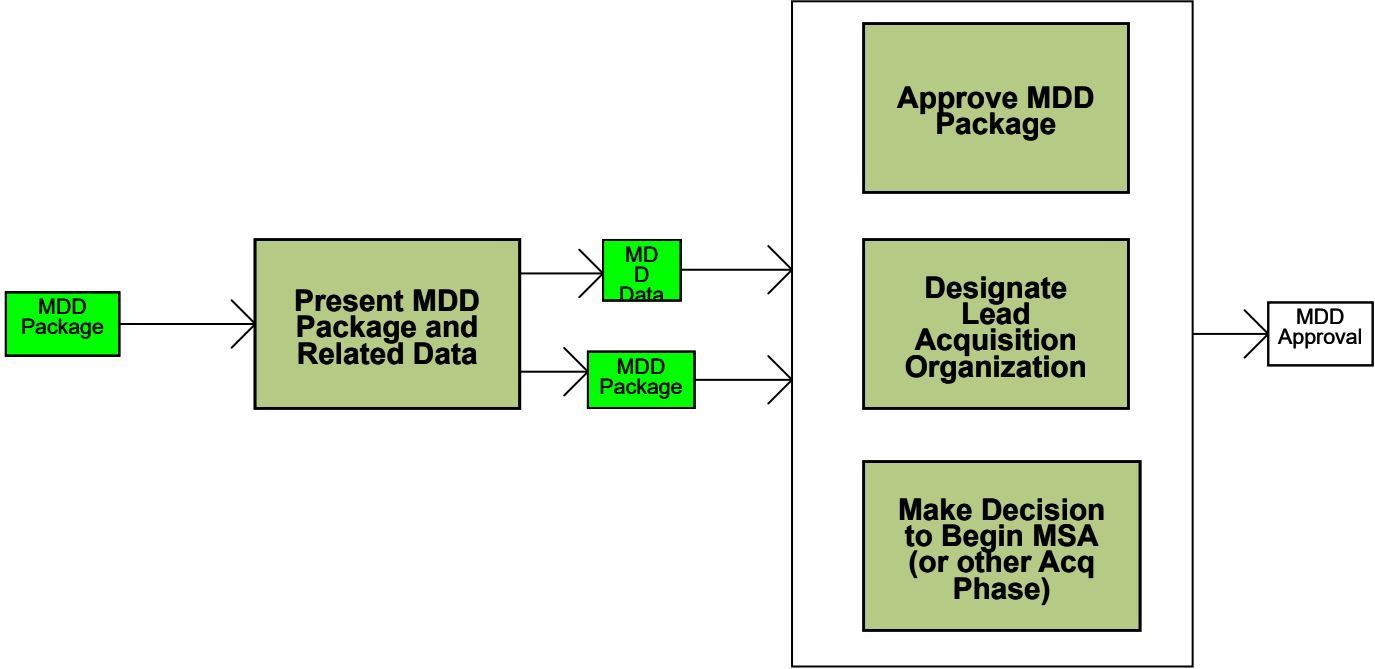

← BACK

FWD →

Go Up 1 Level

Acquisition Process Model

1.1.3.7.4 Conduct MDD After Action Duties

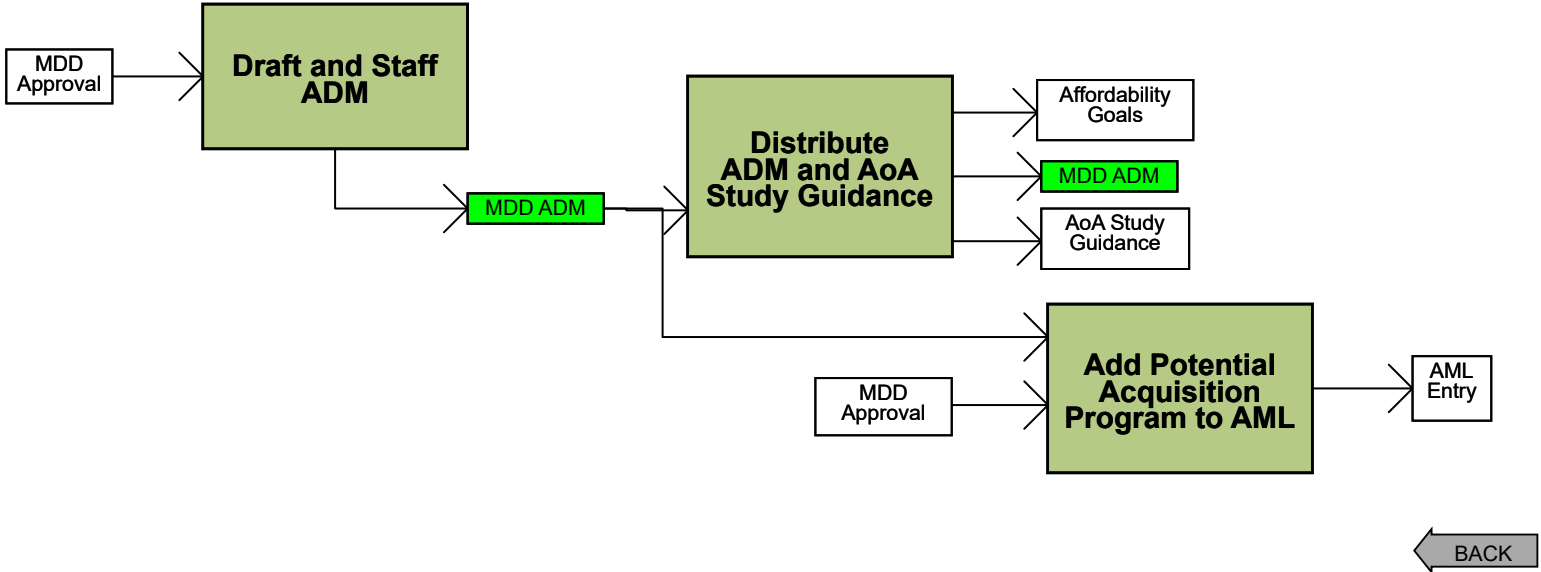

Go Up 1 Level

Acquisition Process Model

1.1.3.8 Full Rate Production

PEO View

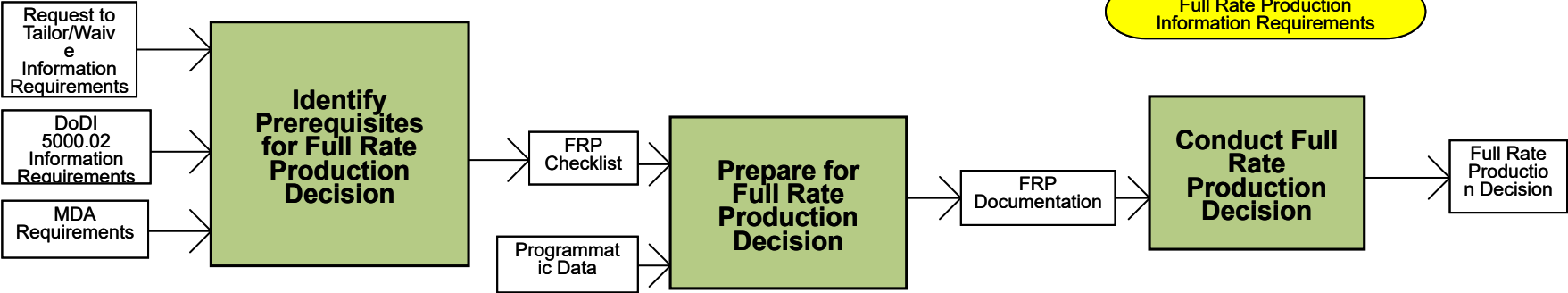

Note 1: The MDA is strongly encouraged to tailor the reporting requirements consistent with Enclosure 1, Table 2 of the DoDI 5000.02

Note 2: The purpose of program tailoring is to streamline the acquisition program to the maximum extent possible, consistent with risk, to provide new systems to operational commanders as fast as possible. DoDI 5000.02, Section 5.a.2; AFPAM 63-128, Section 14.1

BACK FWD

Acquisition Process Model

1.1.3.9 Milestone A AFRB

Go Up 1 Level

PEO View

Milestone A Information Requirements

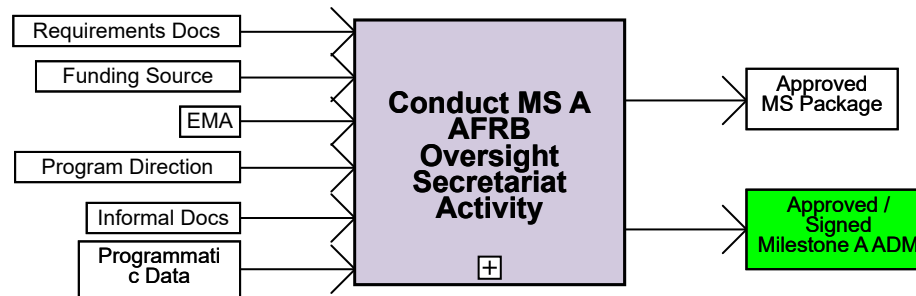
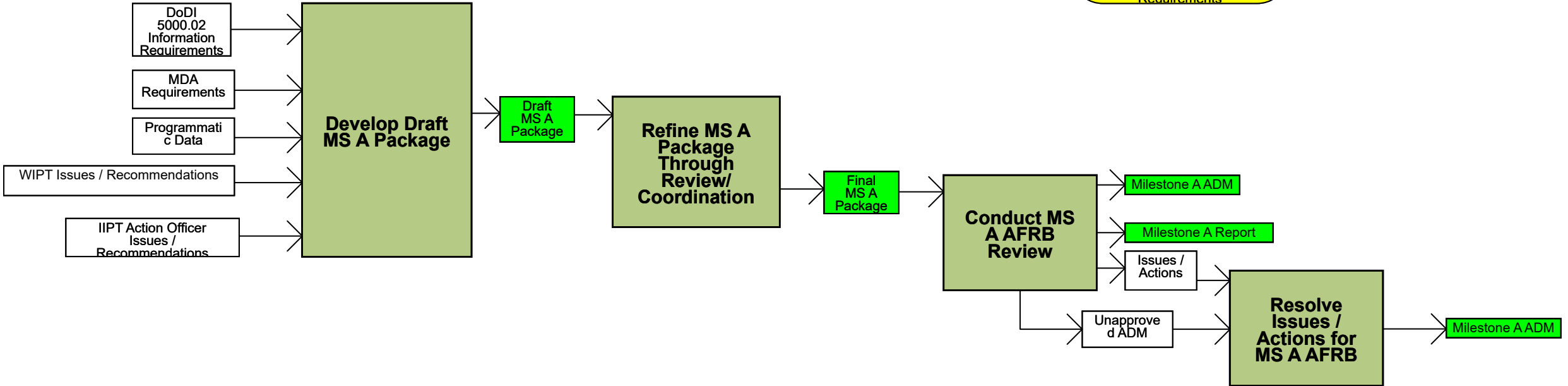

FWD

Go Up 1 Level

Acquisition Process Model

1.1.3.9.5 Conduct Milestone A AFRB Oversight Secretariat Activity

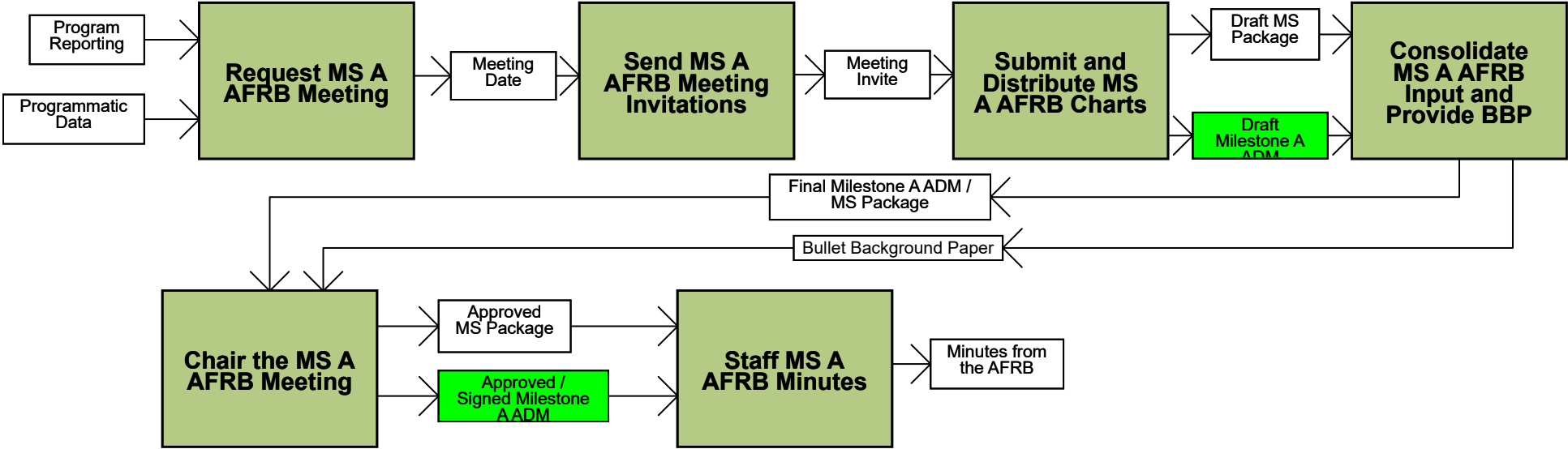

Go Up 1 Level

Acquisition Process Model

1.1.4 Technical Reviews

PEO View

1.1.3.7
MDD

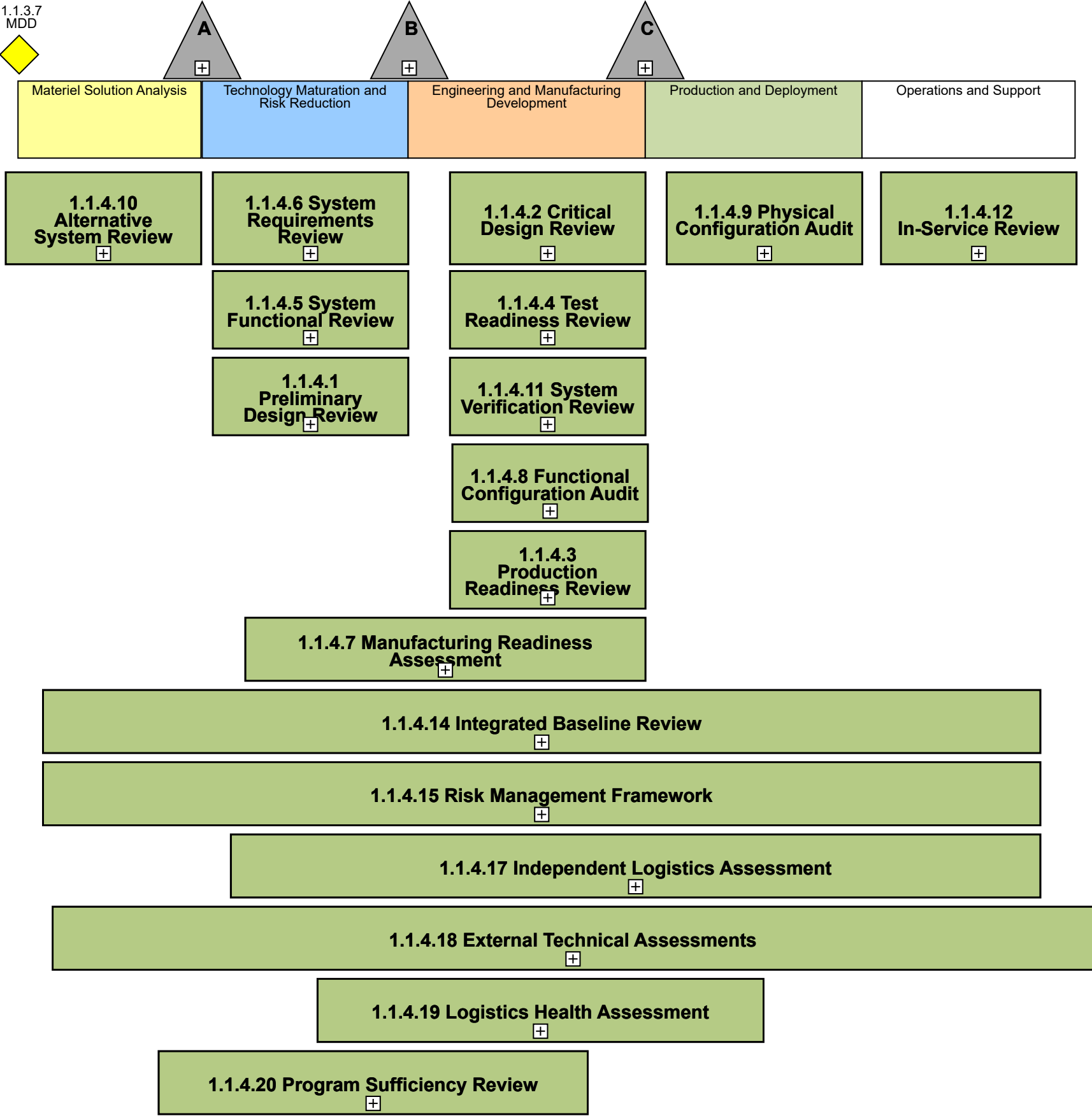

Note 1: Prior to SAF/AQR-chaired reviews of a program, representatives of the PEO or PM for the program and the Center-level engineering office supporting the program provide SAF/AQR with their assessments of the program's technical status. (AFI 63-101/20-101, Section 5.1.6.2)

Note 2: Program Sufficiency Review is an AFLCMC Process Guide

← BACK

FWD →

Go Up 1 Level

Acquisition Process Model

1.1.4.1 Preliminary Design Review (PDR)

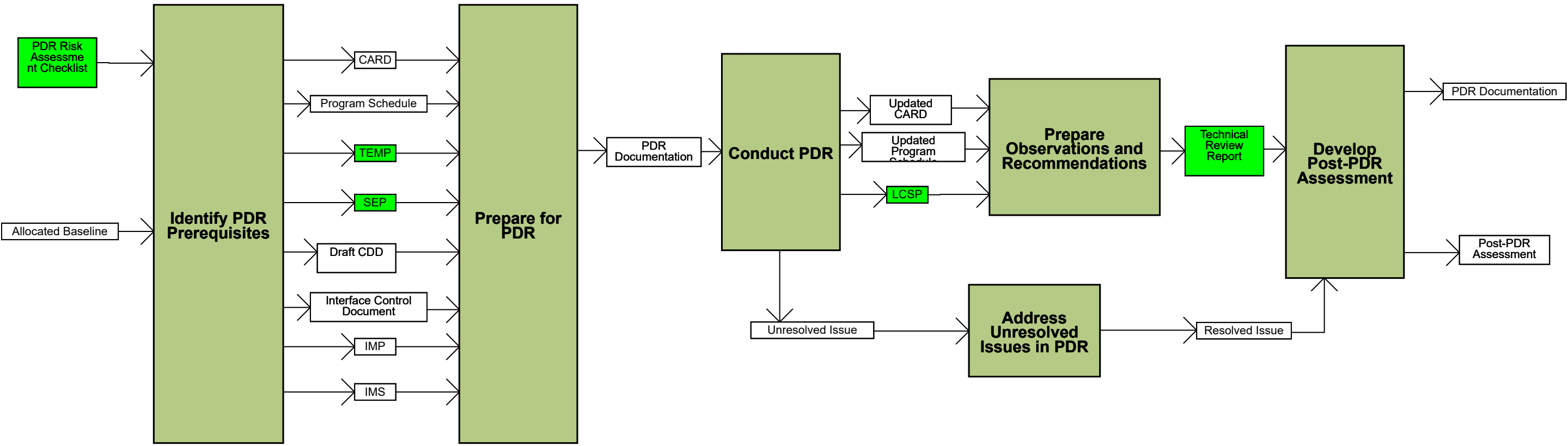

FWD

Go Up 1 Level

Acquisition Process Model

1.1.4.10 Alternative Systems Review (ASR)

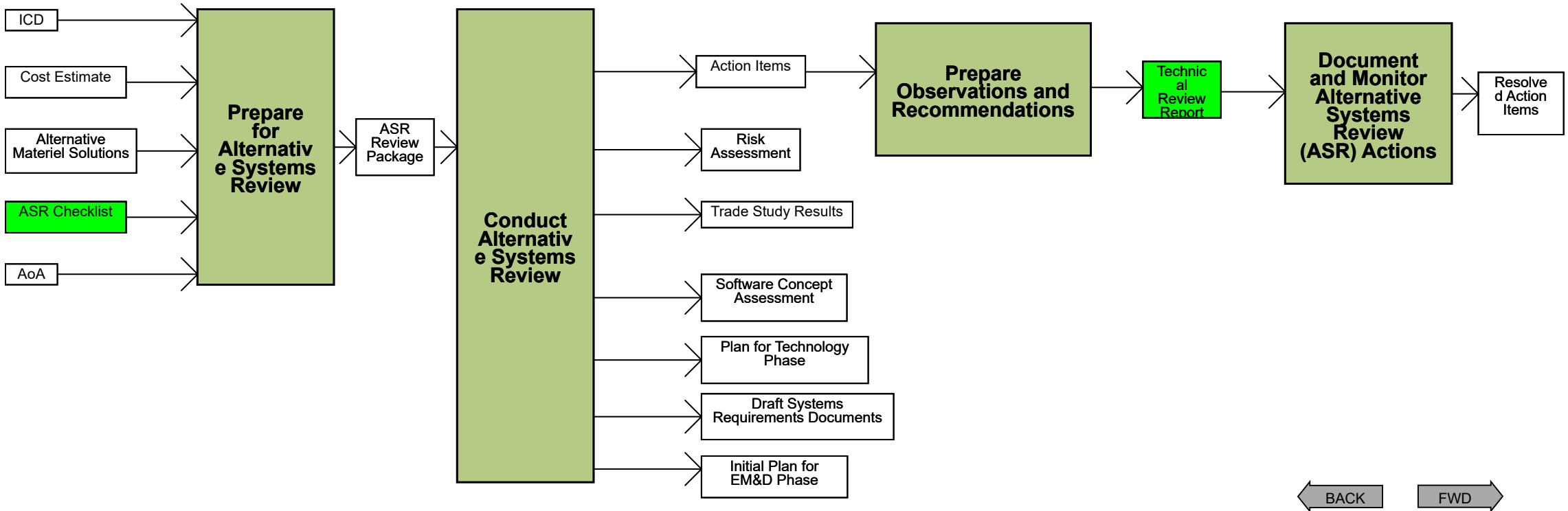

← BACK

FWD →



Acquisition Process Model

1.1.4.11 System Verification Review (SVR)

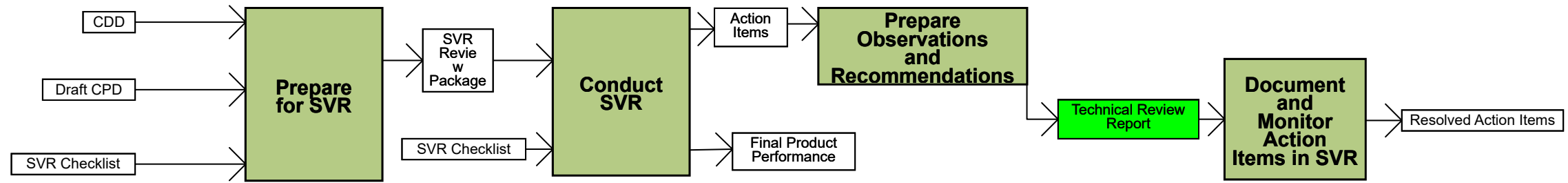

Go Up 1 Level

Acquisition Process Model

1.1.4.12 In-Service Review (ISR)

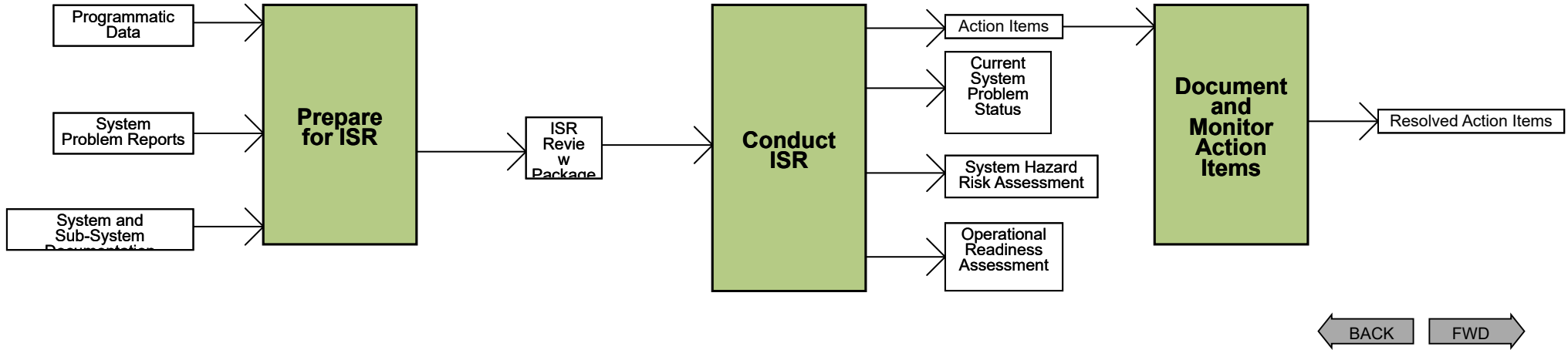

Go Up 1 Level

Acquisition Process Model

1.1.4.14 Conduct Integrated Baseline Review (IBR)

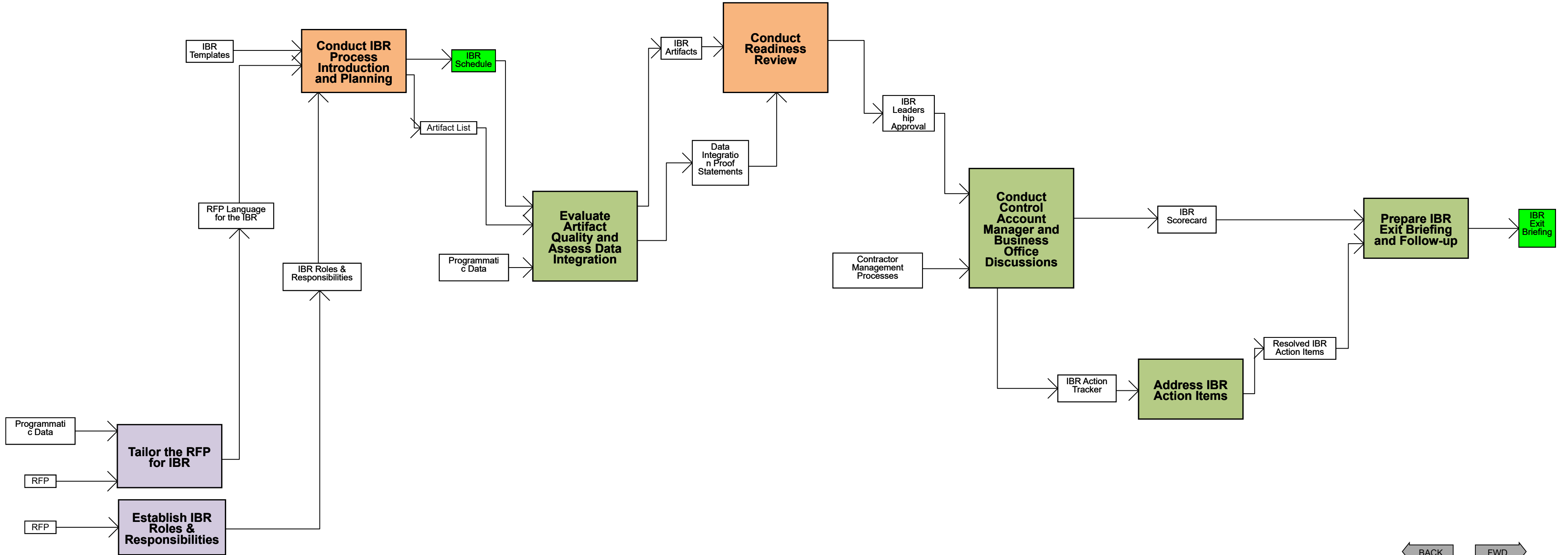

BACK

FWD

Go Up 1 Level

Acquisition Process Model

1.1.4.15 Risk Management Framework

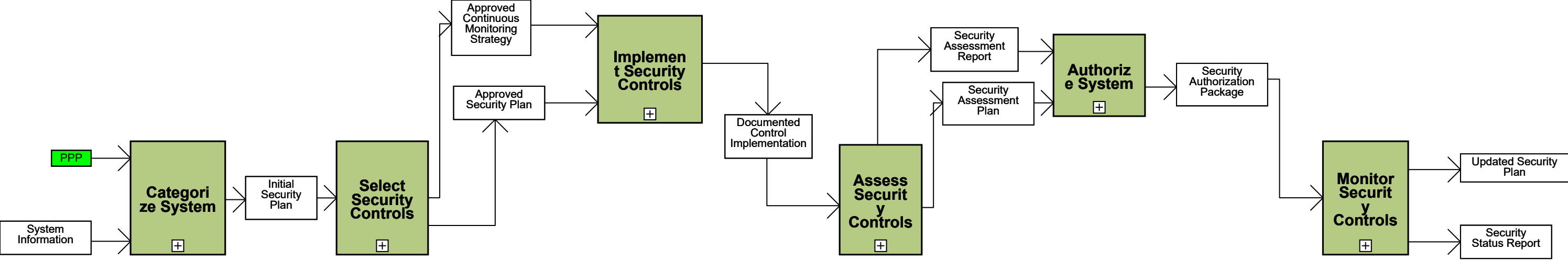

Note: Consistent with Chapter 7 of AFI 17-101, all IT will transition to RMF IAW DoDI 8510.01.

← BACK

FWD →

Go Up 1 Level

Acquisition Process Model

1.1.4.15.1 Categorize System

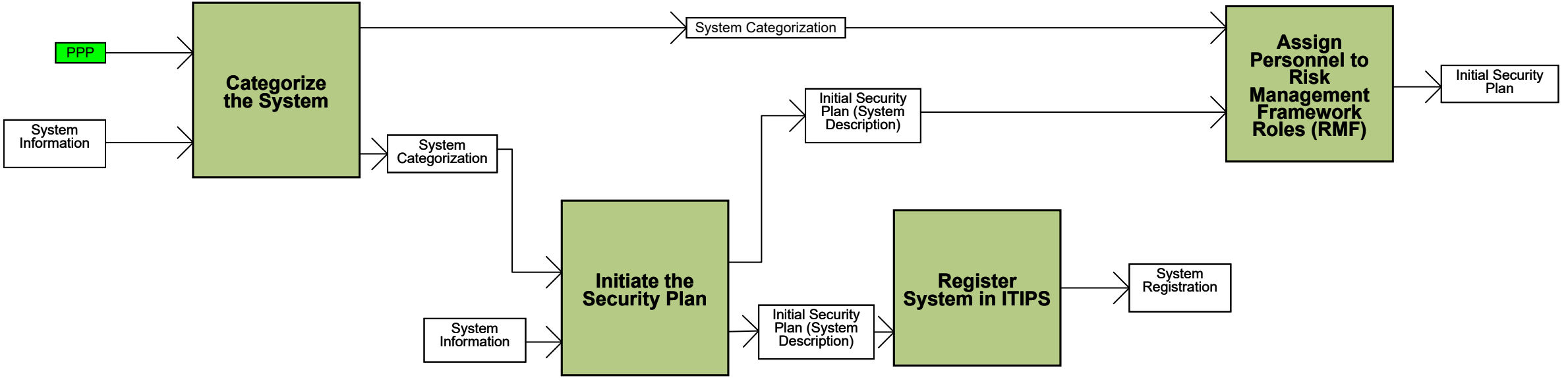

FWD



Acquisition Process Model

1.1.4.15.2 Select Security Controls

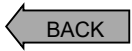
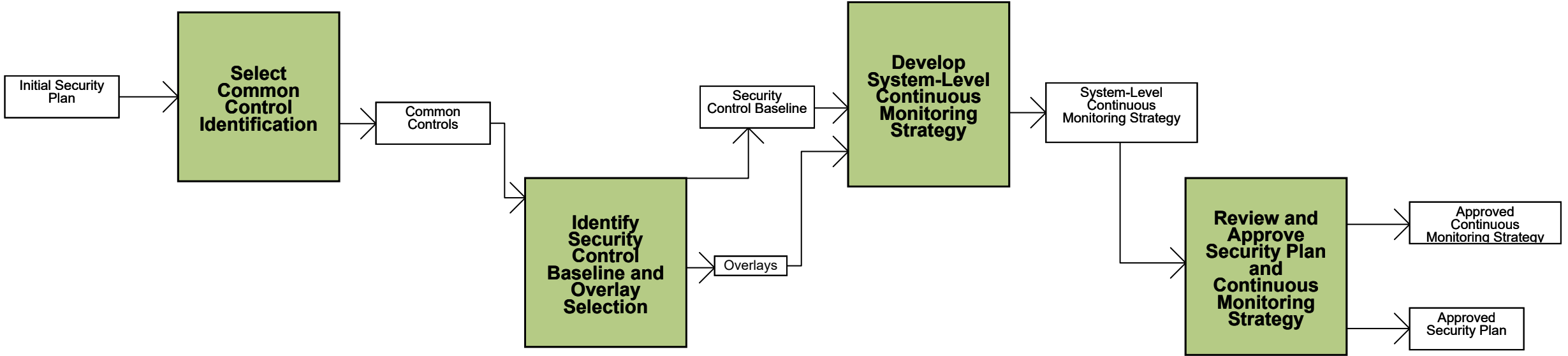

Go Up 1 Level

Acquisition Process Model

1.1.4.15.3 Implement Security Controls

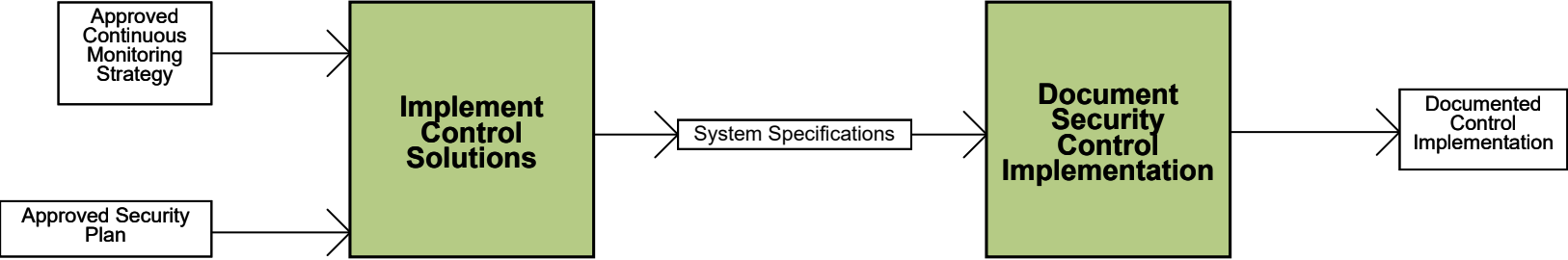

← BACK

FWD →

Go Up 1 Level

Acquisition Process Model

1.1.4.15.4 Assess Security Controls

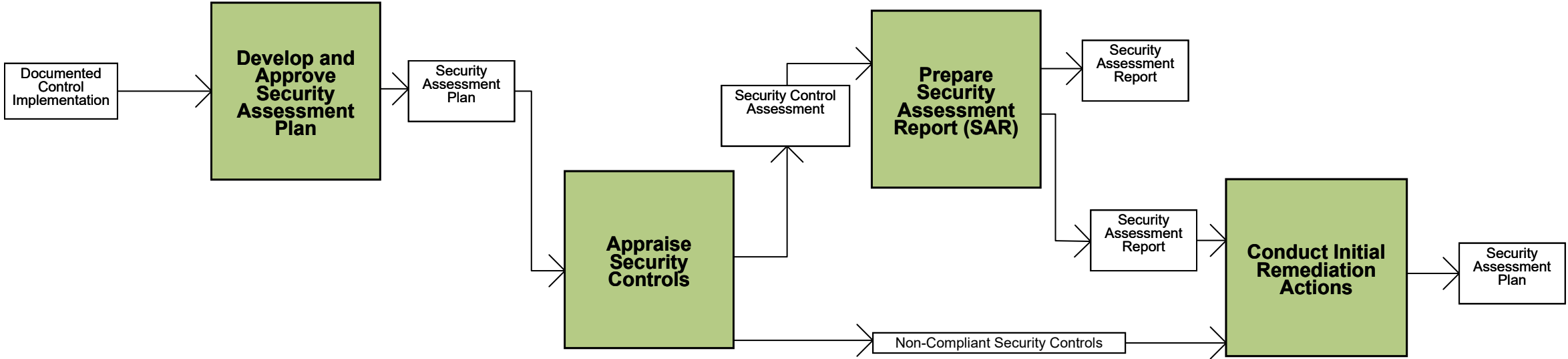

BACK FWD

Go Up 1 Level

Acquisition Process Model

1.1.4.15.5 Authorize System

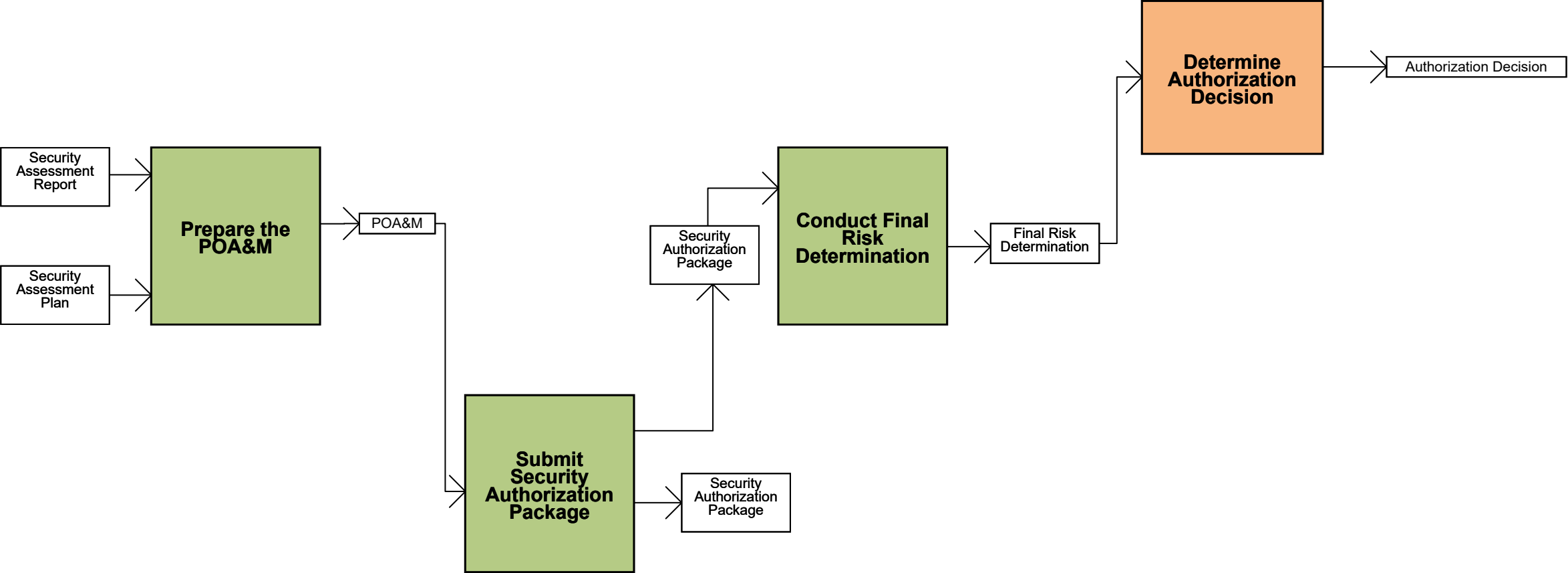

← BACK

FWD →

Go Up 1 Level

Acquisition Process Model

1.1.4.15.6 Monitor Security Controls

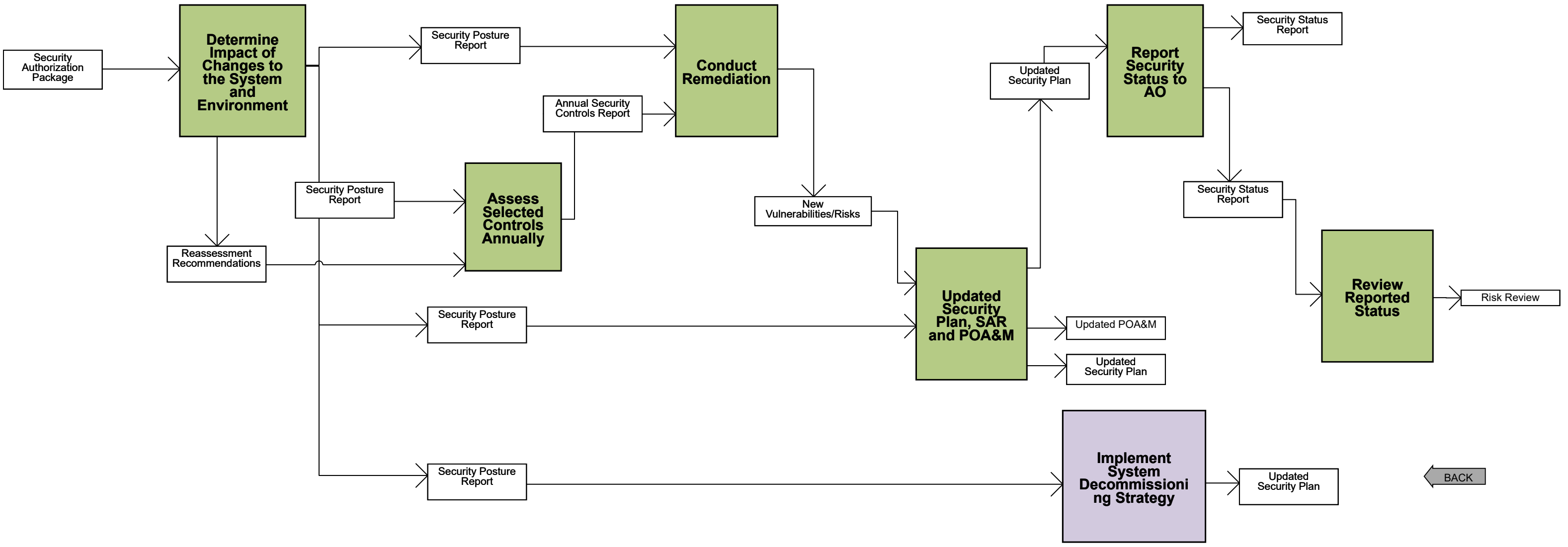

Go Up 1 Level

Acquisition Process Model

1.1.4.17 Independent Logistics Assessment

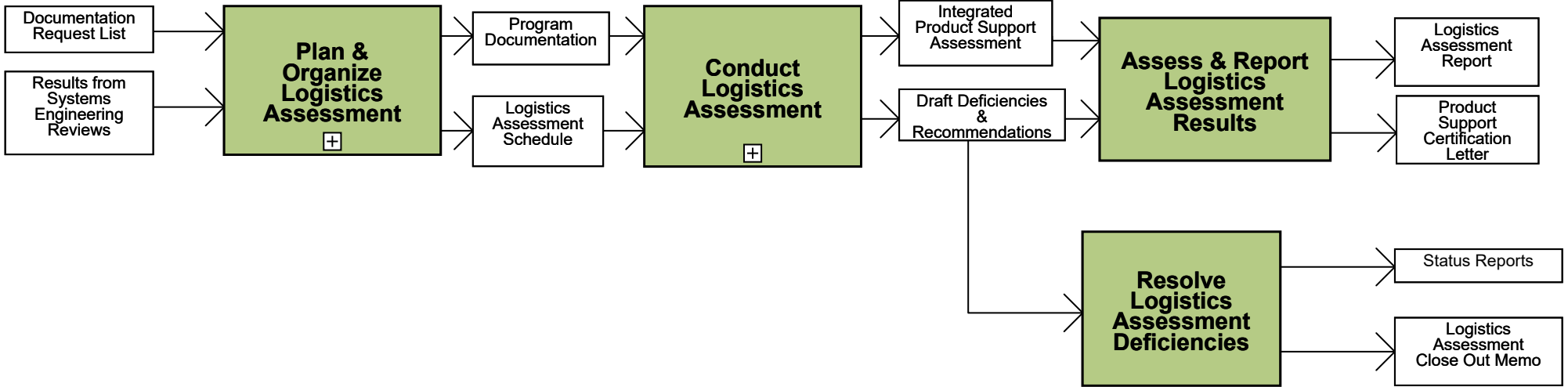

Note: Enclosure 6, Section 5.b of DoDI 5000.02 requires an independent logistics assessment for all ACAT I and II programs prior to key acquisition decision points. Click here to access an active link to the instruction.

← BACK FWD →

Go Up 1 Level

Acquisition Process Model

1.1.4.17.1 Plan and Organize Logistics Assessment

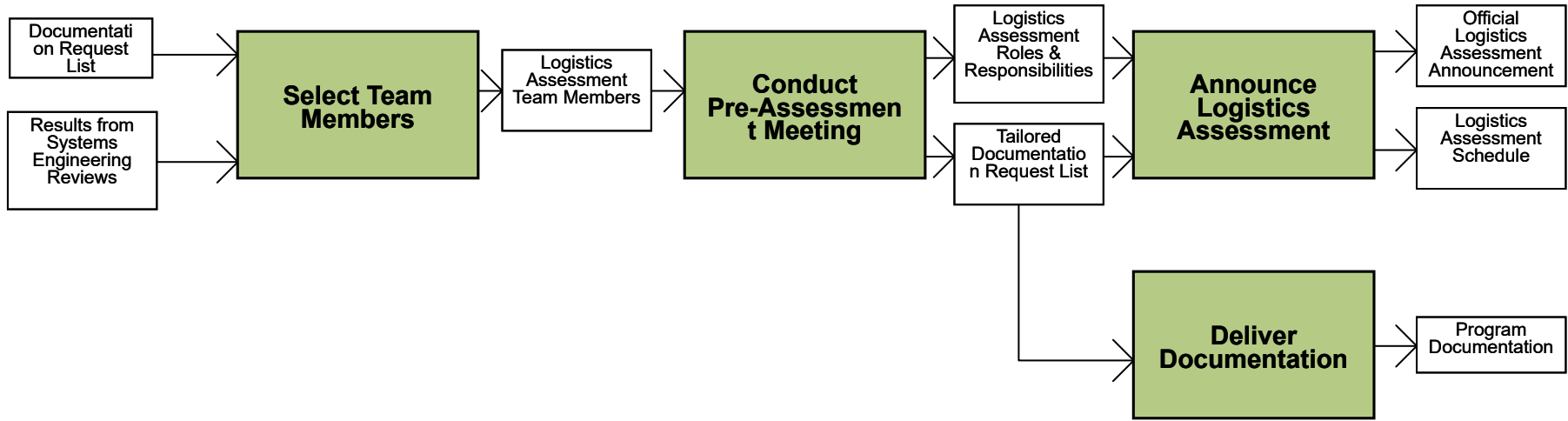

FWD

Go Up 1 Level

Acquisition Process Model

1.1.4.17.2 Conduct Logistics Assessment

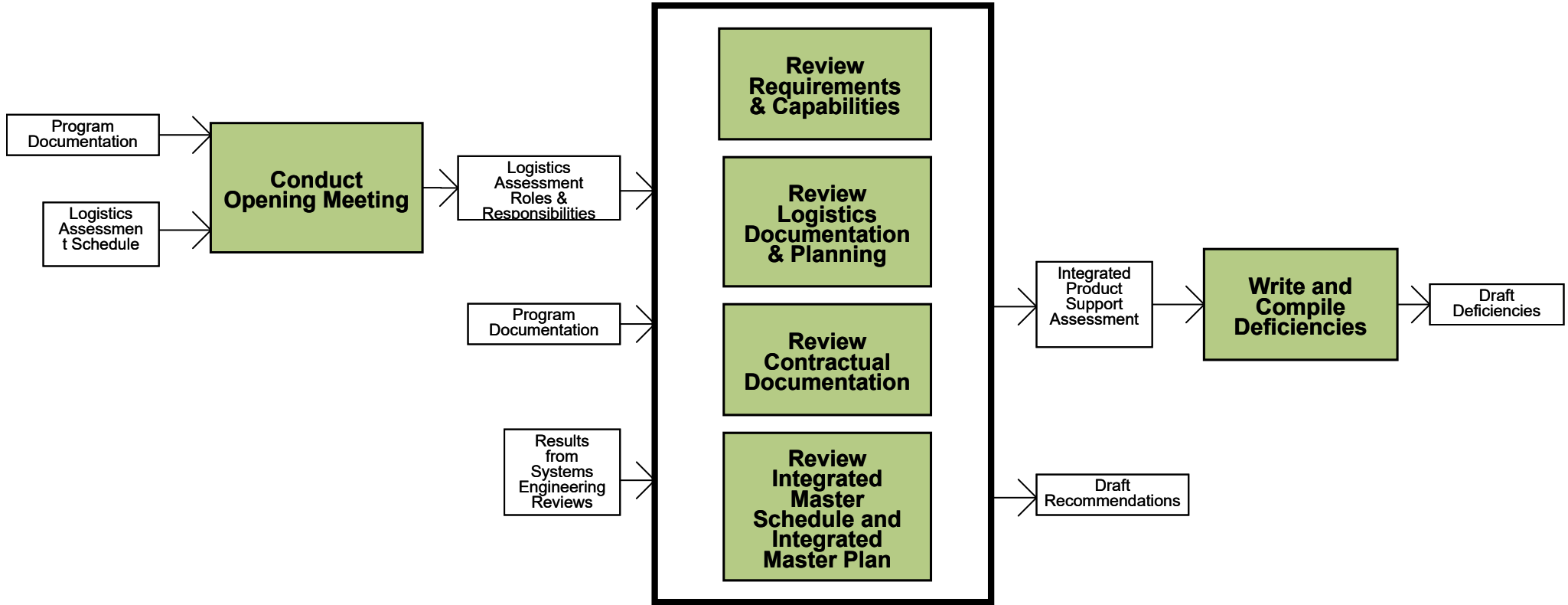

← BACK

Go Up 1 Level

Acquisition Process Model

1.1.4.18 External Technical Assessment

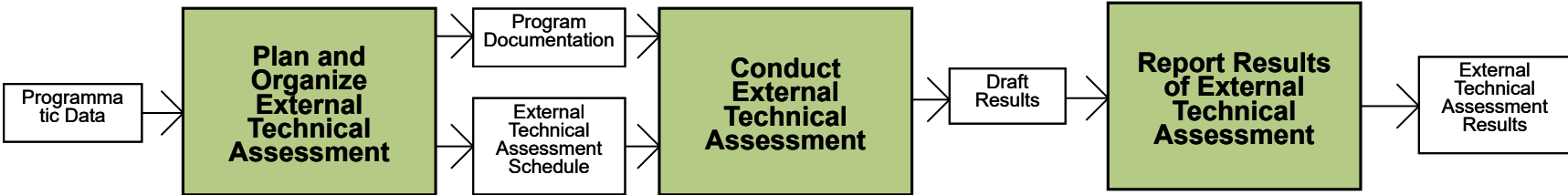

← BACK FWD →

Go Up 1 Level

Acquisition Process Model

1.1.4.19 Logistics Health Assessment

AFLCMC Standard Processes

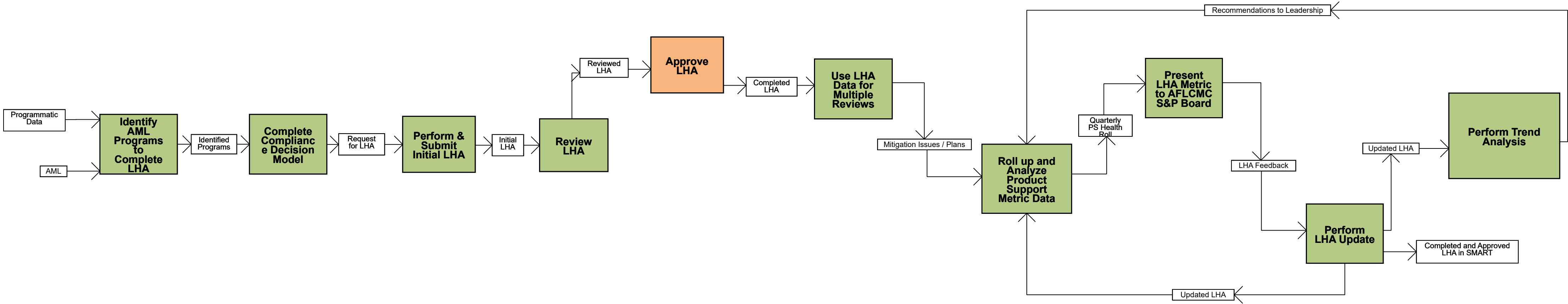

BACK

FWD

Go Up 1 Level

Acquisition Process Model

1.1.4.2 Critical Design Review (CDR)

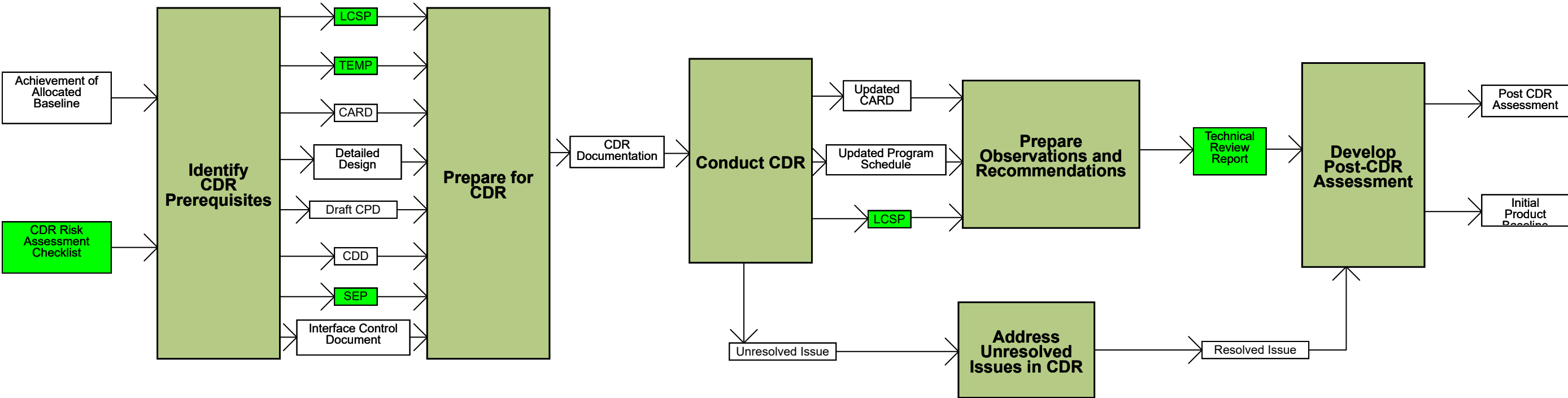

BACK

FWD

Go Up 1 Level

Acquisition Process Model

1.1.4.20 Program Sufficiency Review

AFLCMC
Standard
Processes

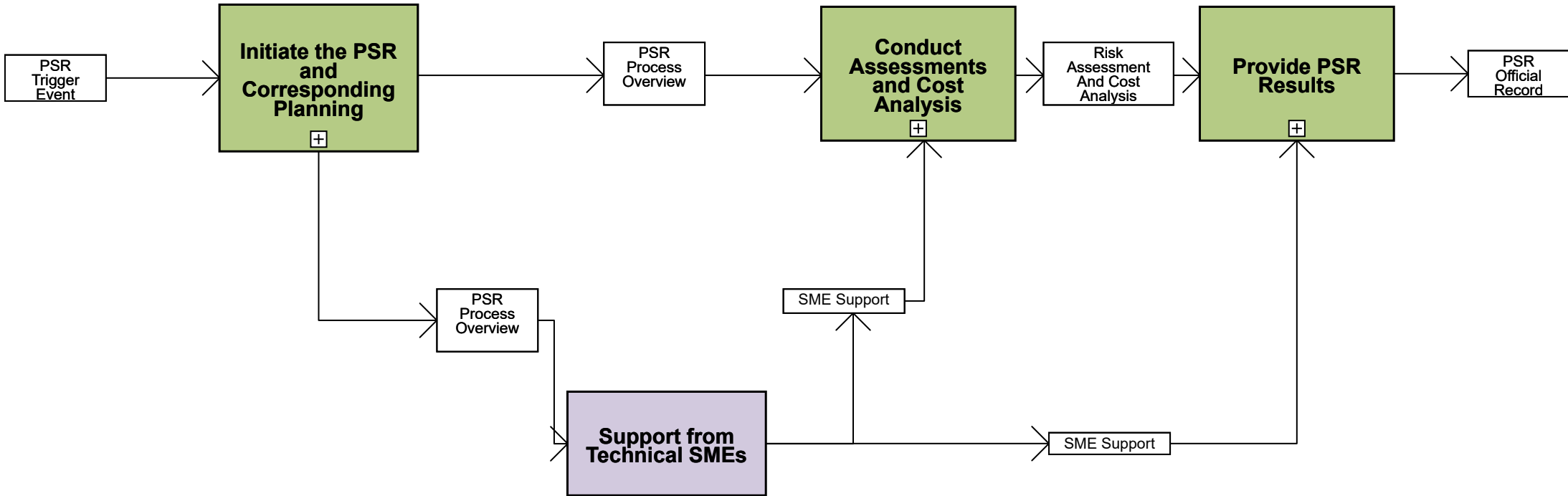

Note: This is an
AFLCMC
Process Guide.

← BACK

Go Up 1 Level

Acquisition Process Model

1.1.4.20.1 Initiate the PSR and Corresponding Planning

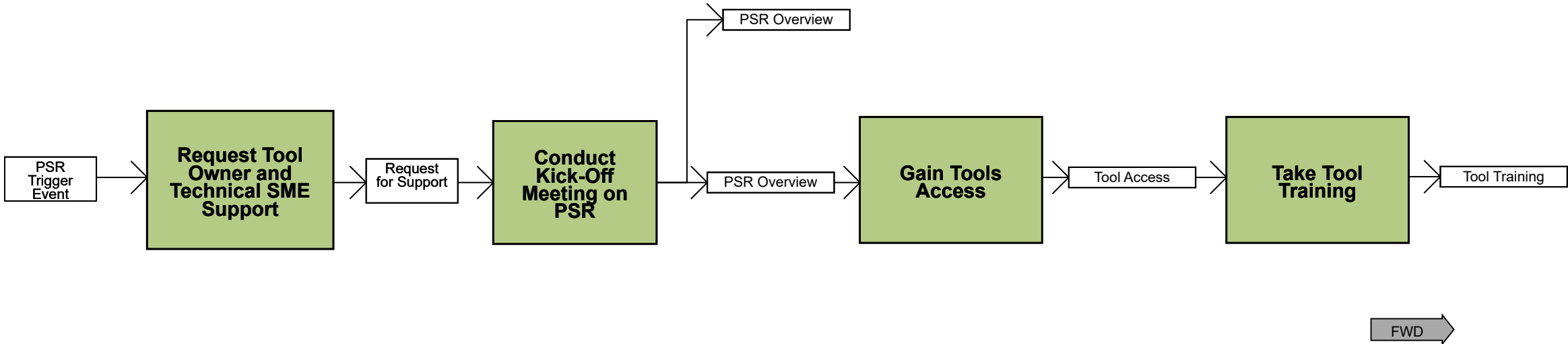

Go Up 1 Level

Acquisition Process Model

1.1.4.20.2 Conduct Assessments and Cost Analysis

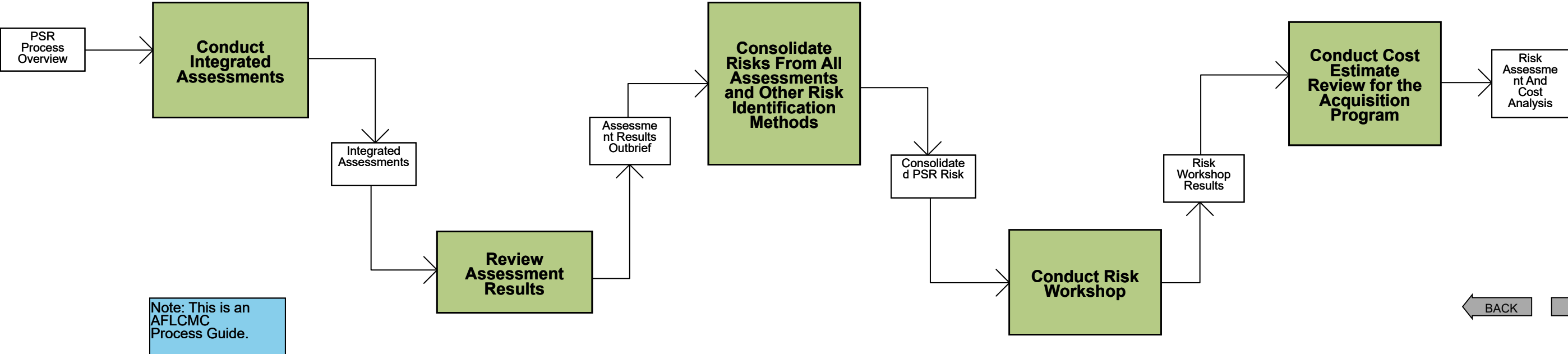

Go Up 1 Level

Acquisition Process Model

1.1.4.20.3 Provide PSR Results

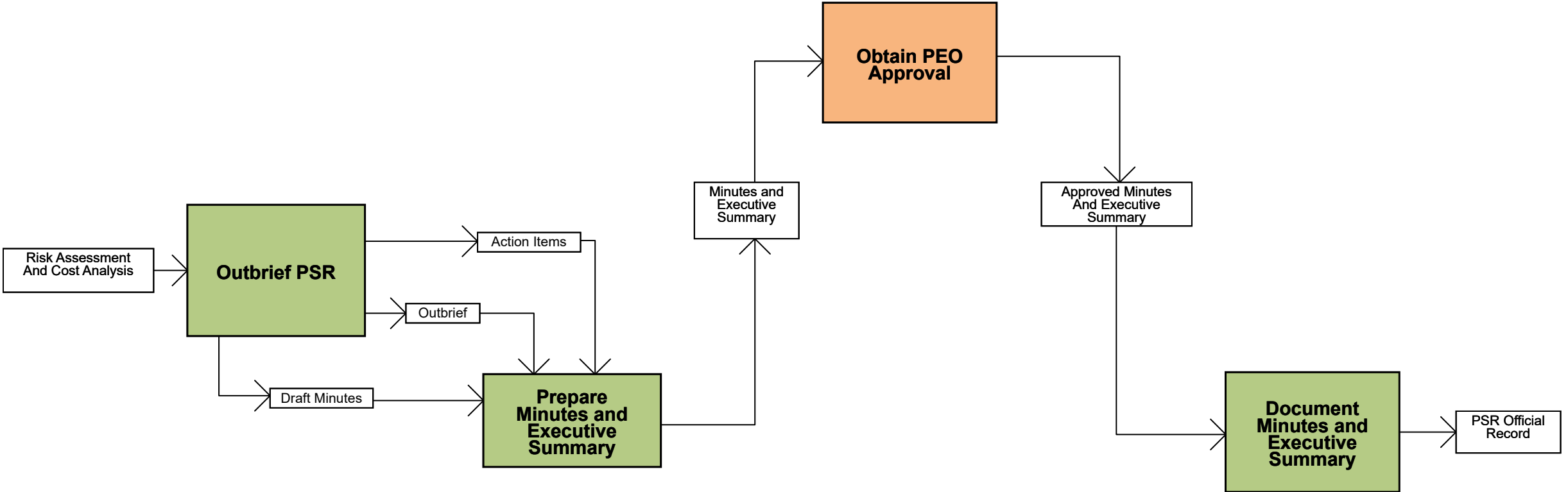

Note: This is an AFLCMC Process Guide.

← BACK

Acquisition Process Model

1.1.4.3 Production Readiness Review (PRR)

Go Up 1 Level

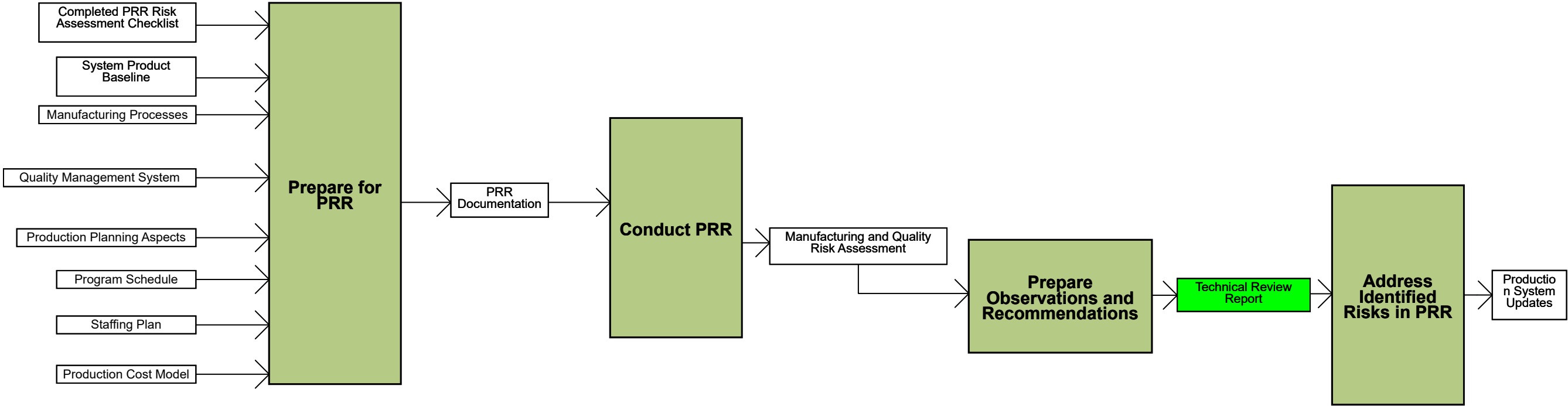

Note: Process Triggers
 EMD Phase
 - Upcoming Technical Review

P&D Phase
 - EMD Manufacturing or Material Design Changes
 - Production Phase Manufacturing Or Material Design Changes
 - Production Start-Up
 - Production Re-Start After Significant Shutdown
 - Production Start-Up With New Contractor
 - Manufacturing Site Relocation

← BACK
FWD →

Acquisition Process Model

1.1.4.4 Test Readiness Review (TRR)

Go Up 1 Level

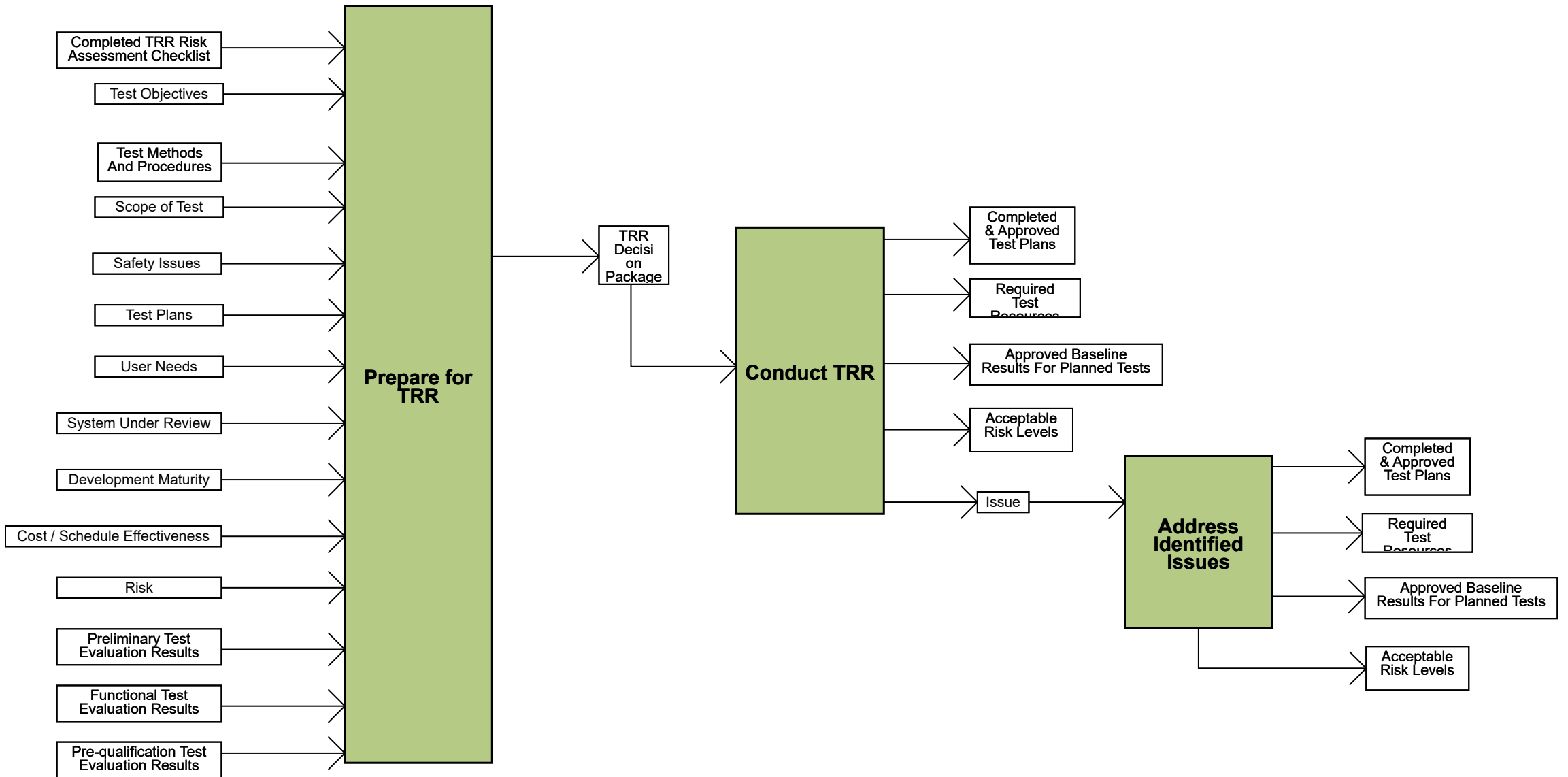

BACK

FWD

Go Up 1 Level

Acquisition Process Model

1.1.4.5 System Functional Review (SFR)

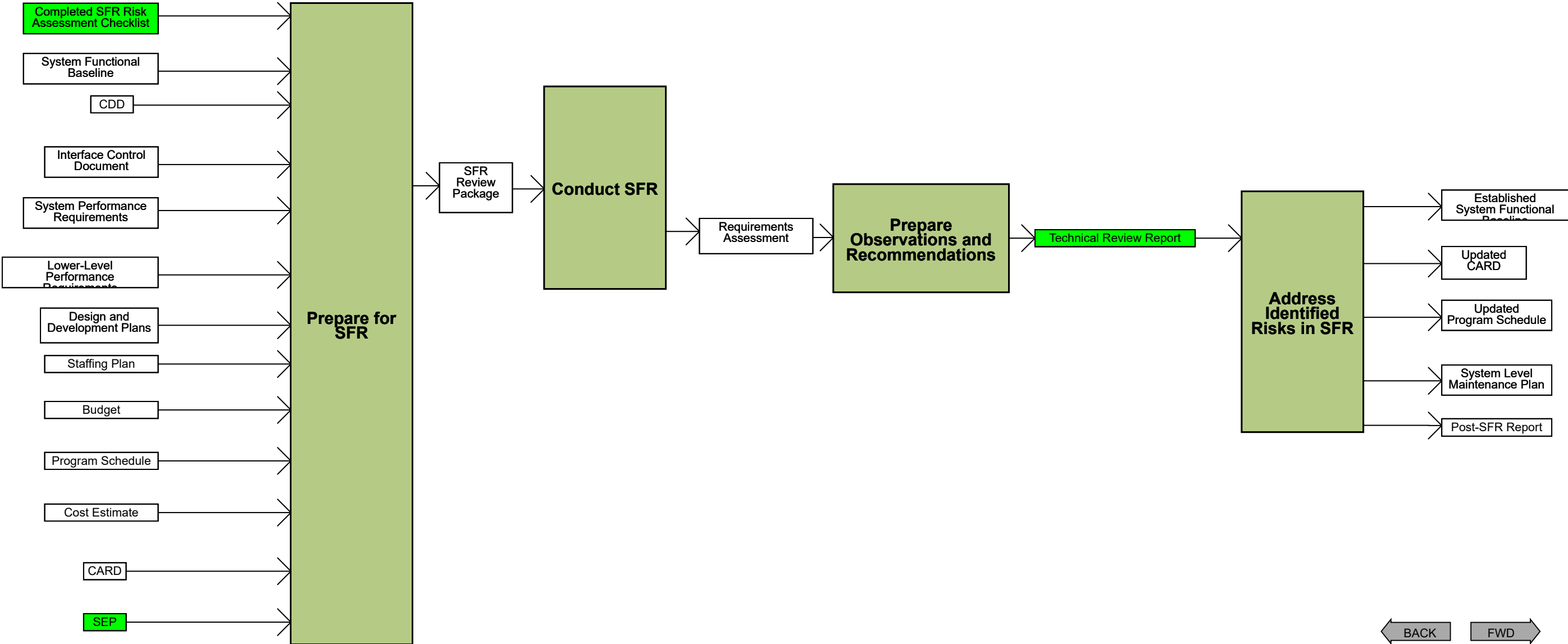

BACK

FWD

Go Up 1 Level

Acquisition Process Model

1.1.4.6 System Requirements Review (SRR)

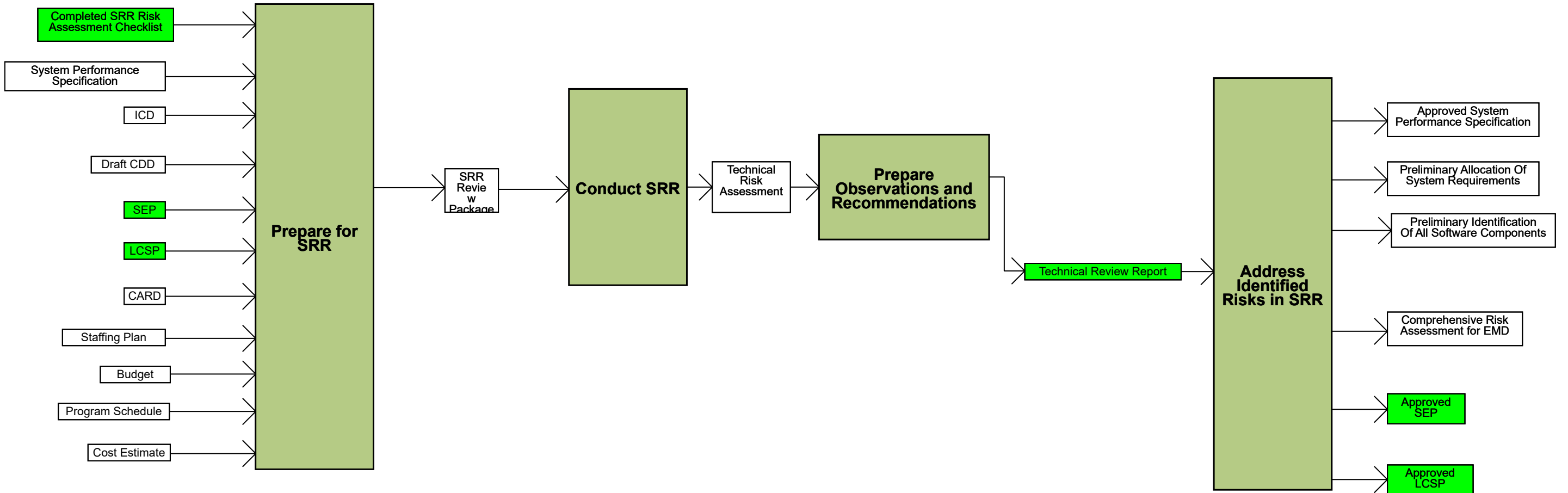

← BACK

FWD →

Go Up 1 Level

Acquisition Process Model

1.1.4.7 Manufacturing Readiness Assessment (MRA)

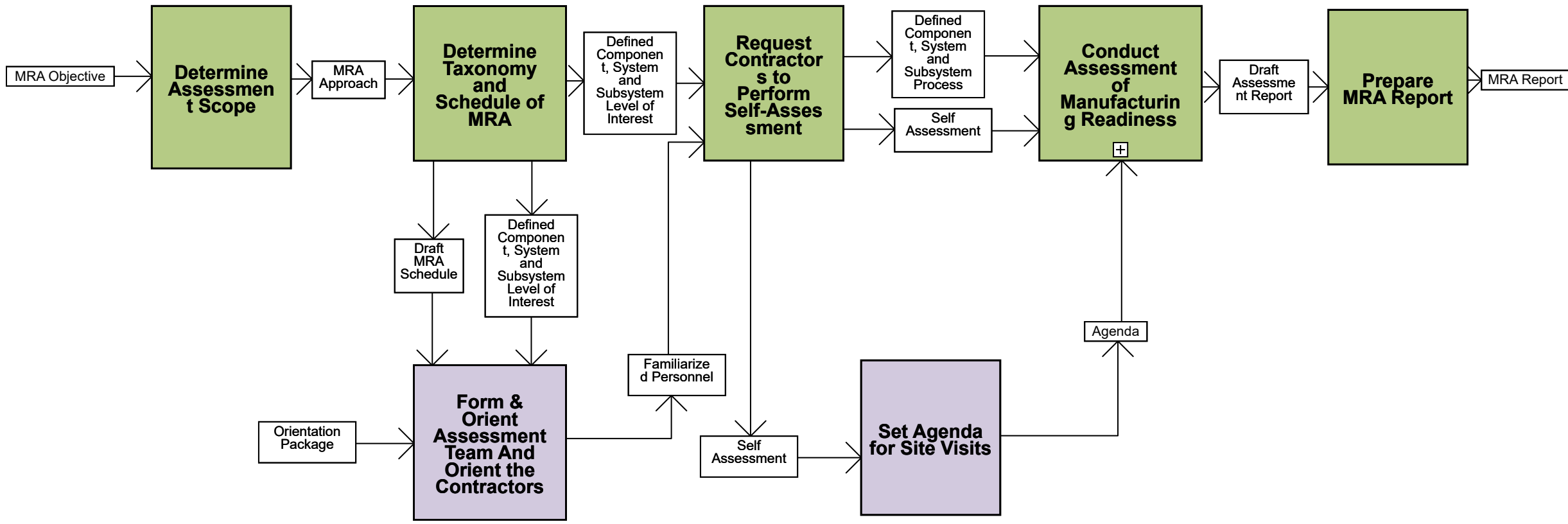

← BACK

FWD →

Acquisition Process Model

1.1.4.7.6 Conduct the Assessment of Manufacturing Readiness

Go Up 1 Level

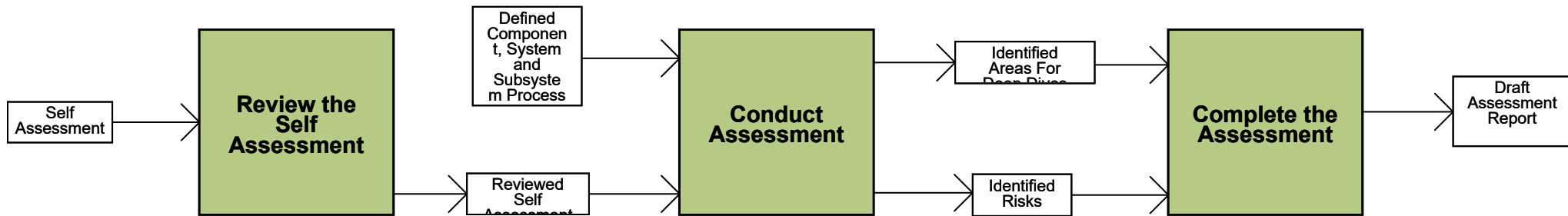

Go Up 1 Level

Acquisition Process Model

1.1.4.8 Functional Configuration Audit (FCA)

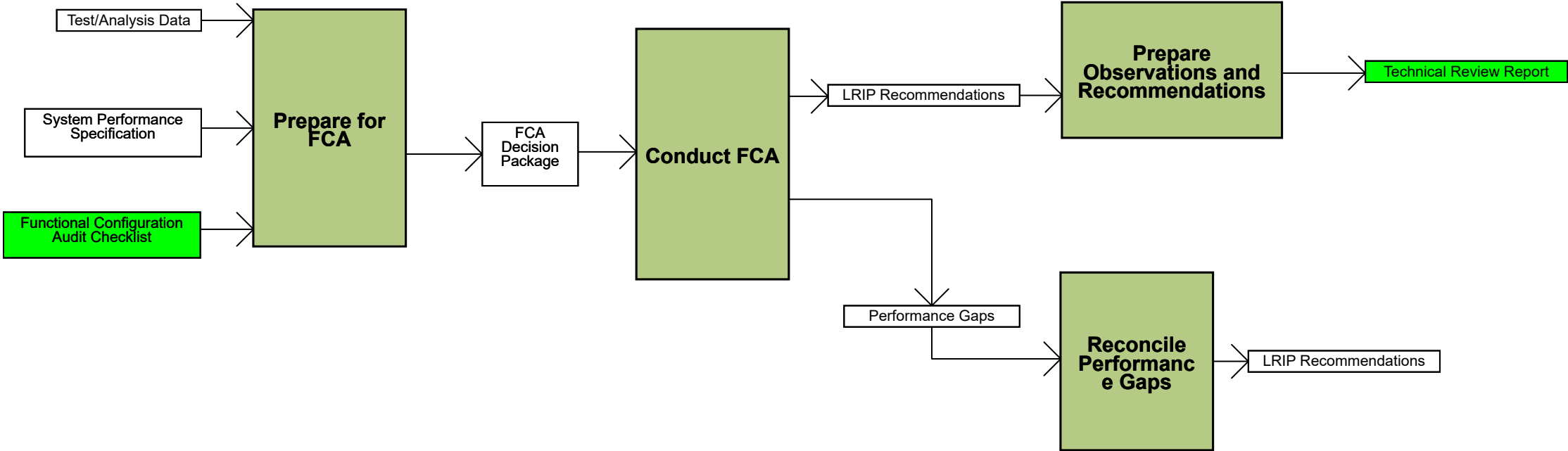

← BACK

FWD →



Acquisition Process Model

1.1.4.9 Physical Configuration Audit (PCA)

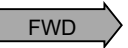
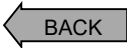
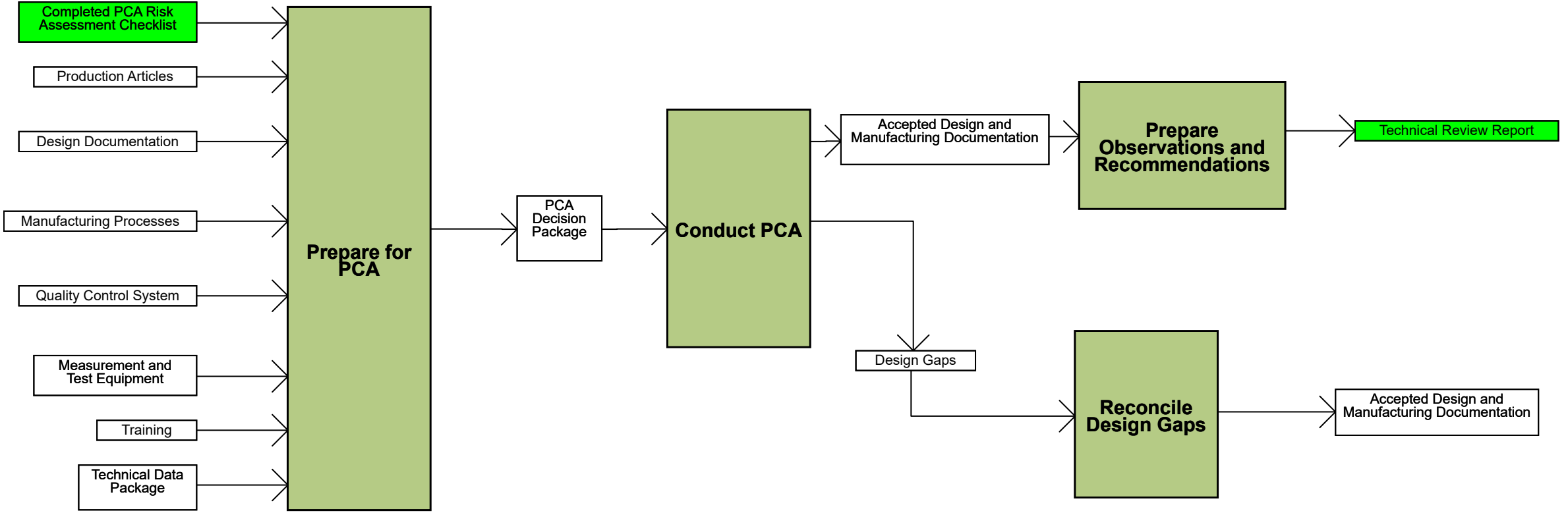

Go Up 1 Level

Acquisition Process Model

1.1.5 Execute Acquisition Management Integration

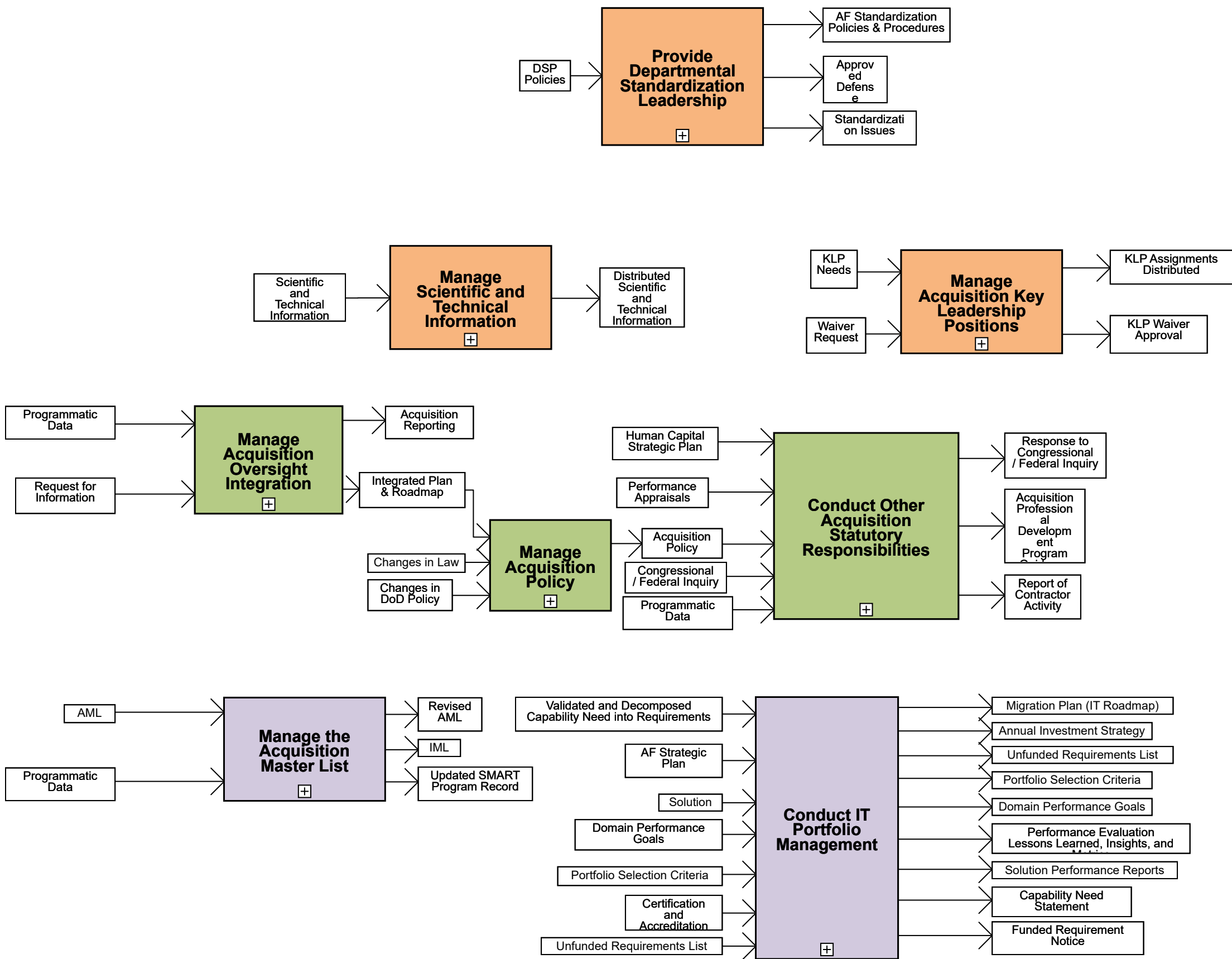

← BACK



Acquisition Process Model

1.1.5.1 Manage Acquisition Oversight Integration

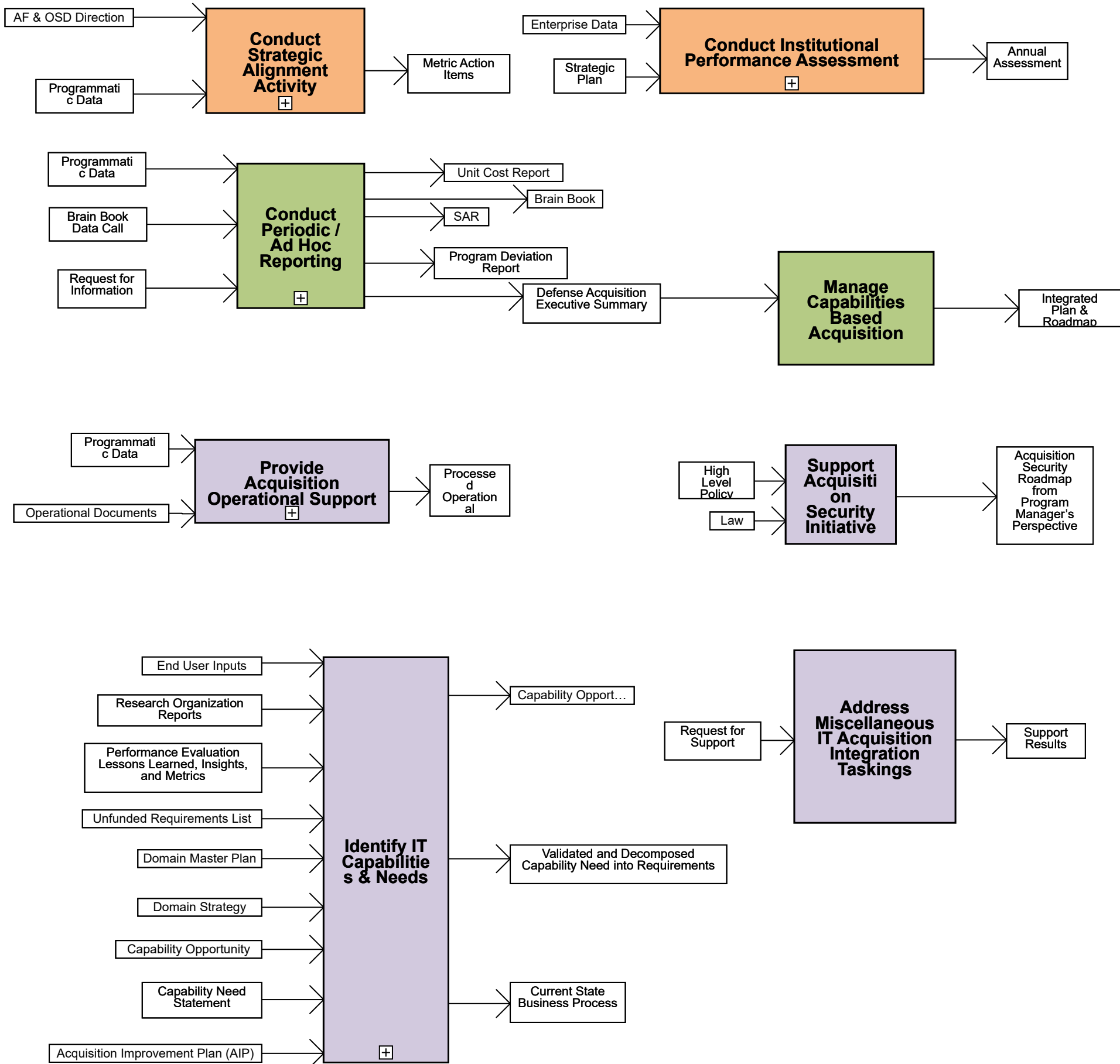

Go Up 1 Level

Acquisition Process Model

1.1.5.1.1 Conduct Periodic/Ad Hoc Reporting

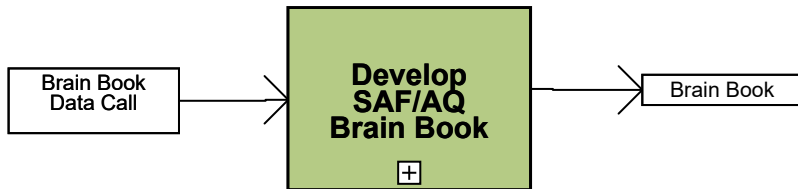

Acquisition Process Model

1.1.5.1.1.1 Develop SAF/AQ Brain Book

Go Up 1 Level

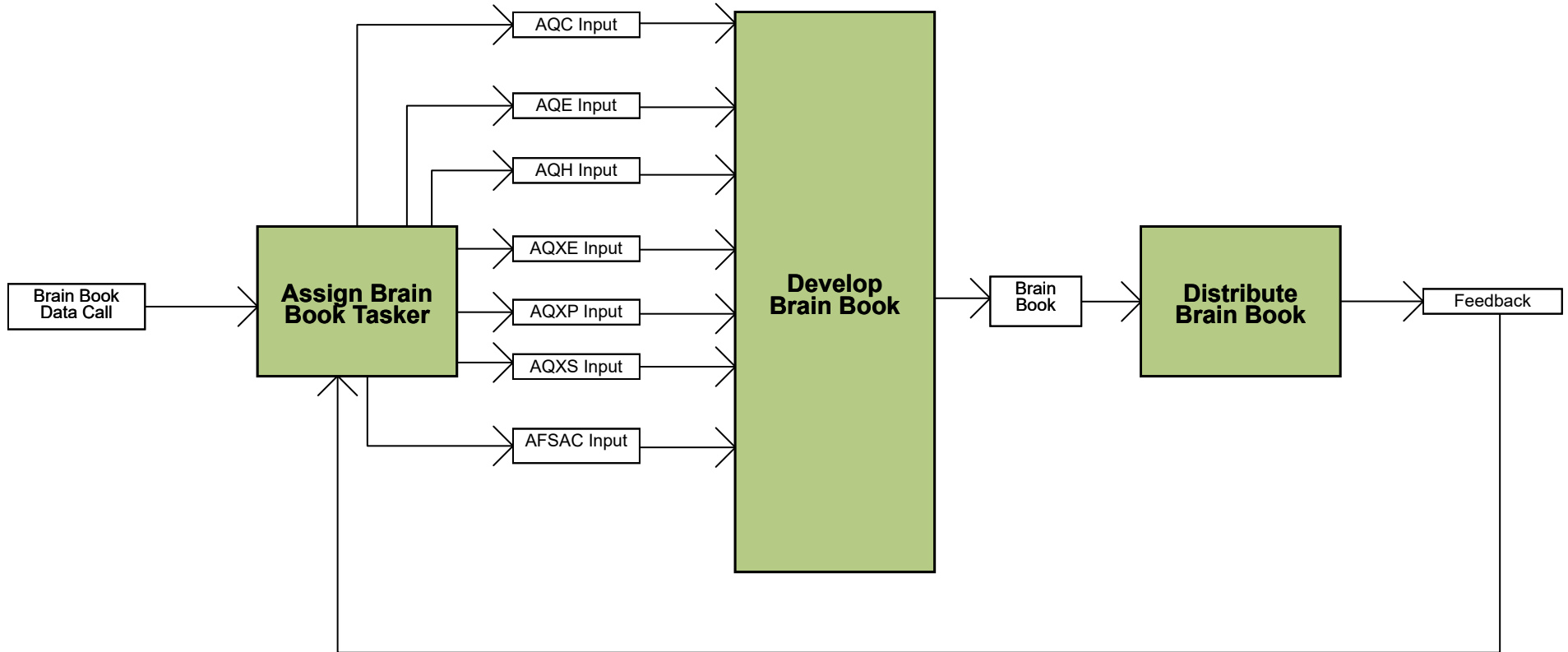

Go Up 1 Level

Acquisition Process Model

1.1.5.1.2 Provide Acquisition Operational Support

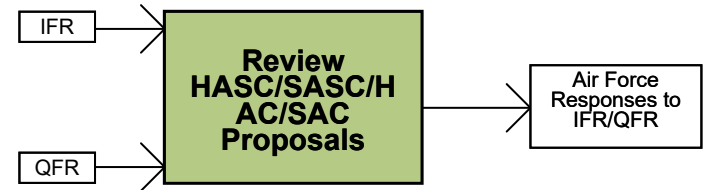
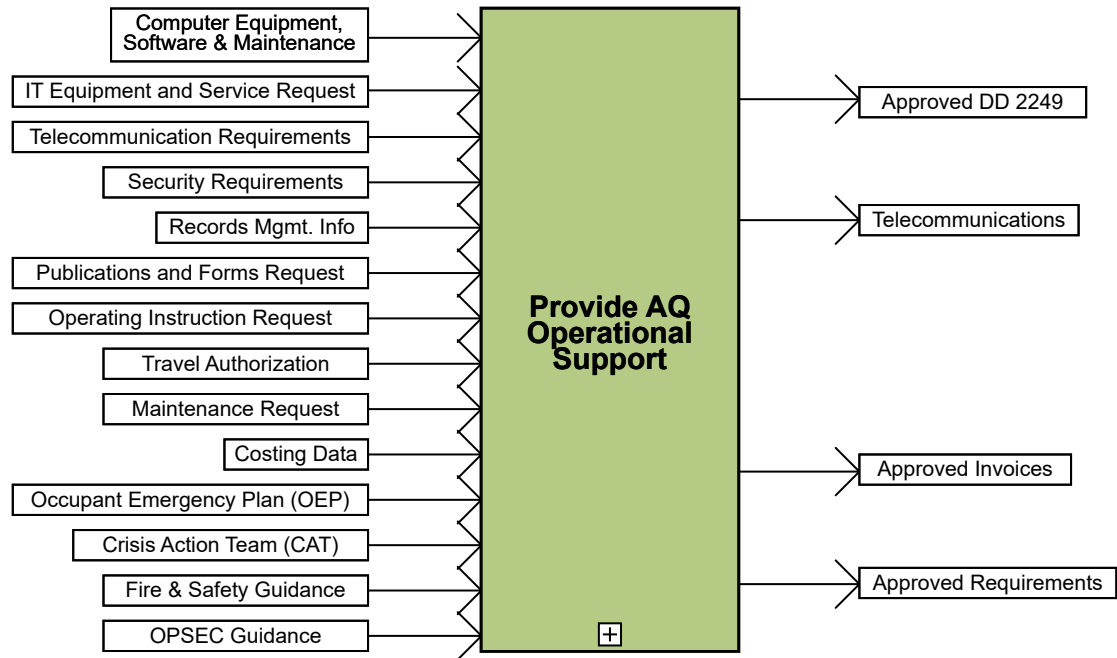
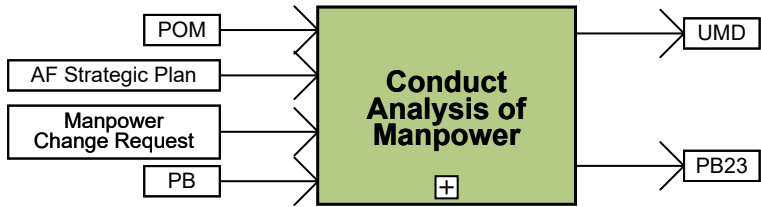

FWD



Acquisition Process Model

1.1.5.1.2.1 Analysis of Manpower

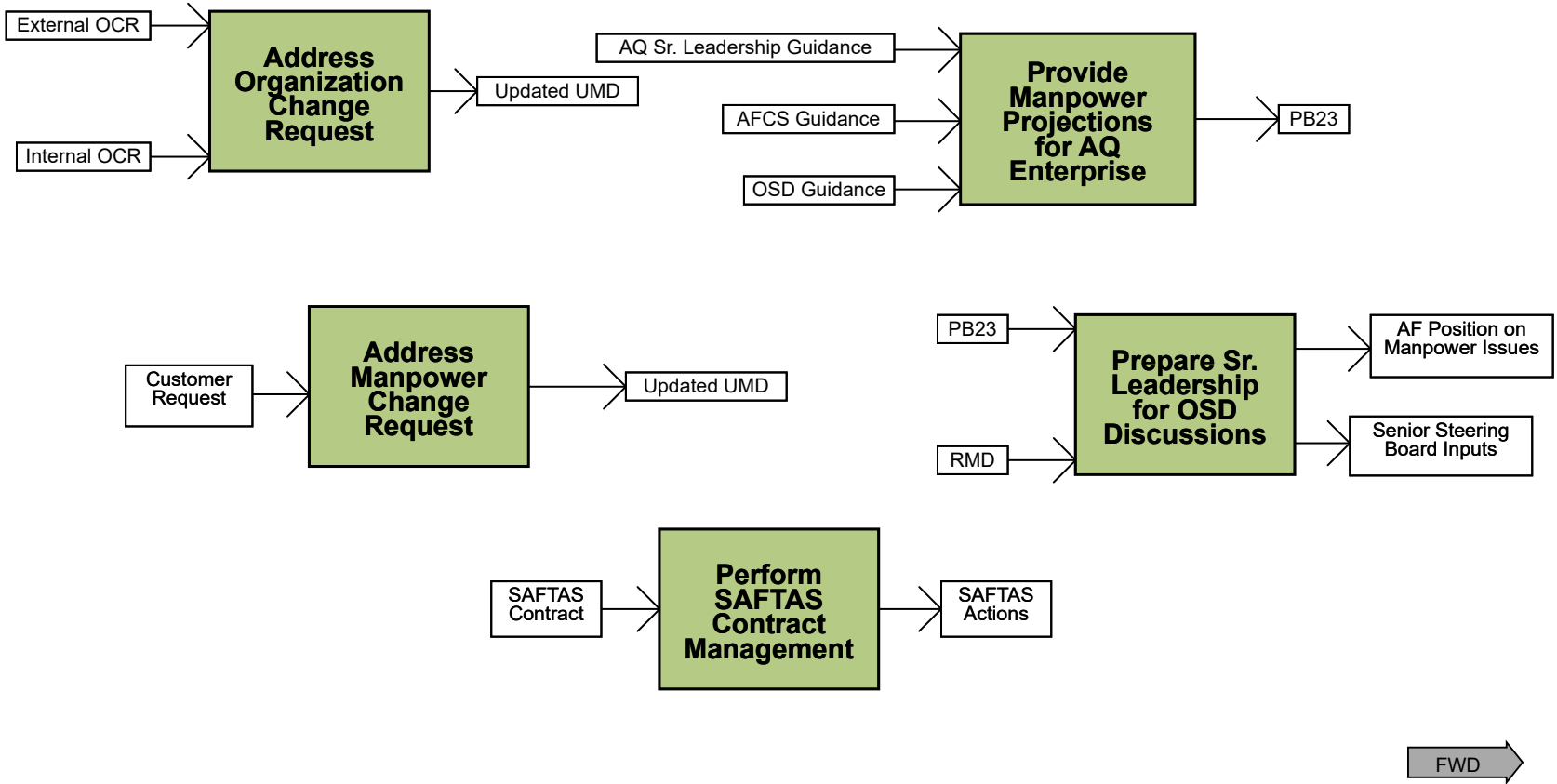

Go Up 1 Level

Acquisition Process Model

1.1.5.1.2.2 AQ Operational Support

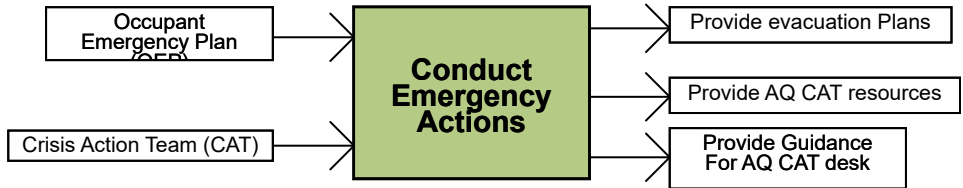
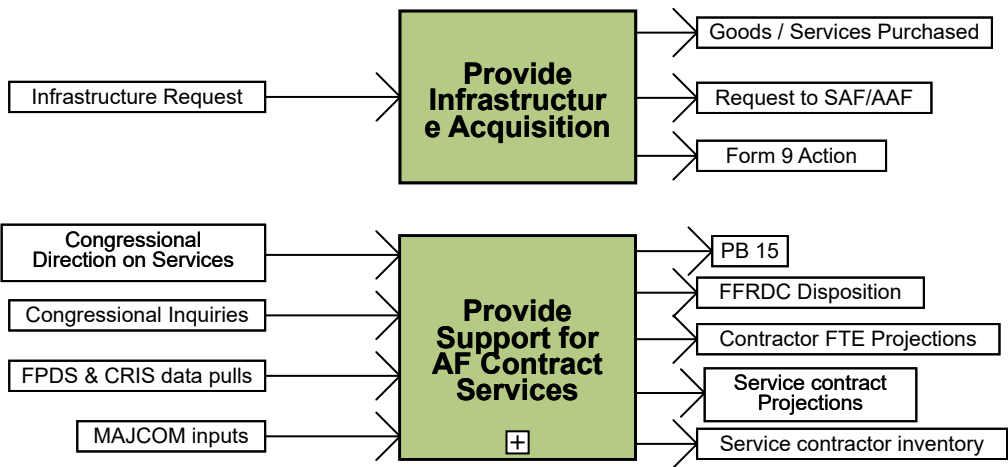
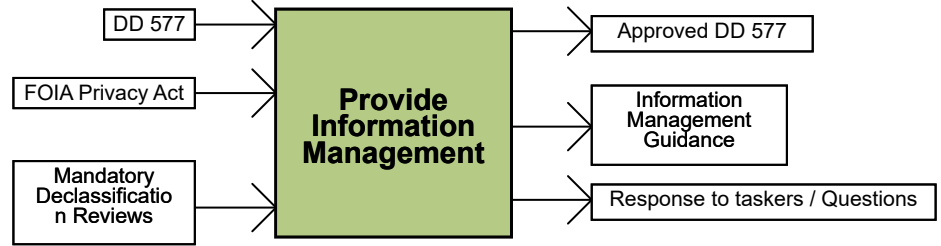
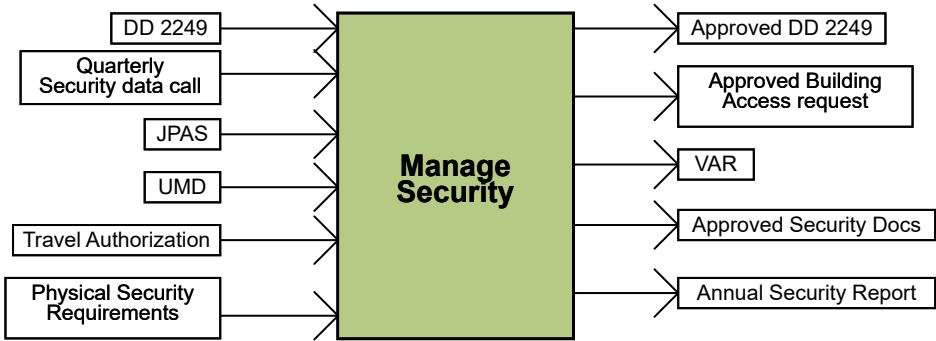

← BACK

Go Up 1 Level

Acquisition Process Model

1.1.5.1.2.2.5 Provide Support for AF Contract Services

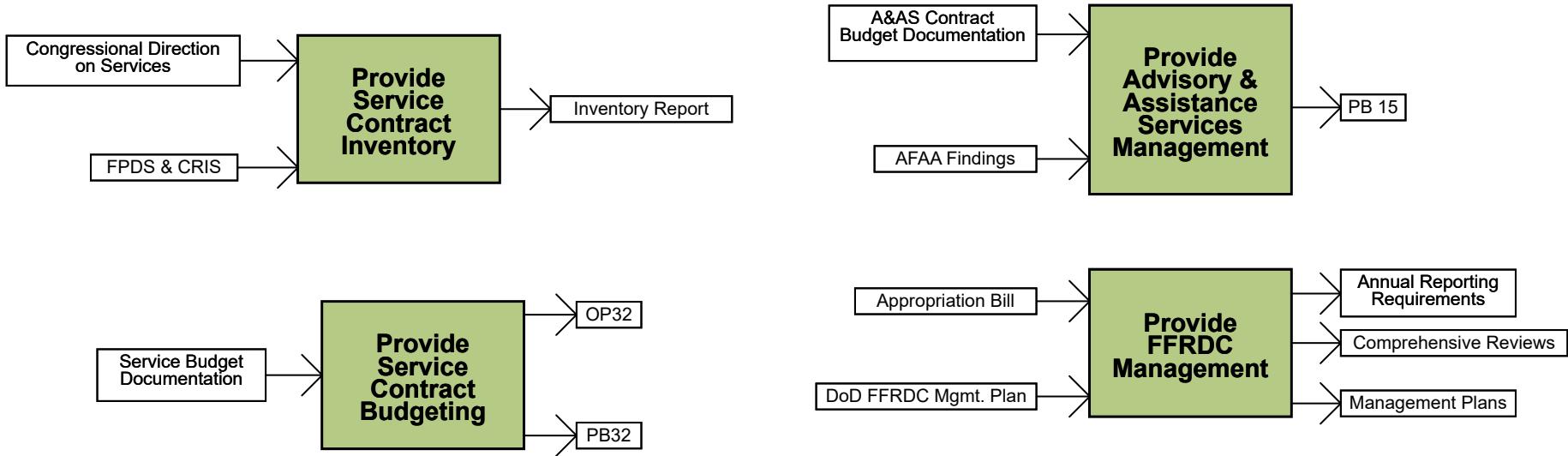

Go Up 1 Level

Acquisition Process Model

1.1.5.1.4 Strategic Alignment Activity

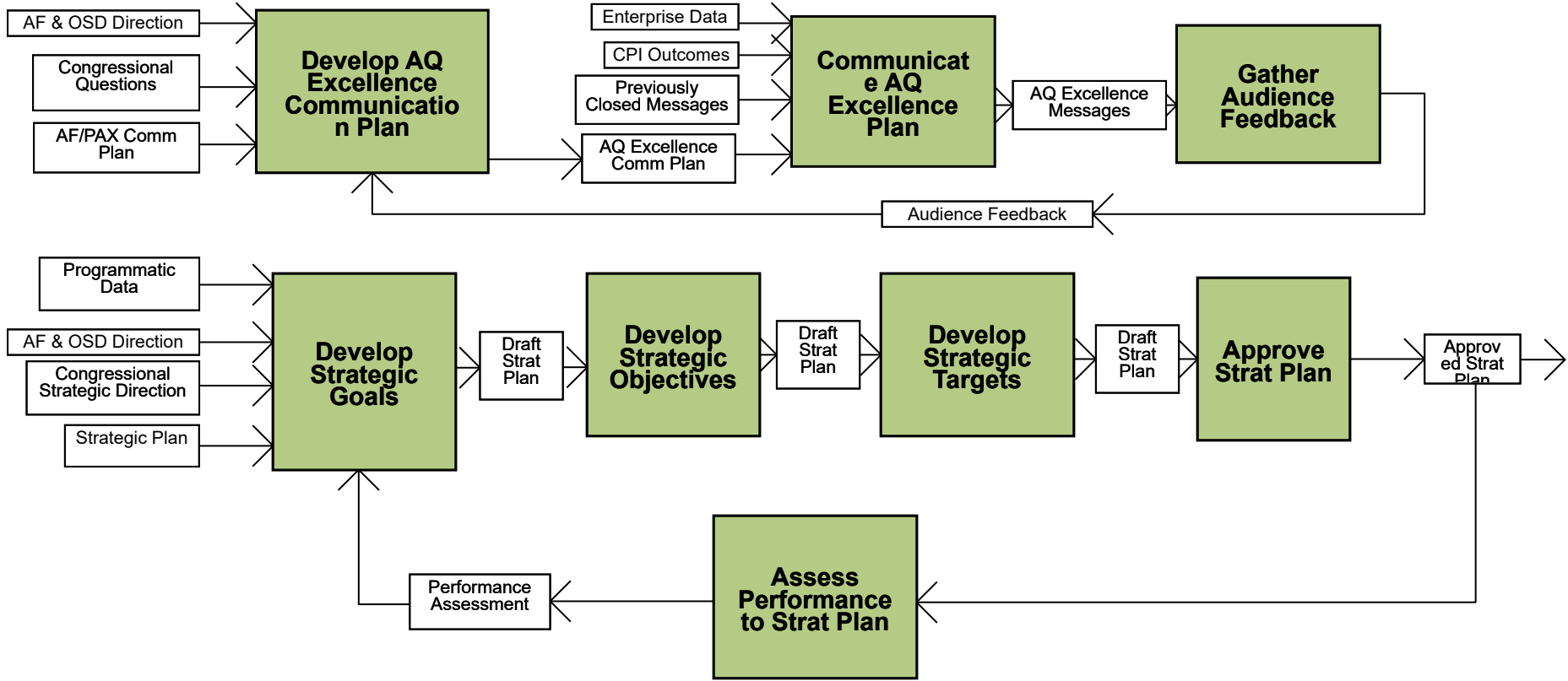

← BACK FWD →



Acquisition Process Model

1.1.5.1.5 Conduct Institutional Performance Assessment

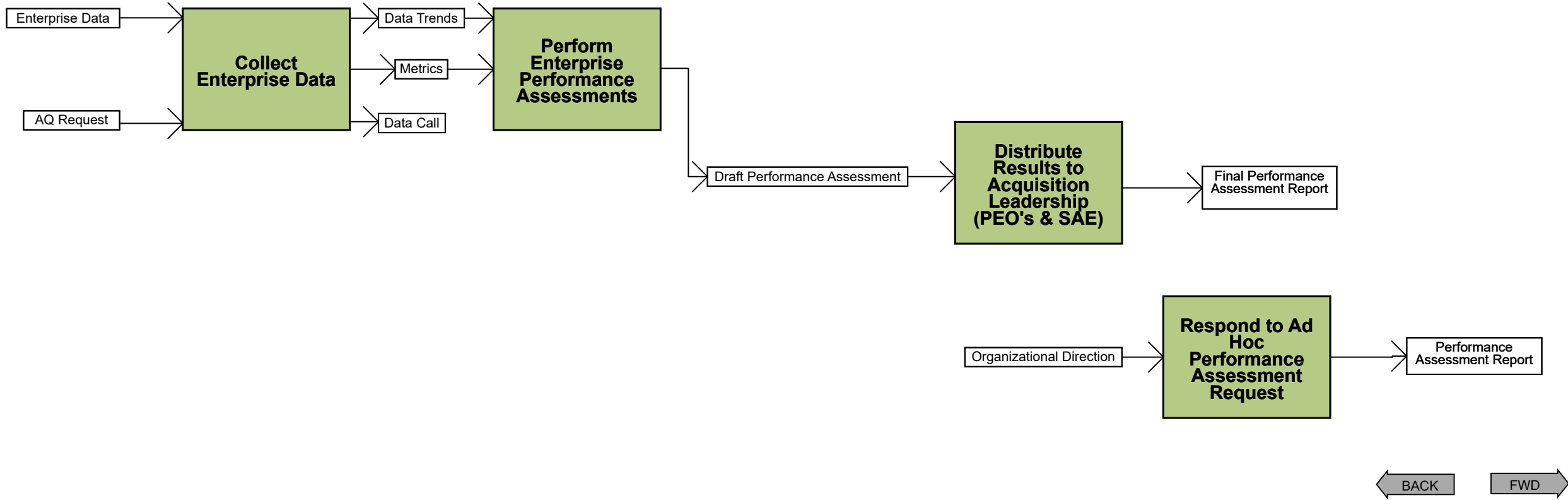

Go Up 1 Level

Acquisition Process Model

1.1.5.1.6 Identify IT Capabilities and Needs

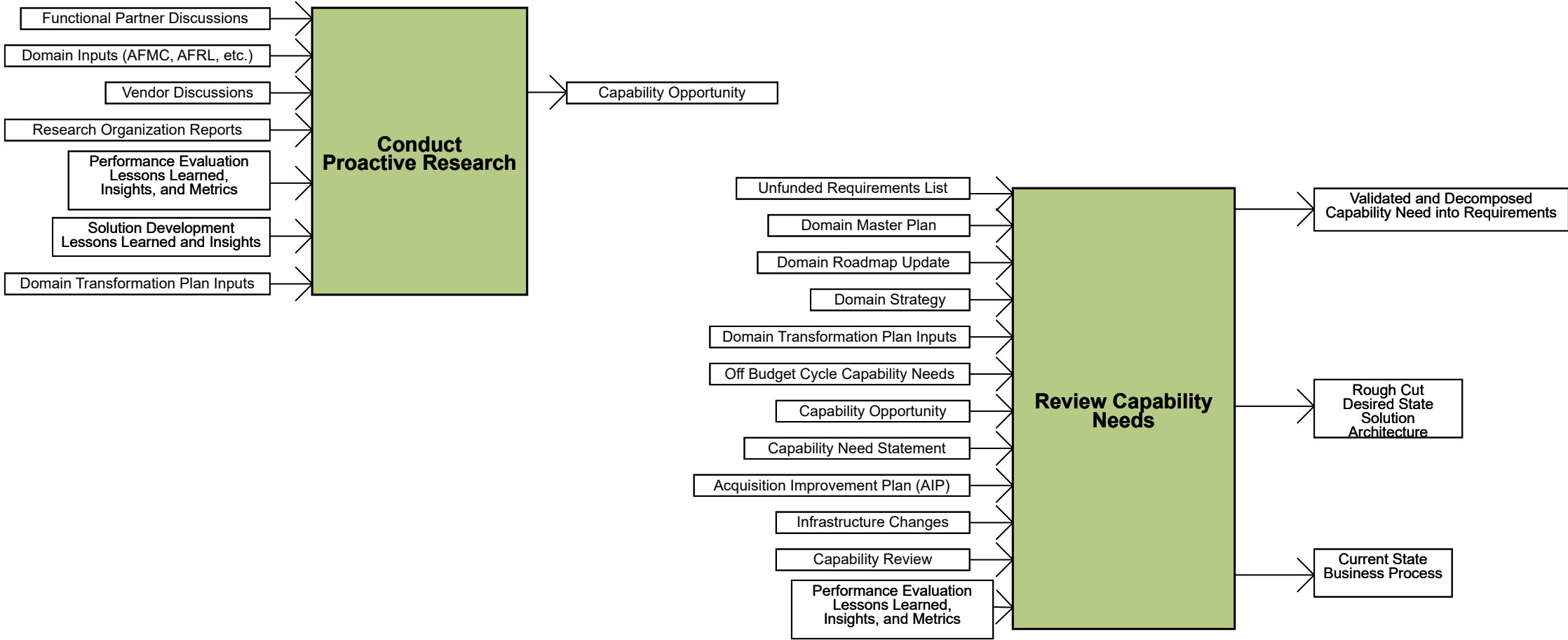

← BACK

Go Up 1 Level

Acquisition Process Model

1.1.5.2 Manage Acquisition Policy

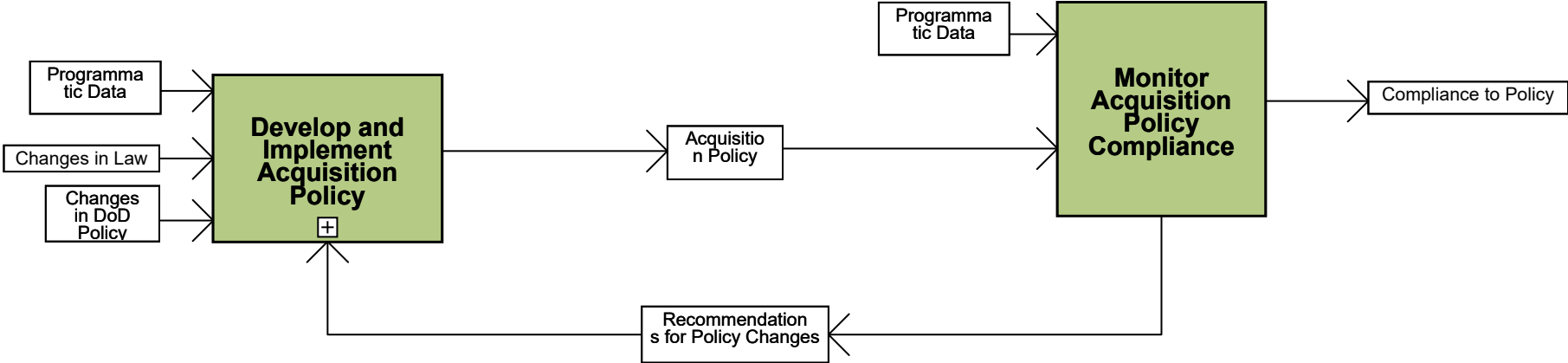

Go Up 1 Level

Acquisition Process Model

1.1.5.2.1 Develop and Implement Acquisition Policy

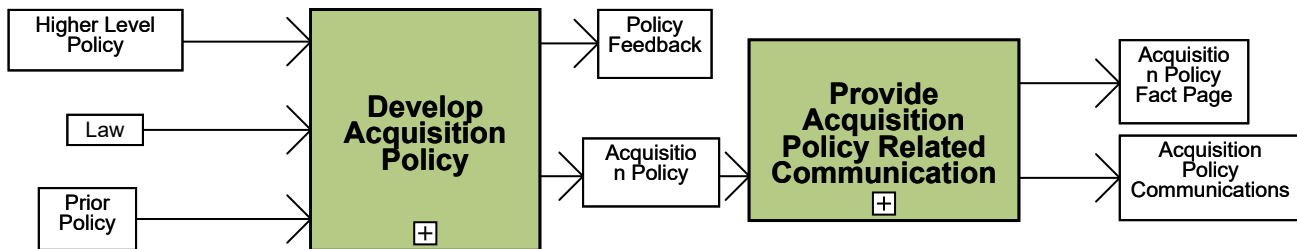

Go Up 1 Level

Acquisition Process Model

1.1.5.2.1.1 Develop Acquisition Policy

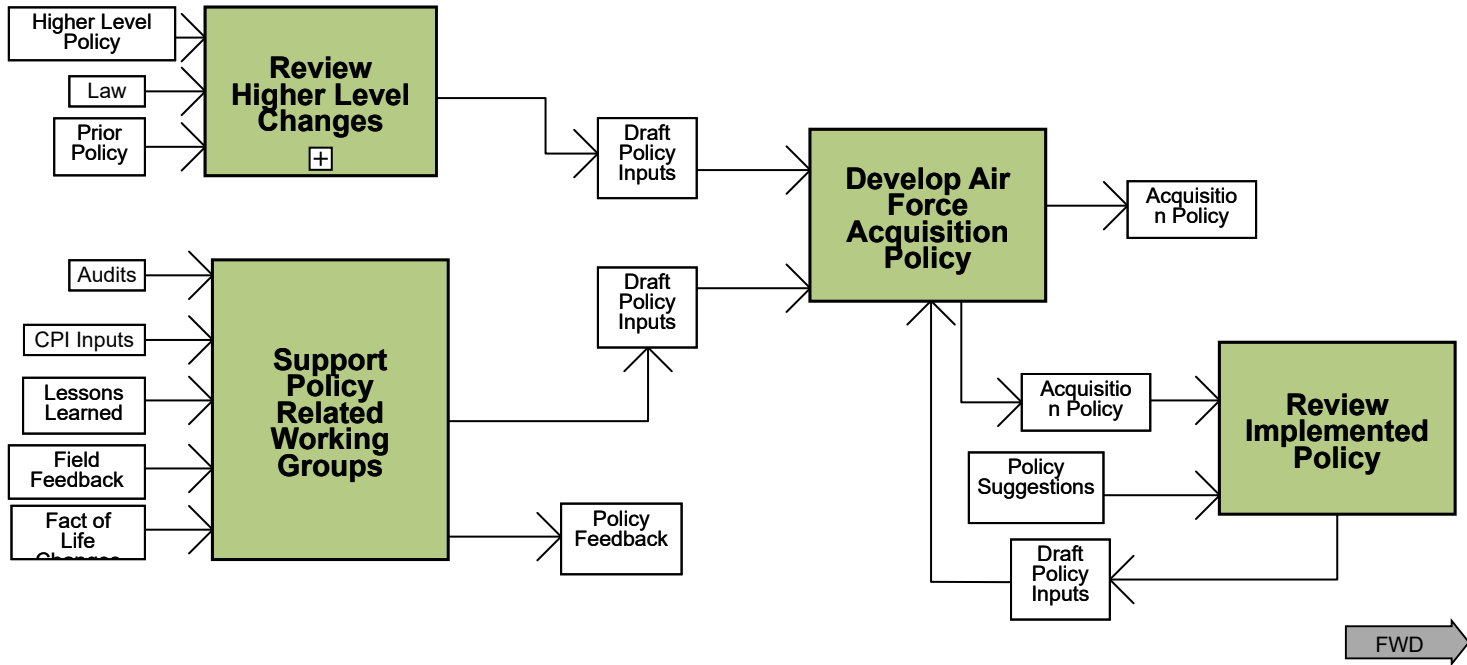

Go Up 1 Level

Acquisition Process Model

1.1.5.2.1.1.1 Review Higher Level Changes

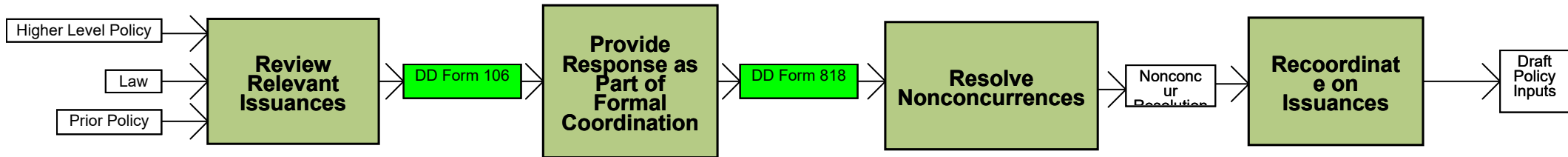



Acquisition Process Model

1.1.5.2.1.2 Provide Acquisition Policy Related Communication

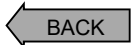

Go Up 1 Level

Acquisition Process Model

1.1.5.3 Conduct Other Acquisition Statutory Responsibilities

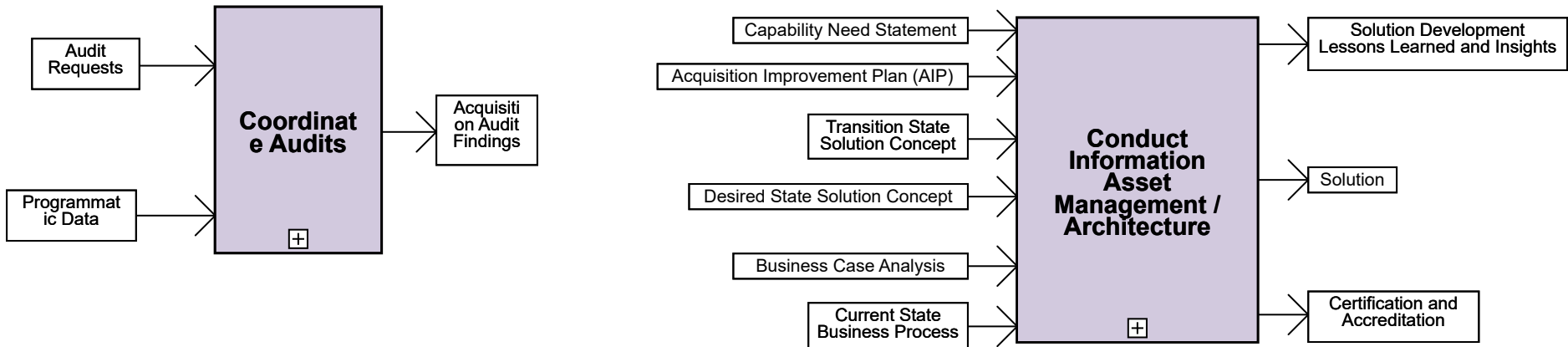
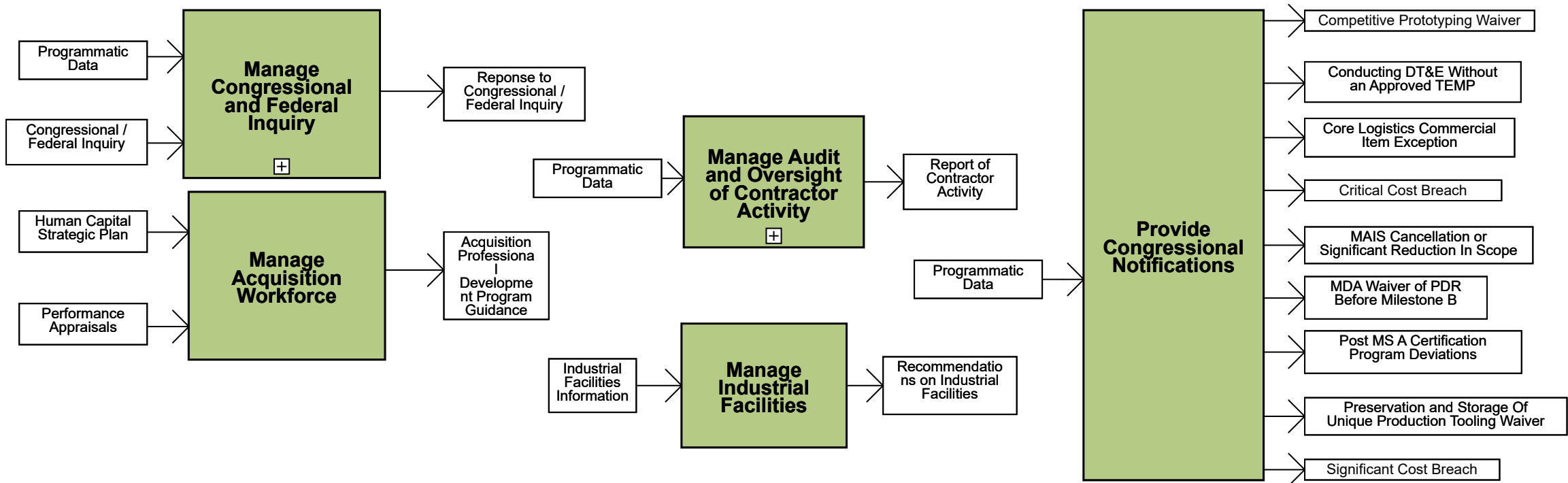
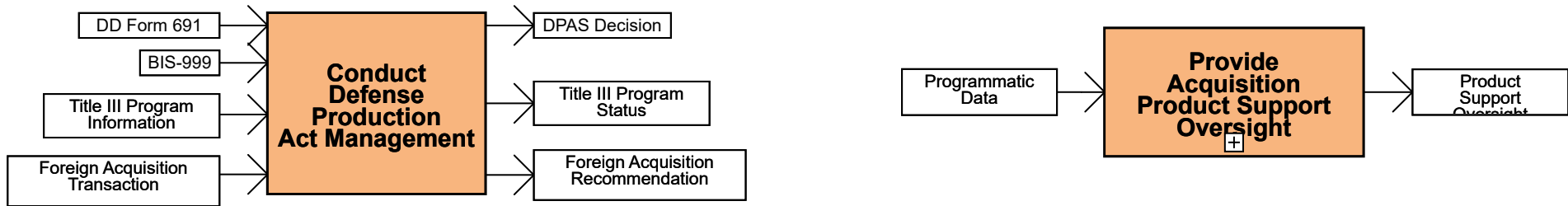

Go Up 1 Level

Acquisition Process Model

1.1.5.3.1 Manage Congressional and Federal Inquiry

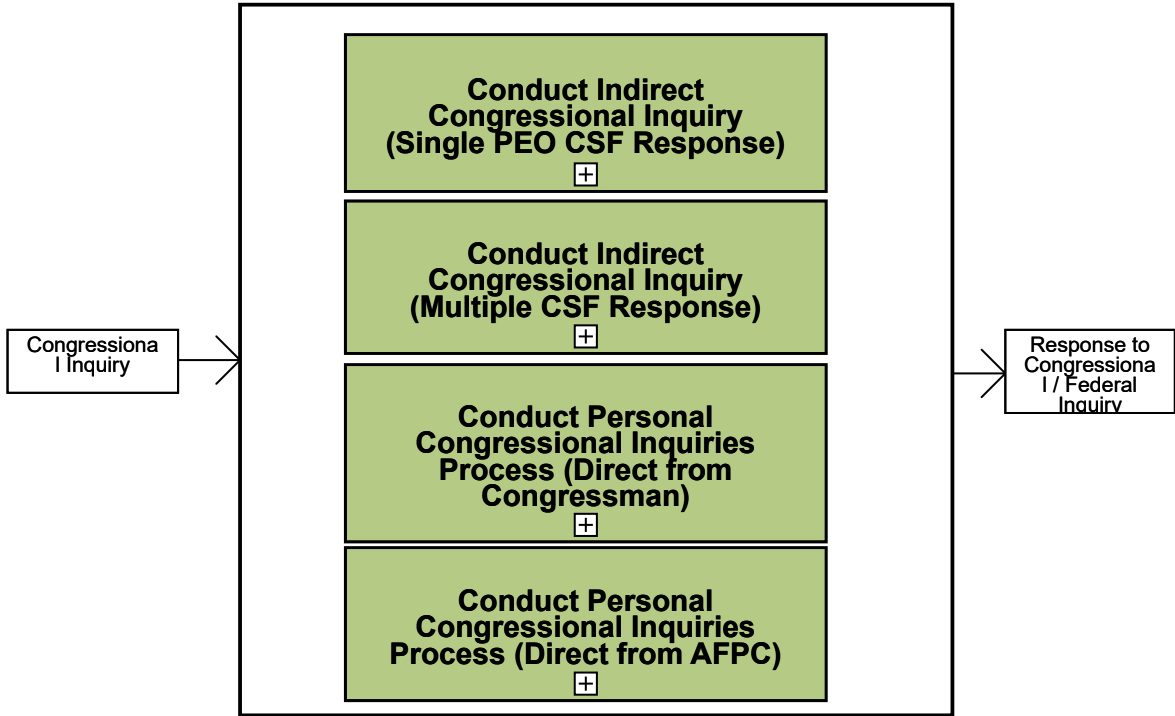

FWD

Go Up 1 Level

Acquisition Process Model

1.1.5.3.1.1 Conduct Indirect Congressional Inquiry (Single PEO CSF Response)

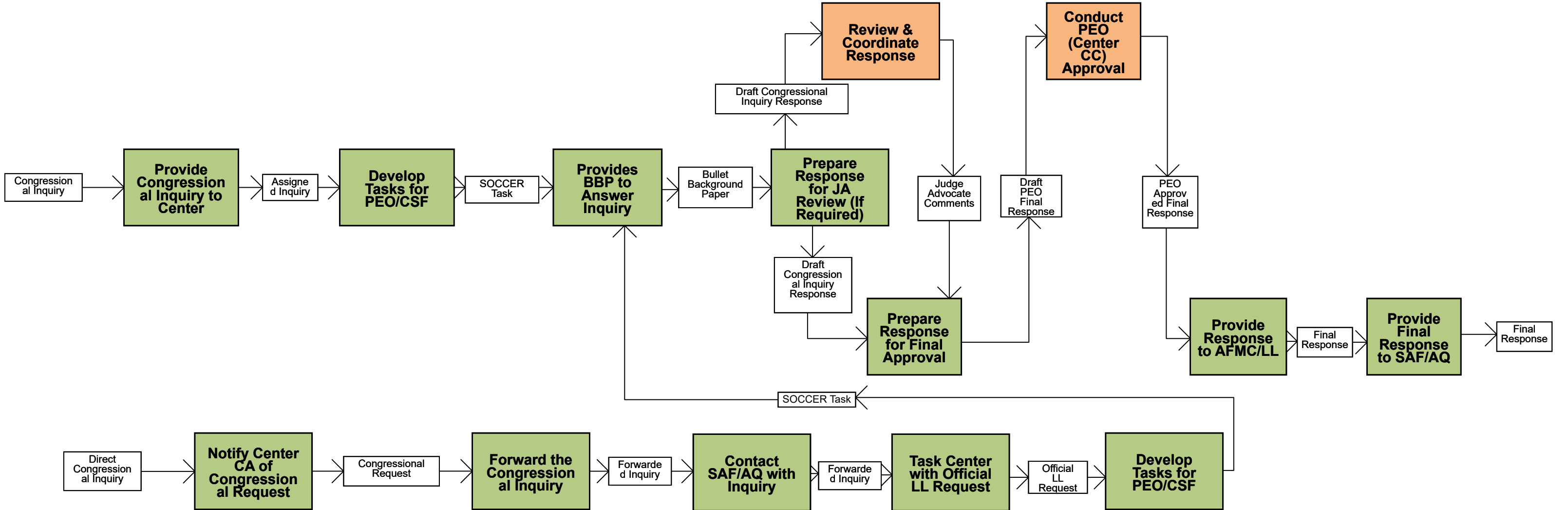

FWD

Go Up 1 Level

Acquisition Process Model

1.1.5.3.1.2 Conduct Indirect Congressional Inquiry (Multiple CSF Consolidated Response)

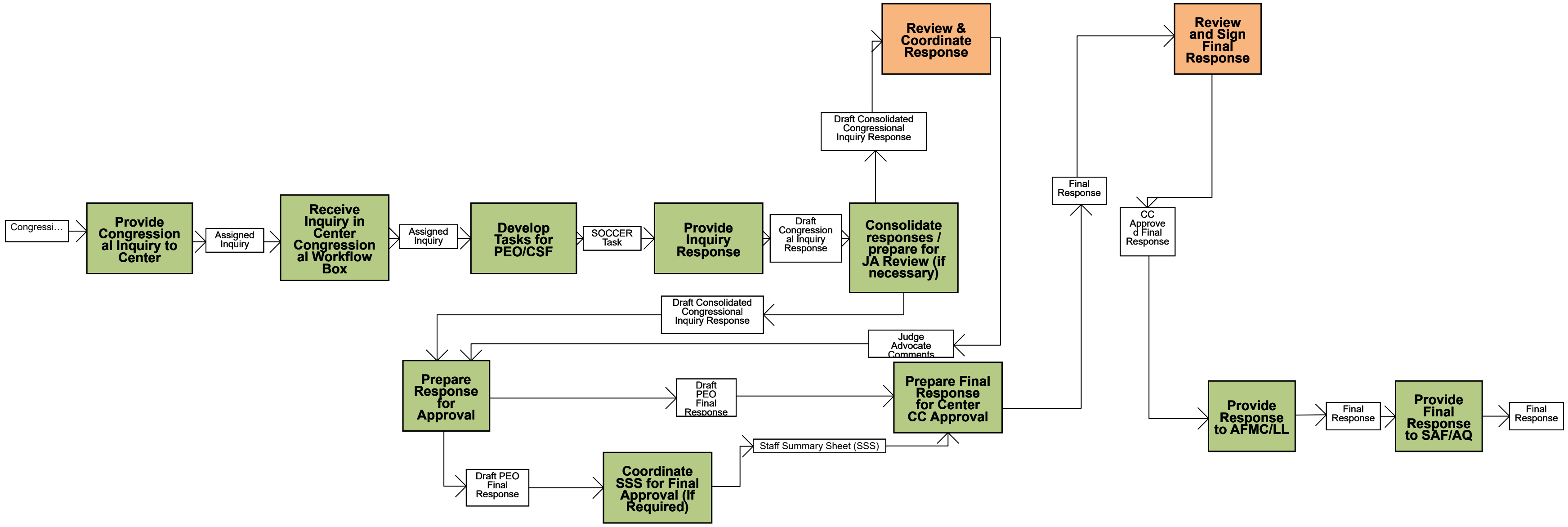

Go Up 1 Level

Acquisition Process Model

1.1.5.3.1.3 Conduct Personal Congressional Inquiries Process (Direct from Congressman)

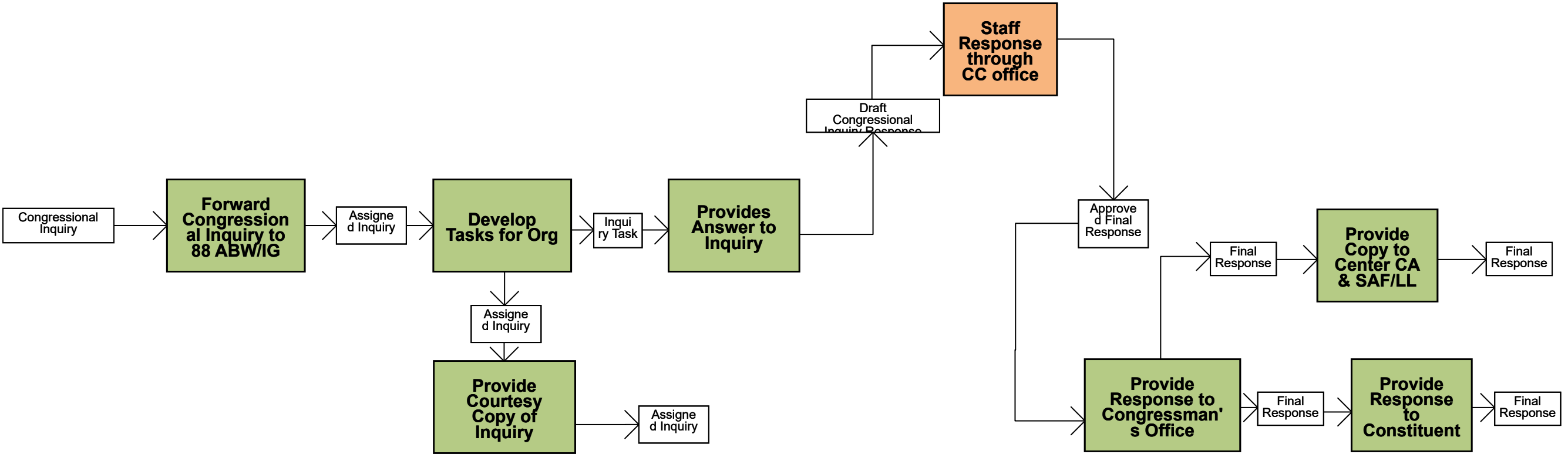

Go Up 1 Level

Acquisition Process Model

1.1.5.3.1.4 Conduct Personal Congressional Inquiries (Direct from AFPC)

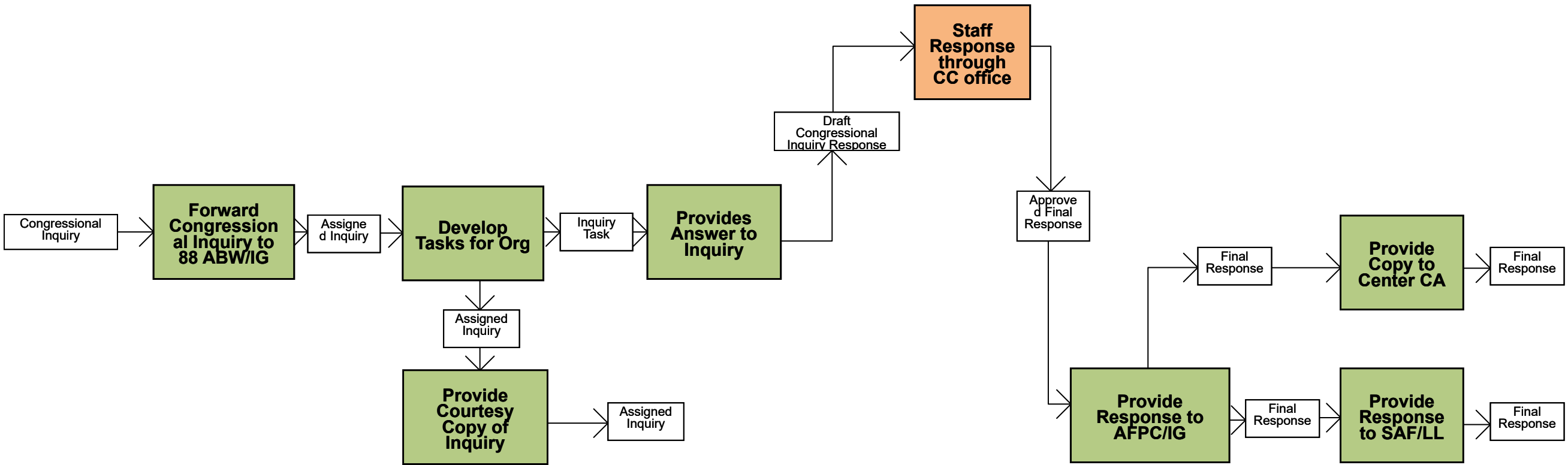

← BACK

Go Up 1 Level

Acquisition Process Model

1.1.5.3.3 Manage Audit and Oversight of Contractor Activity

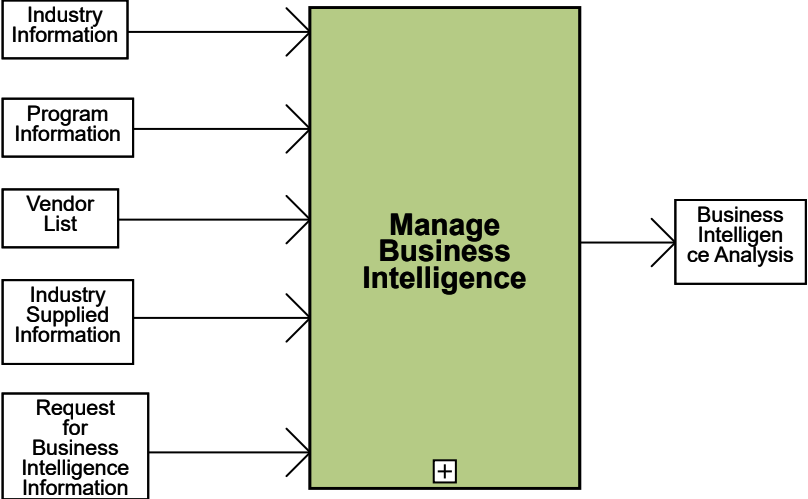

← BACK

FWD →

Go Up 1 Level

Acquisition Process Model

1.1.5.3.3.1 Manage Business Intelligence

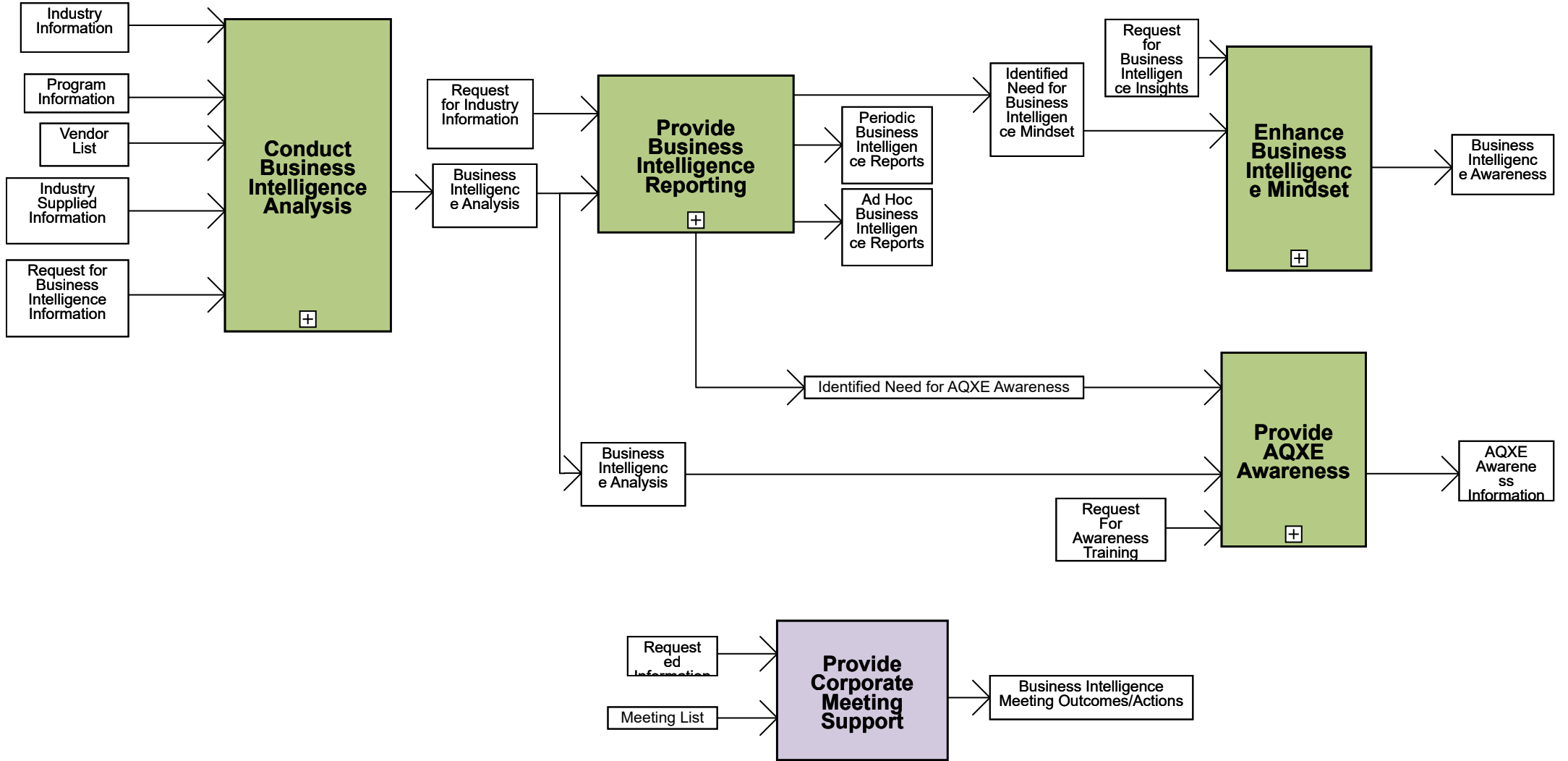

Go Up 1 Level

Acquisition Process Model

1.1.5.3.3.1.1 Conduct Business Intelligence Analysis

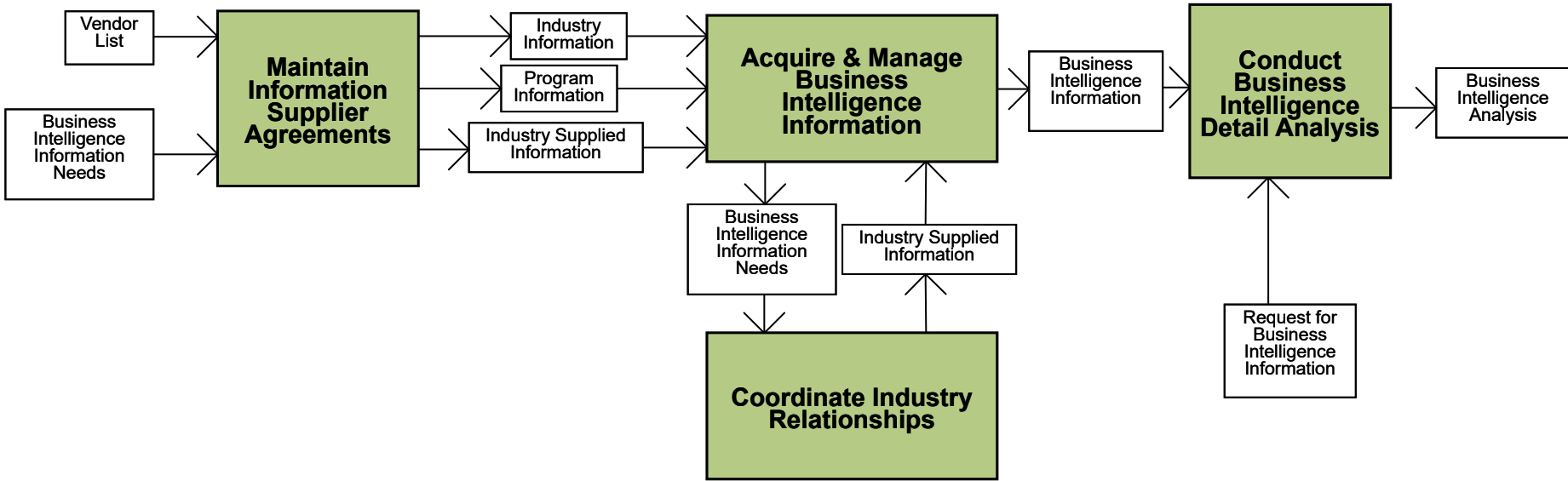

FWD

Go Up 1 Level

Acquisition Process Model

1.1.5.3.3.1.2 Provide Business Intelligence Reporting

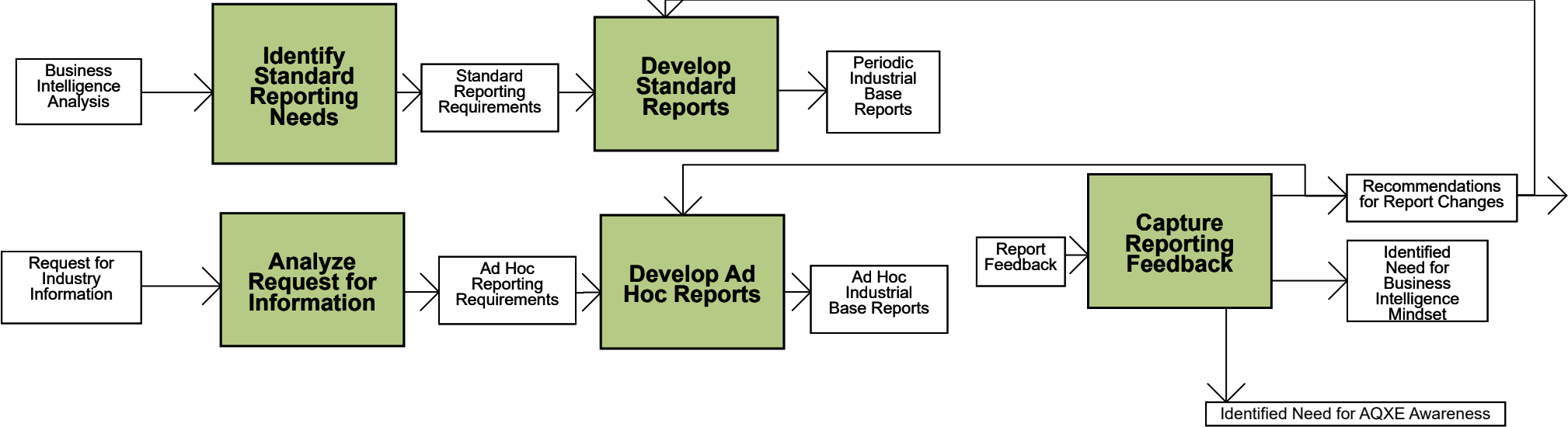

← BACK

FWD →

Go Up 1 Level

Acquisition Process Model

1.1.5.3.3.1.3 Enhance Business Intelligence Mindset

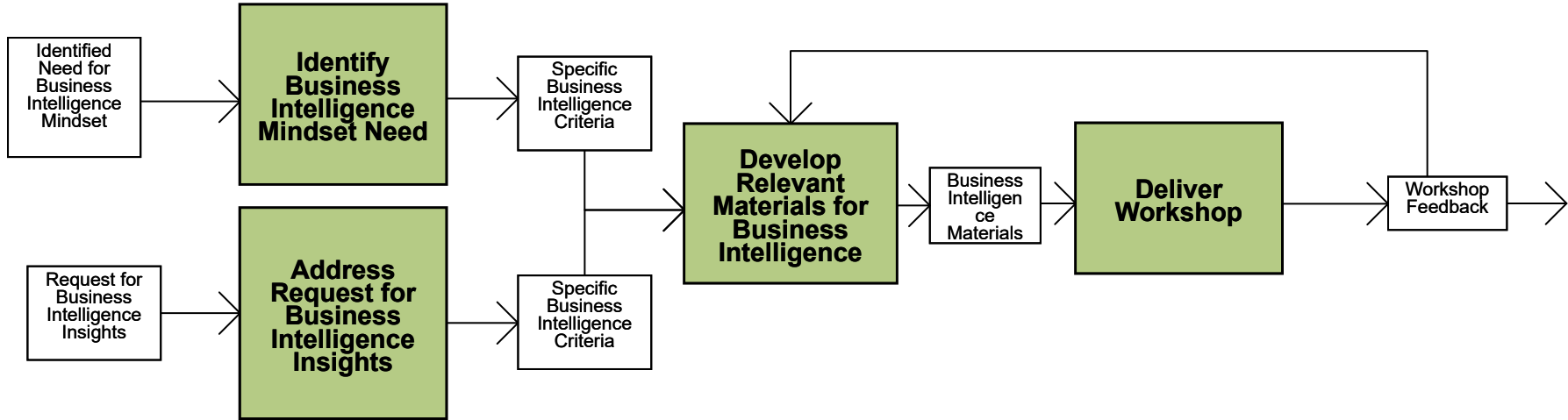

← BACK

FWD →

Go Up 1 Level

Acquisition Process Model

1.1.5.3.3.1.4 Provide AQXE Awareness

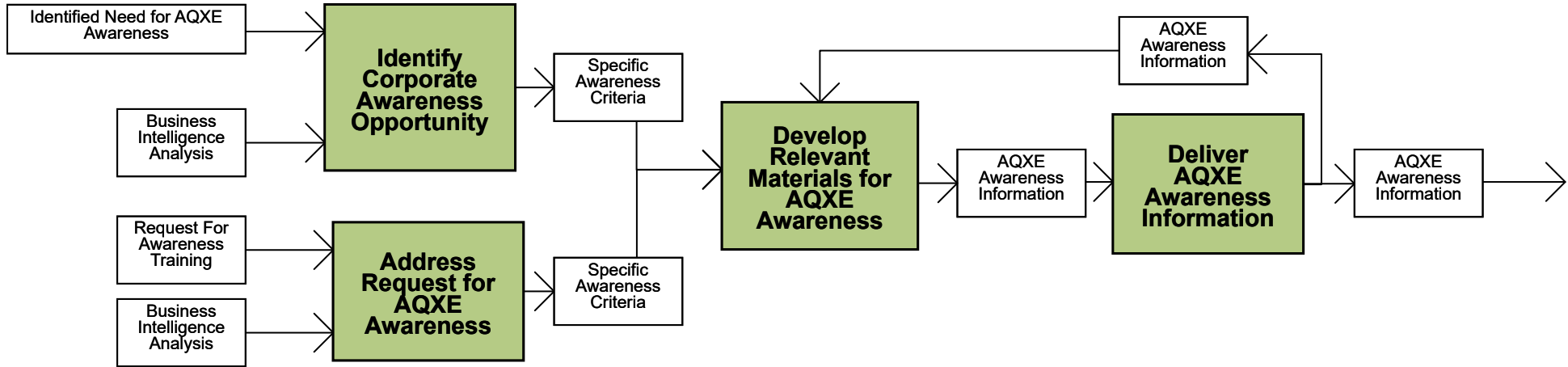

← BACK

Go Up 1 Level

Acquisition Process Model

1.1.5.3.4 Coordinate Audits

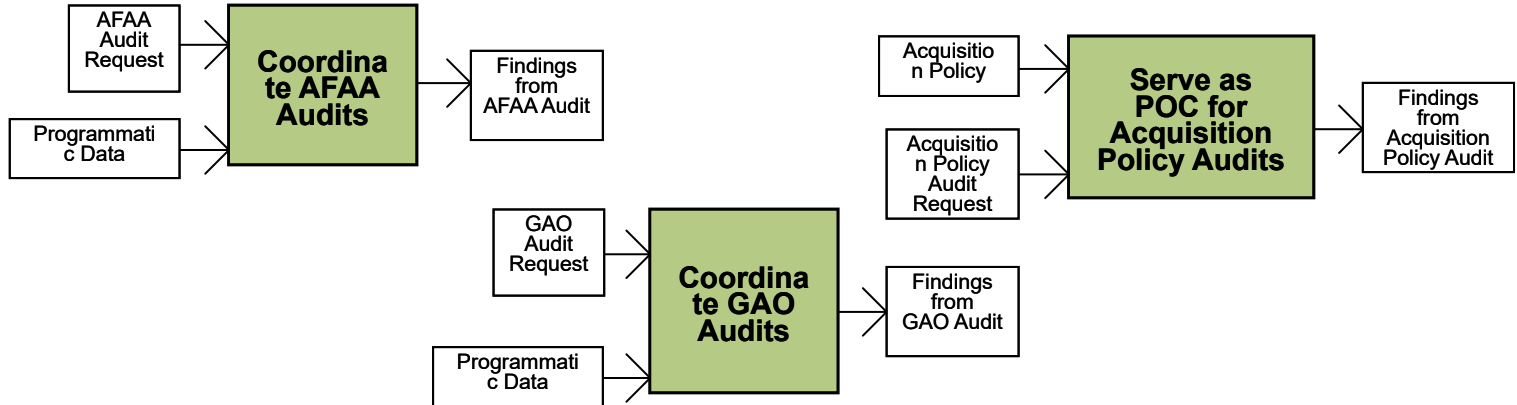

← BACK FWD →

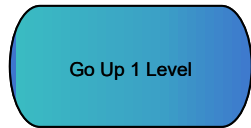

Acquisition Process Model

1.1.5.3.5 Conduct Information Asset Management Architecture

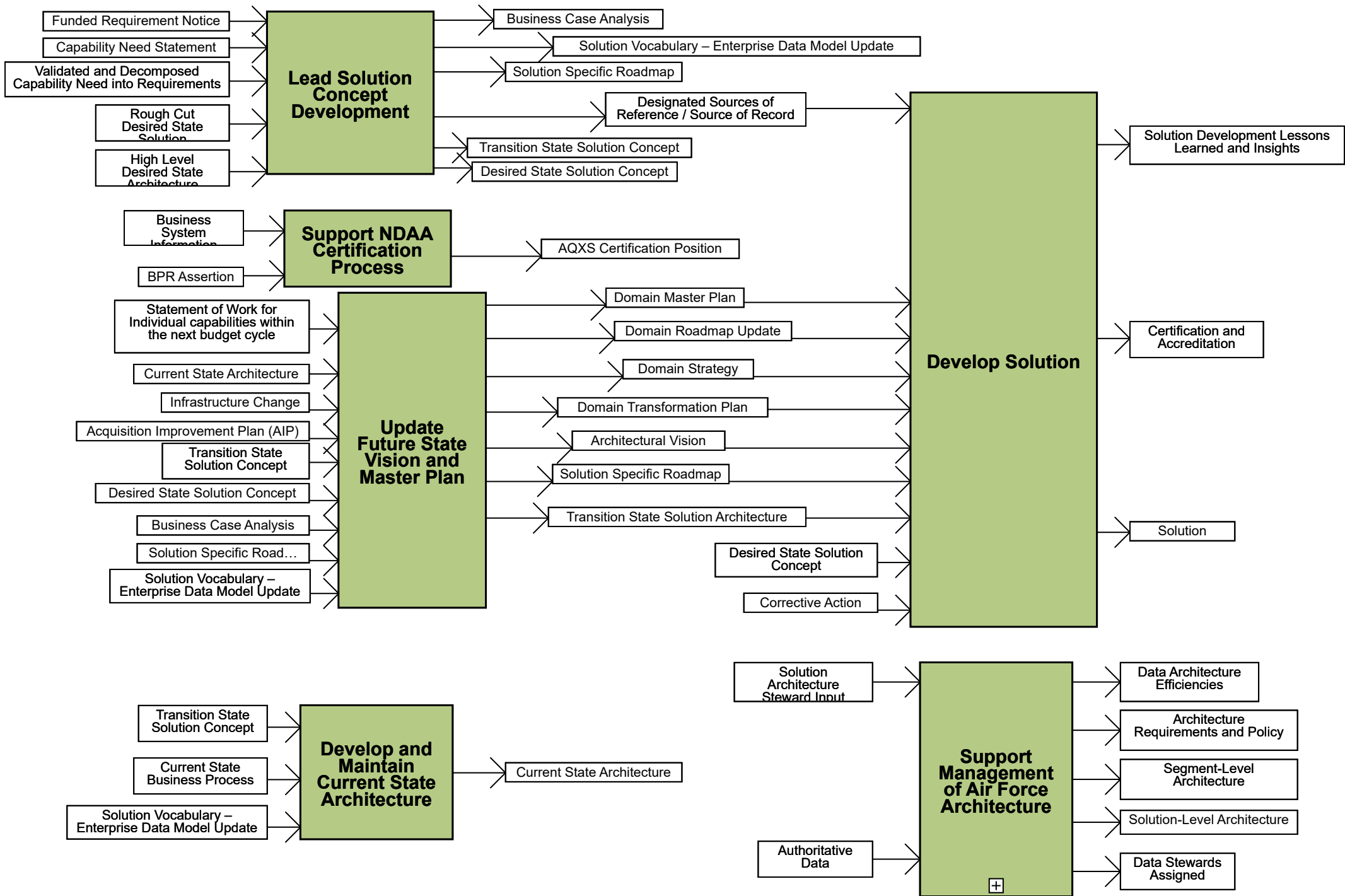

Go Up 1 Level

Acquisition Process Model

1.1.5.3.5.1 Support Management of Air Force Architecture

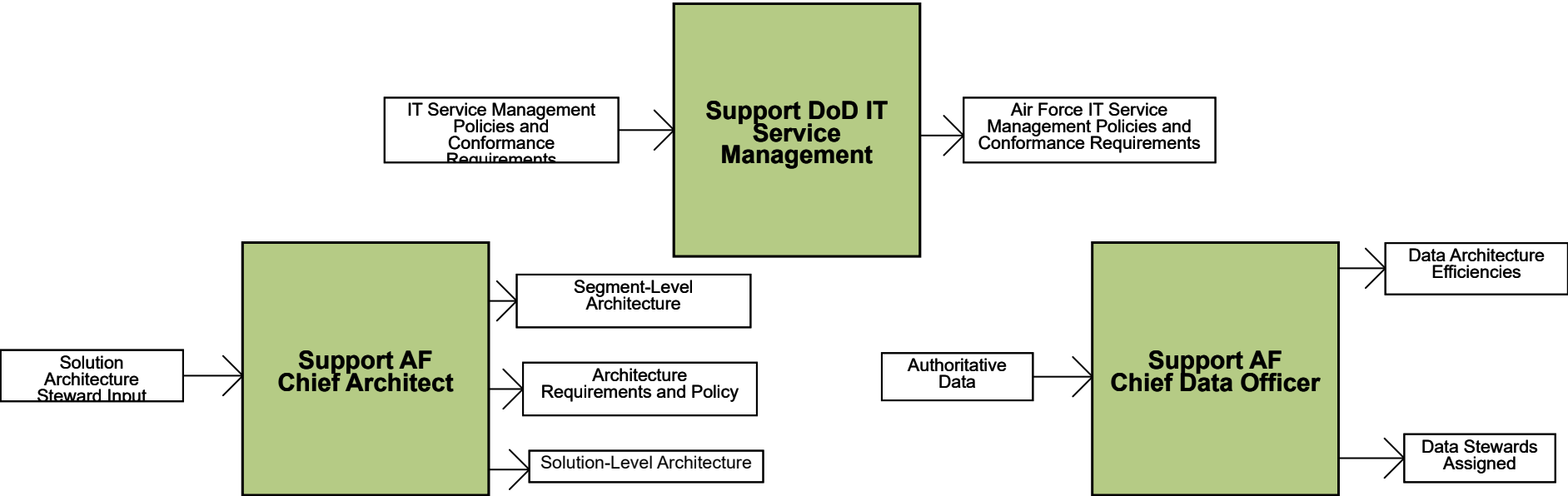

Go Up 1 Level

Acquisition Process Model

1.1.5.3.6 Provide Acquisition Product Support Oversight

Programmatic Data

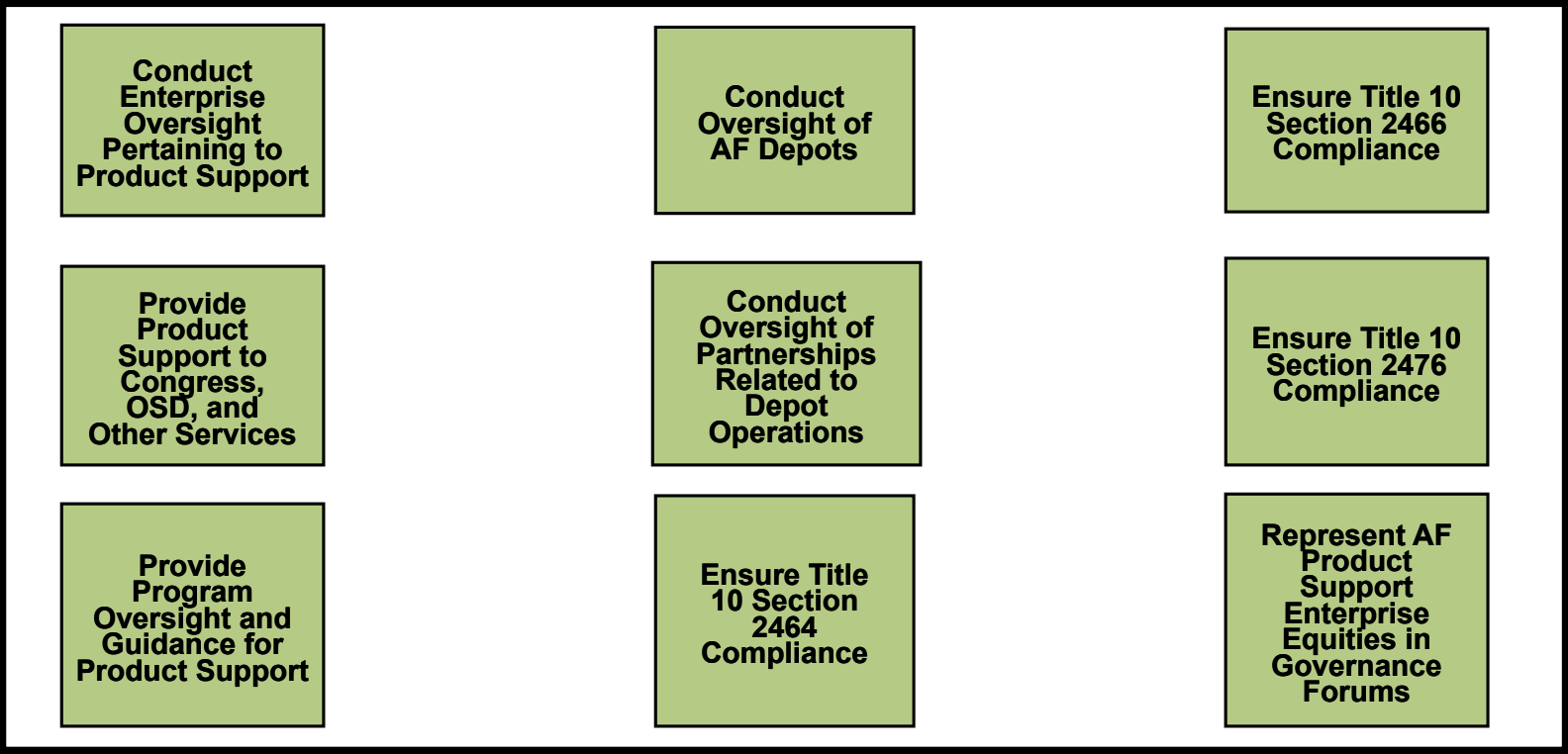

Product Support

BACK

Acquisition Process Model

1.1.5.4 Manage Acquisition Program Master List (APML)

Go Up 1 Level

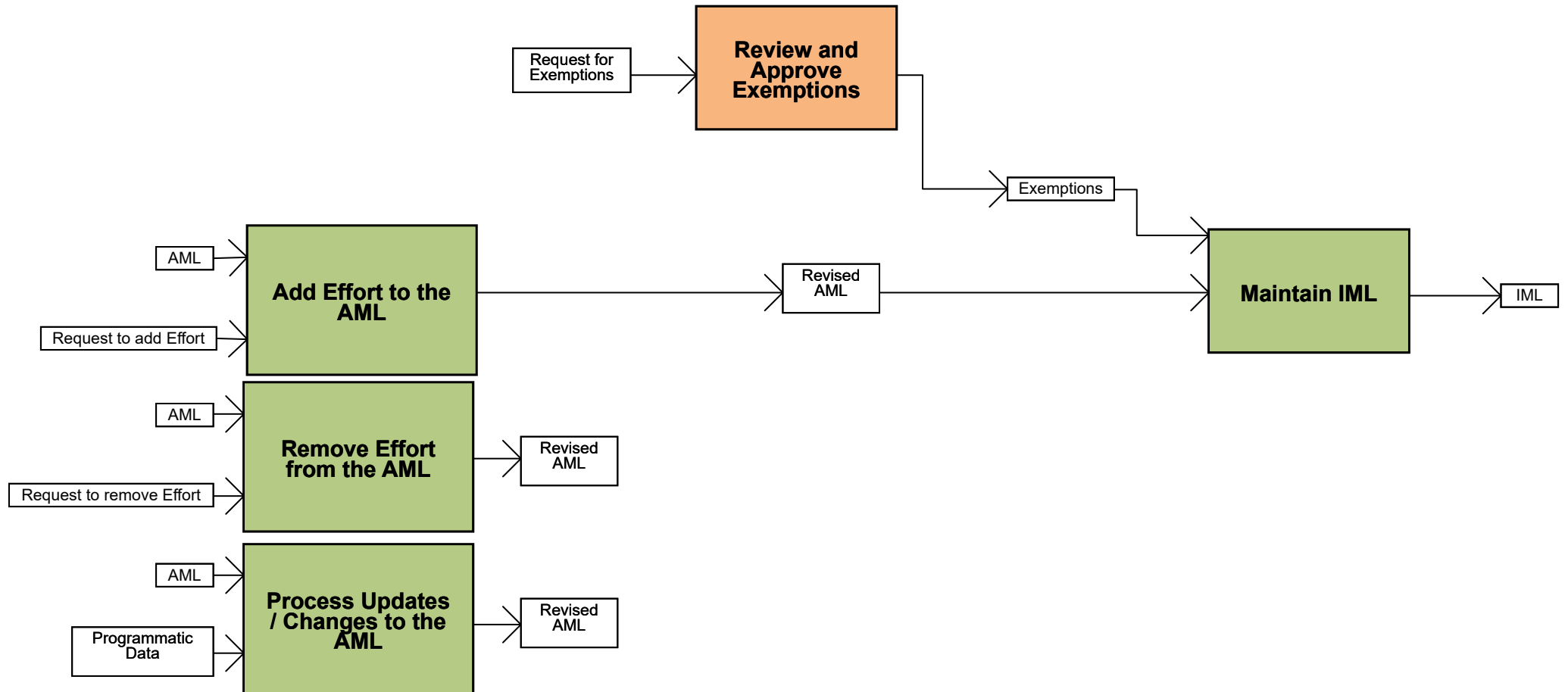

Go Up 1 Level

Acquisition Process Model

1.1.5.5 Conduct IT Portfolio Management

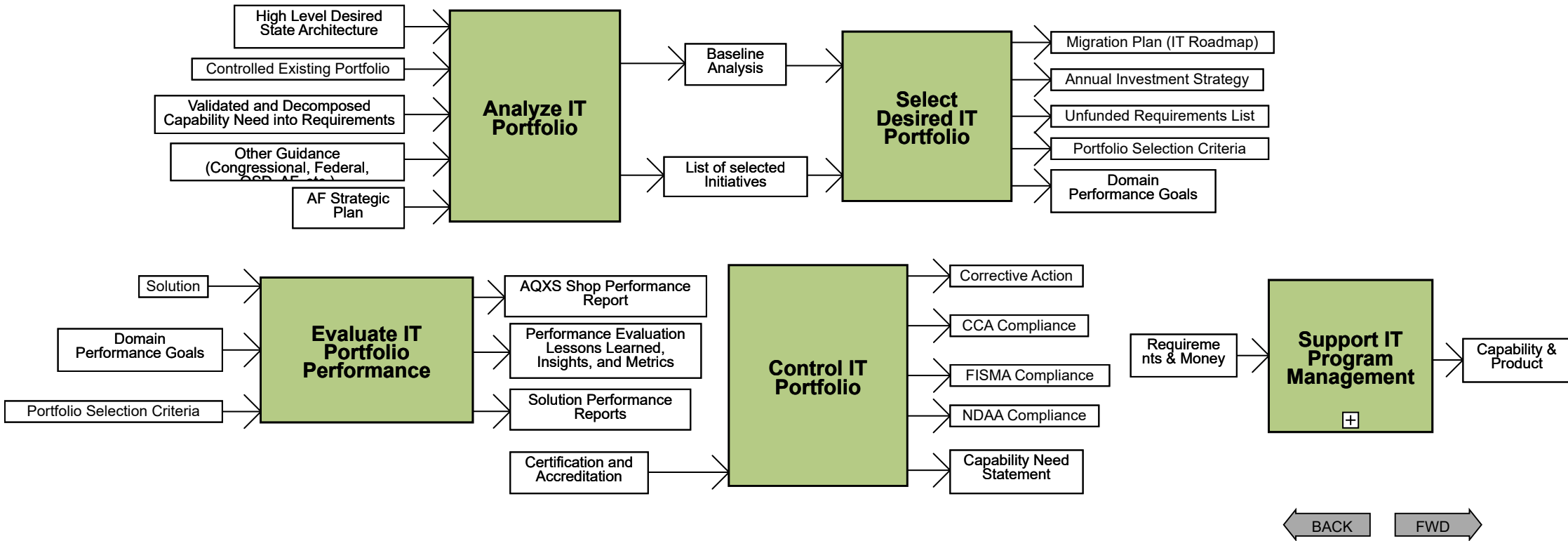

Go Up 1 Level

Acquisition Process Model

1.1.5.5.5 Support IT Program Management

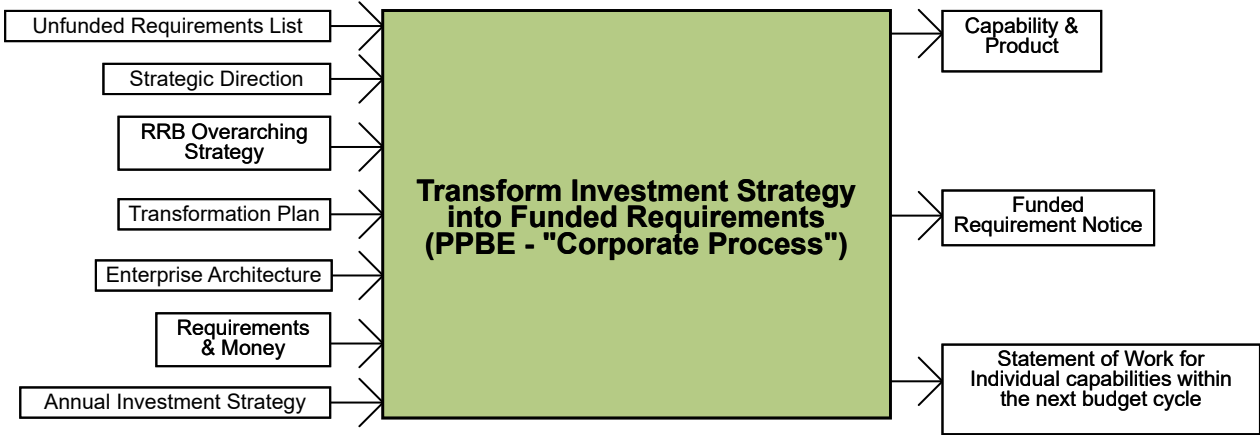

Go Up 1 Level

Acquisition Process Model

1.1.5.7 Provide Departmental Standardization Leadership

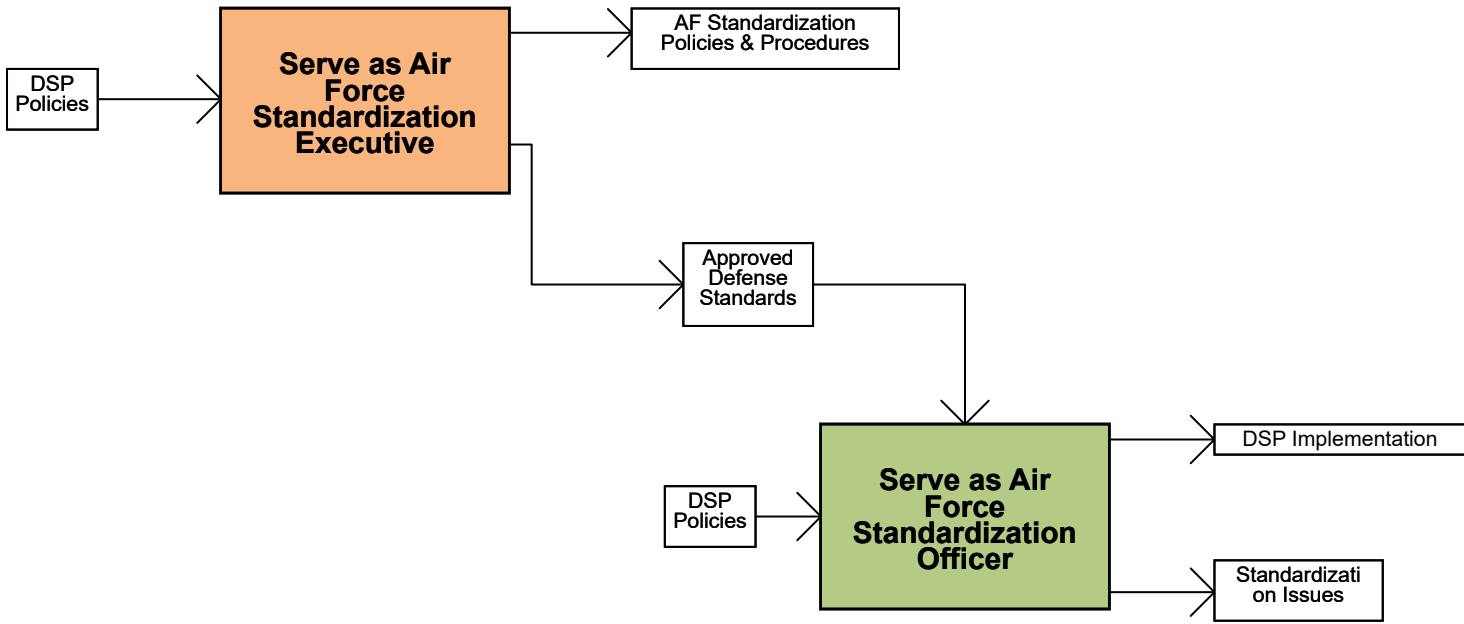

BACK FWD

Go Up 1 Level

Acquisition Process Model

1.1.5.8 Manage Acquisition Key Leadership Positions (KLP)

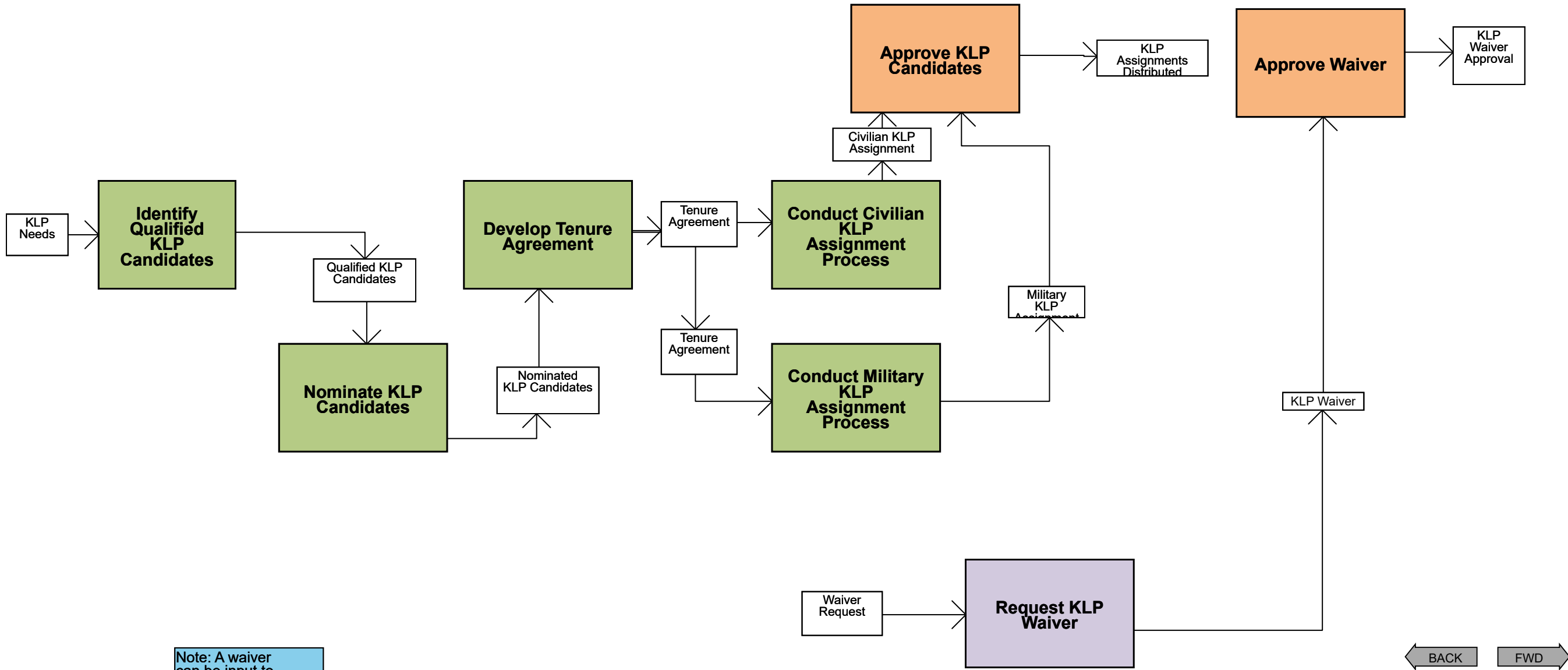

Note: A waiver can be input to any of the Core processes.

BACK FWD

Go Up 1 Level

Acquisition Process Model

1.1.5.9 Manage Scientific and Technology Information

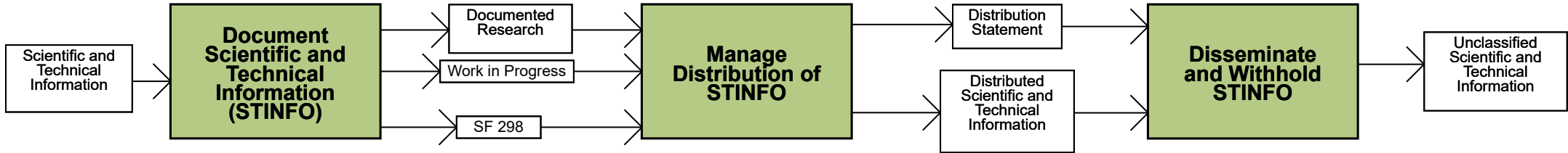

← BACK

Go Up 1 Level

Acquisition Process Model

1.2 Program and Budget (PPBE)

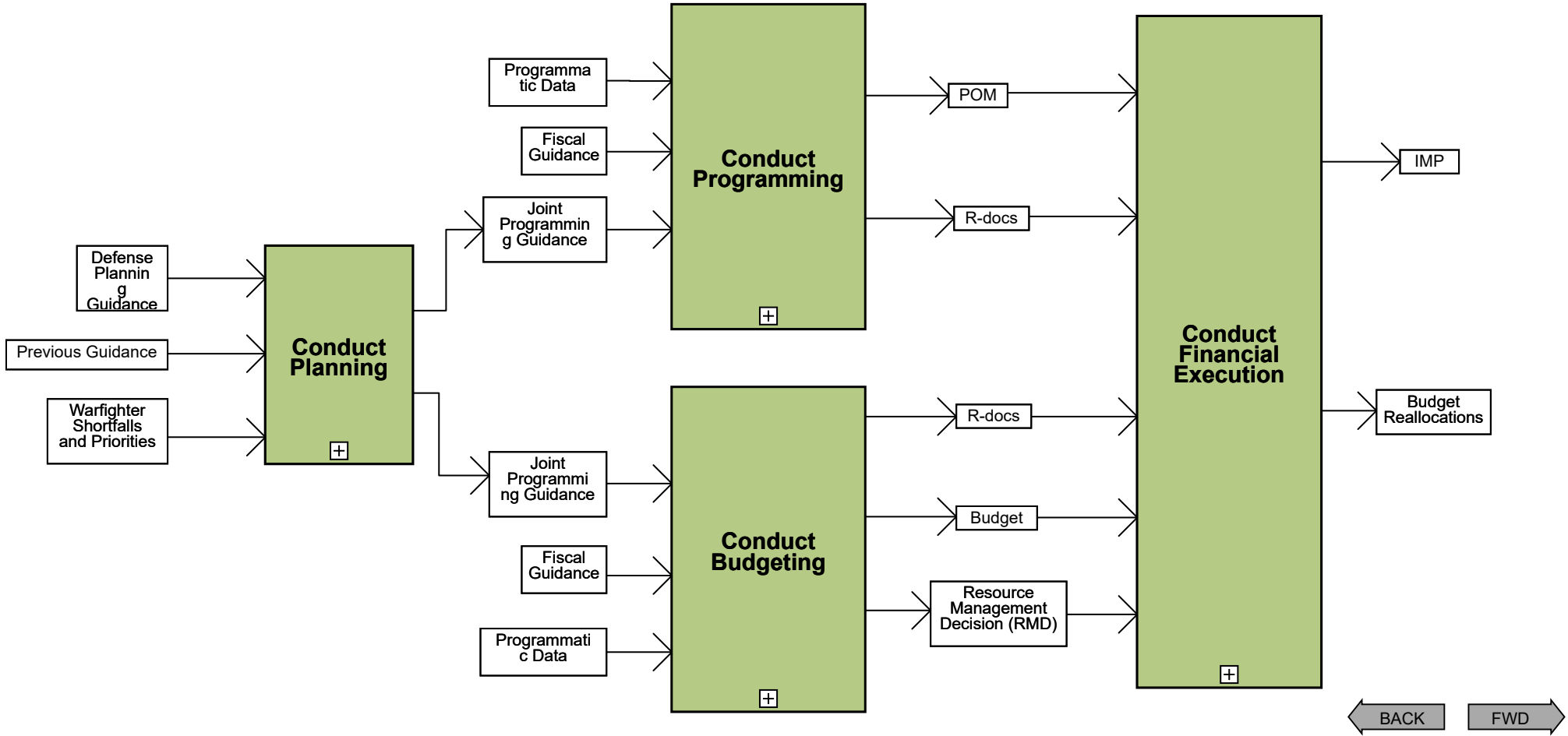

Go Up 1 Level

Acquisition Process Model

1.2.1 Conduct Planning

PEO View

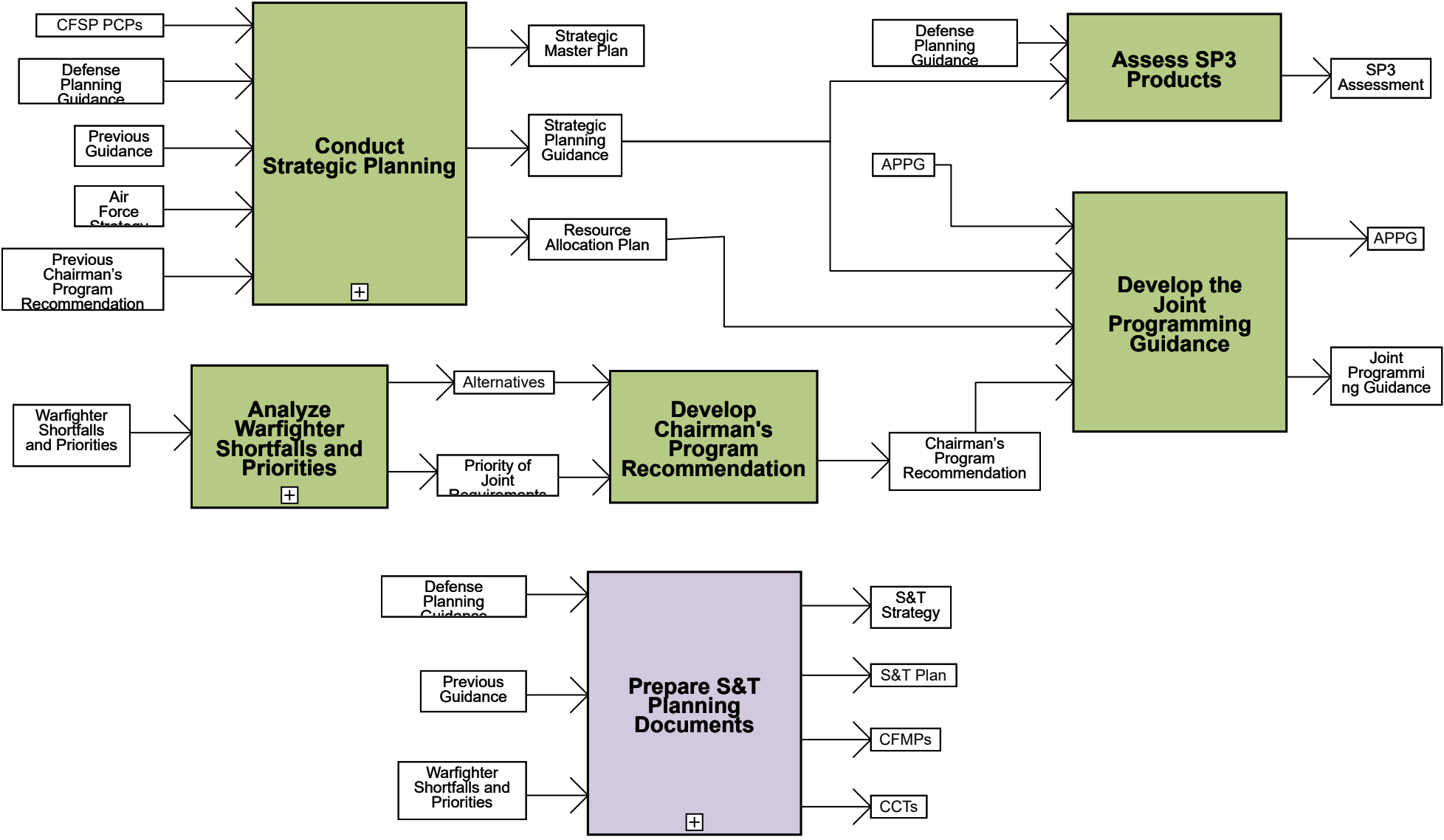

Note: The processes for Assess SP3 and Conduct Strategic Planning reference a document that has expired with no new reference document in place to supersede it. However, the processes are still being conducted and until a new document is in place, the expired document can be used as a guide.

FWD

Go Up 1 Level

Acquisition Process Model

1.2.1.1 Conduct Strategic Planning

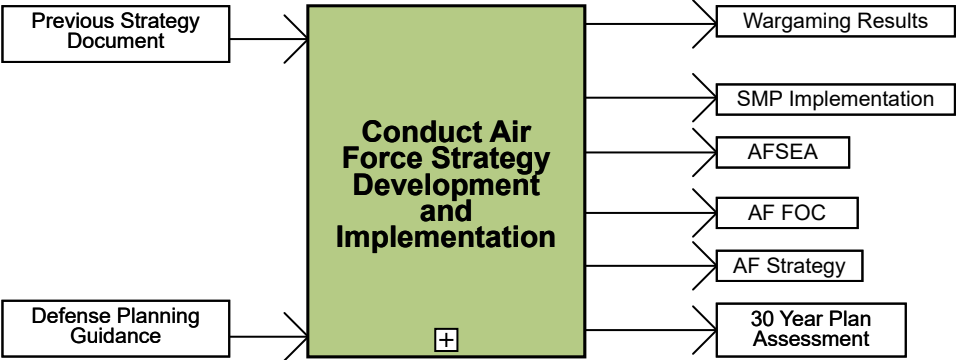

FWD →

Go Up 1 Level

Acquisition Process Model

1.2.1.1.1 Conduct Air Force Strategy Development and Implementation

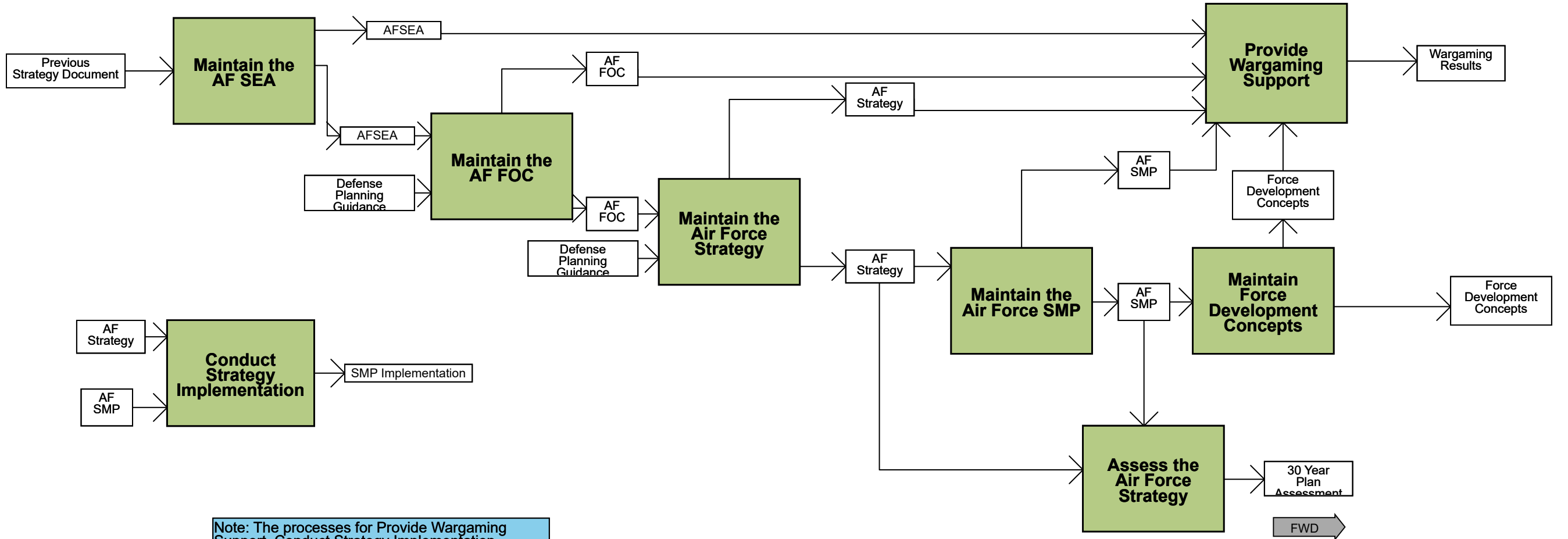

Note: The processes for Provide Wargaming Support, Conduct Strategy Implementation, and Maintain Force Development Concepts reference a document that has expired with no new reference document in place to supersede it. However, the processes are still being conducted and until a new document is in place, the expired document can be used as a guide.

Go Up 1 Level

Acquisition Process Model

1.2.1.1.2 Conduct Air Force Strategic Planning

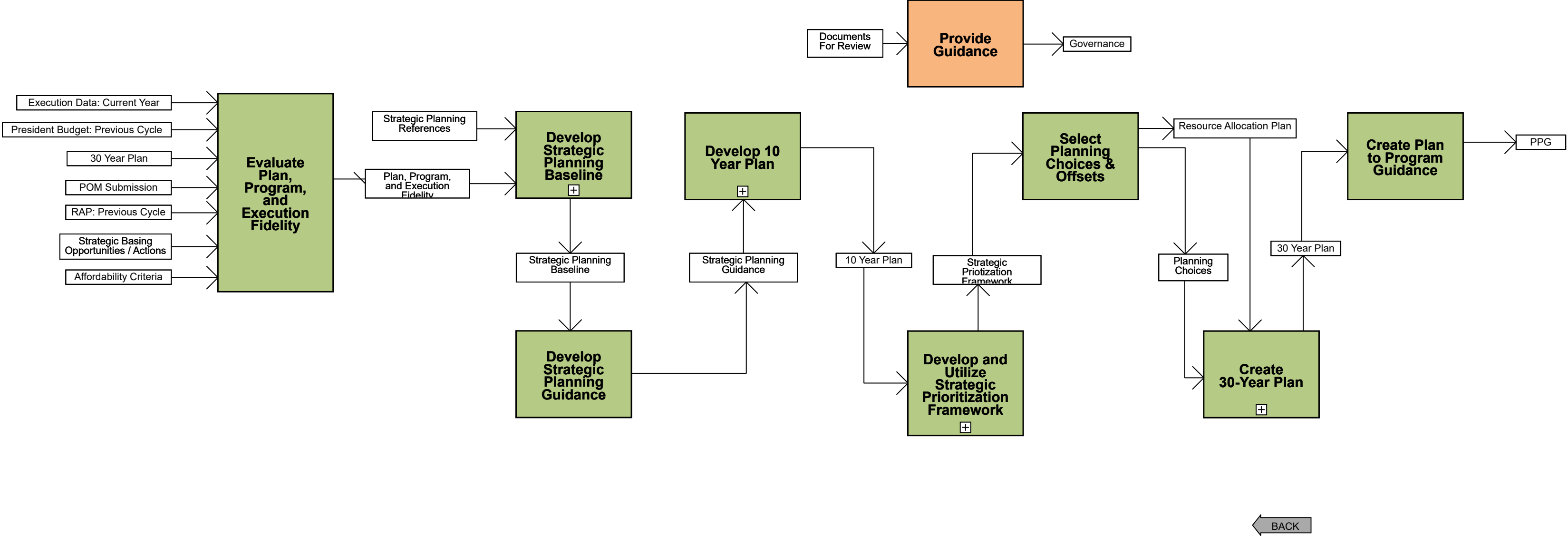



Acquisition Process Model

1.2.1.1.2.2 Develop Strategic Planning Baseline

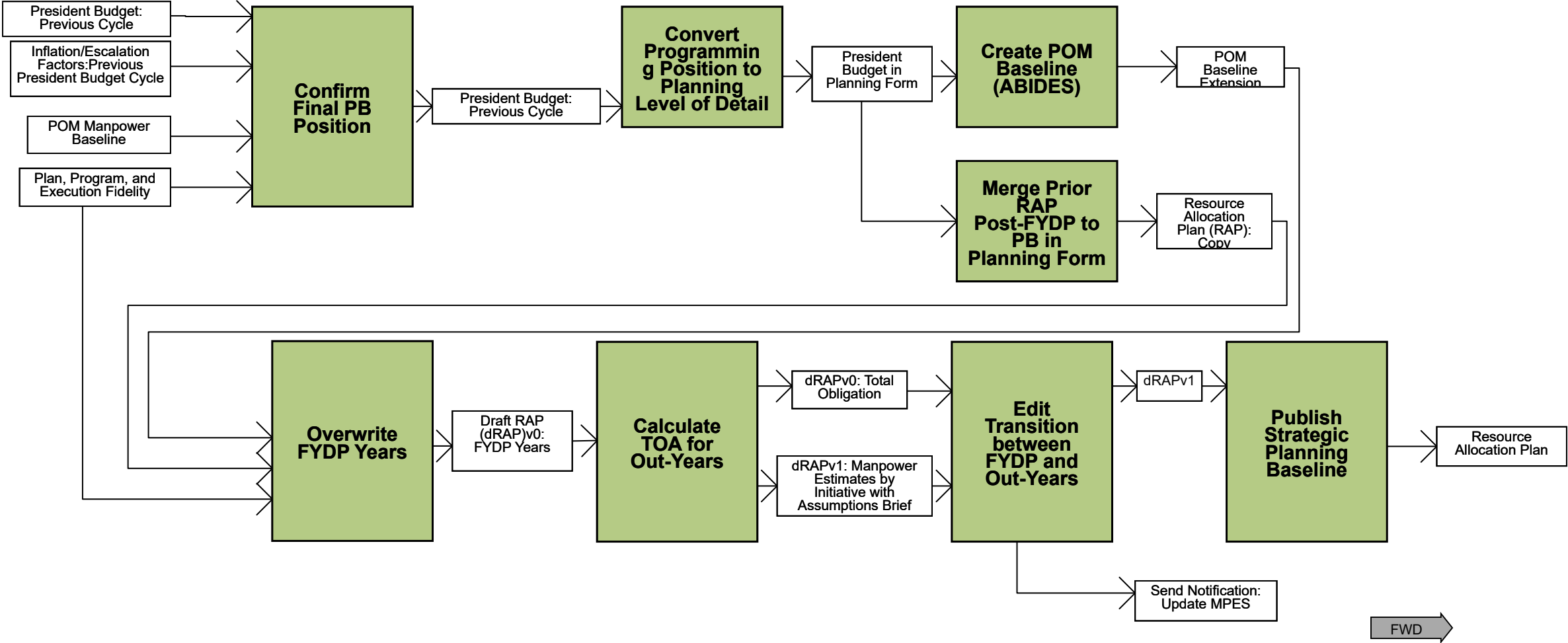

Acquisition Process Model

1.2.1.1.2.4 Develop 10 Year Plan

Go Up 1 Level

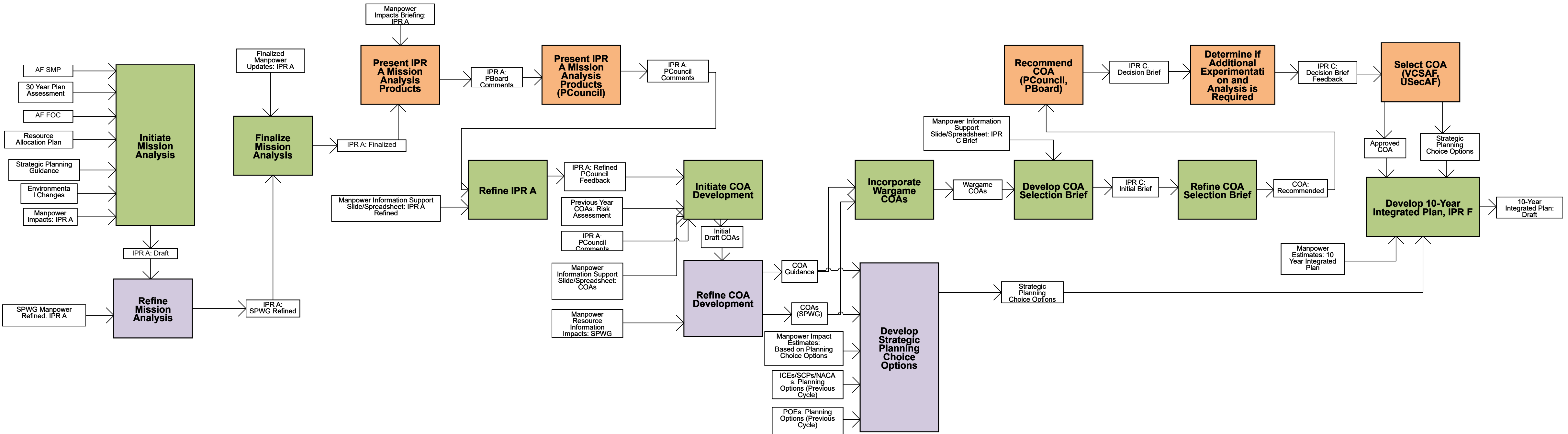

← BACK FWD →

Go Up 1 Level

Acquisition Process Model

1.2.1.1.2.5 Develop Strategic Prioritized List

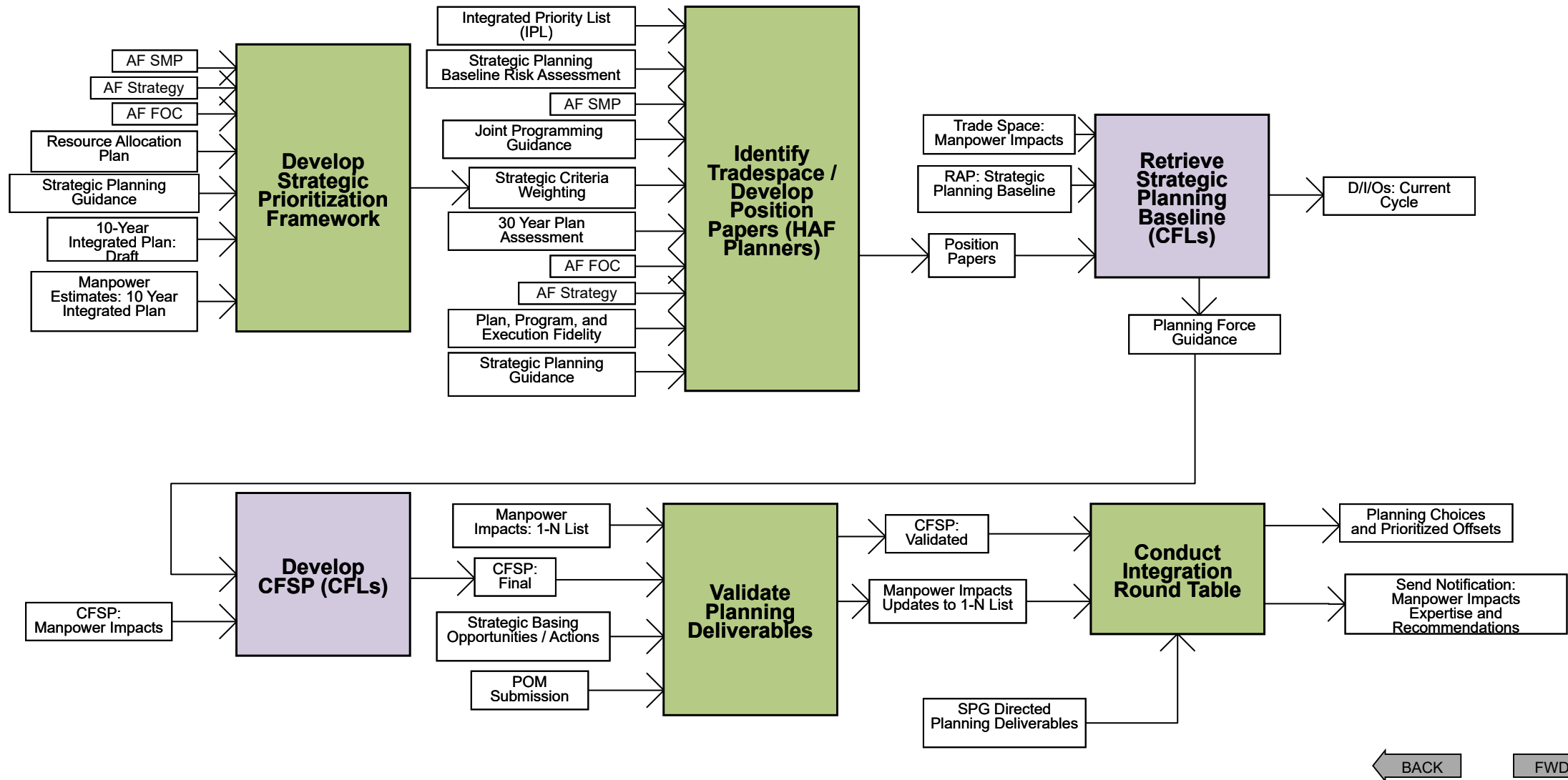

Go Up 1 Level

Acquisition Process Model

1.2.1.1.2.6 Select Planning Choices and Offsets

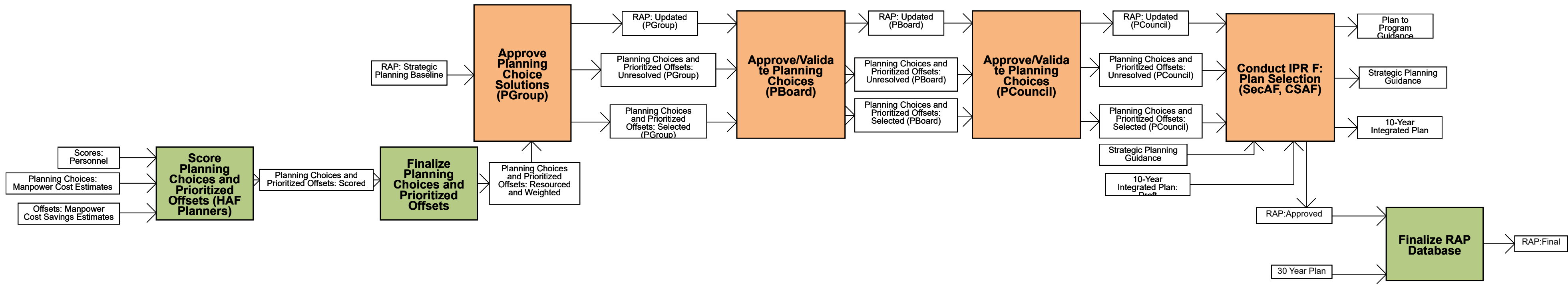

BACK

FWD

Go Up 1 Level

Acquisition Process Model

1.2.1.1.2.7 Create 30 Year Plan

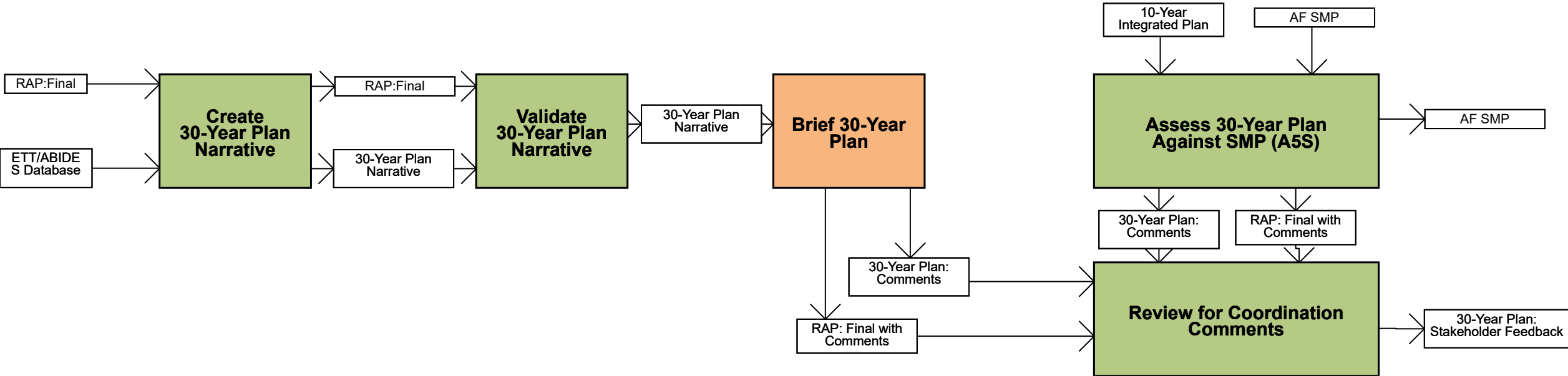

← BACK



Acquisition Process Model

1.2.1.3 Analyze Warfighter Shortfalls and Priorities

Warfighter Shortfalls and Priorities



- Analyze Joint Intelligence Estimate (JIE), Joint Strategic Assessment (JSA), and Joint Strategy Review (JSR)
- Analyze Chairman's Comprehensive Joint Assessment (CJA)
- Analyze Joint Concept Development (JCD)
- Analyze Joint Logistics Estimate (JLE)
- Analyze Joint Personnel Estimate (JPE)
- Analyze Chairman's Risk Assessment (CRA)
- Analyze Operational Availability Studies (OA)
- Analyze Joint Combat Capabilities Assessment (JCCA)
- Analyze Chairman's Readiness Systems (CRS)
- Analyze Global Force Management (GFM)
- Analyze Chairman's Program Recommendation (CPR)
- Analyze Chairman's Program Assessment (CPA)
- Analyze National Military Strategy (NMS)
- Analyze Joint Strategic Capabilities Plan (JSCP)

Alternatives

Priority of Joint

← BACK

FWD →

Go Up 1 Level

Acquisition Process Model

1.2.1.6 Prepare S&T Planning Documents

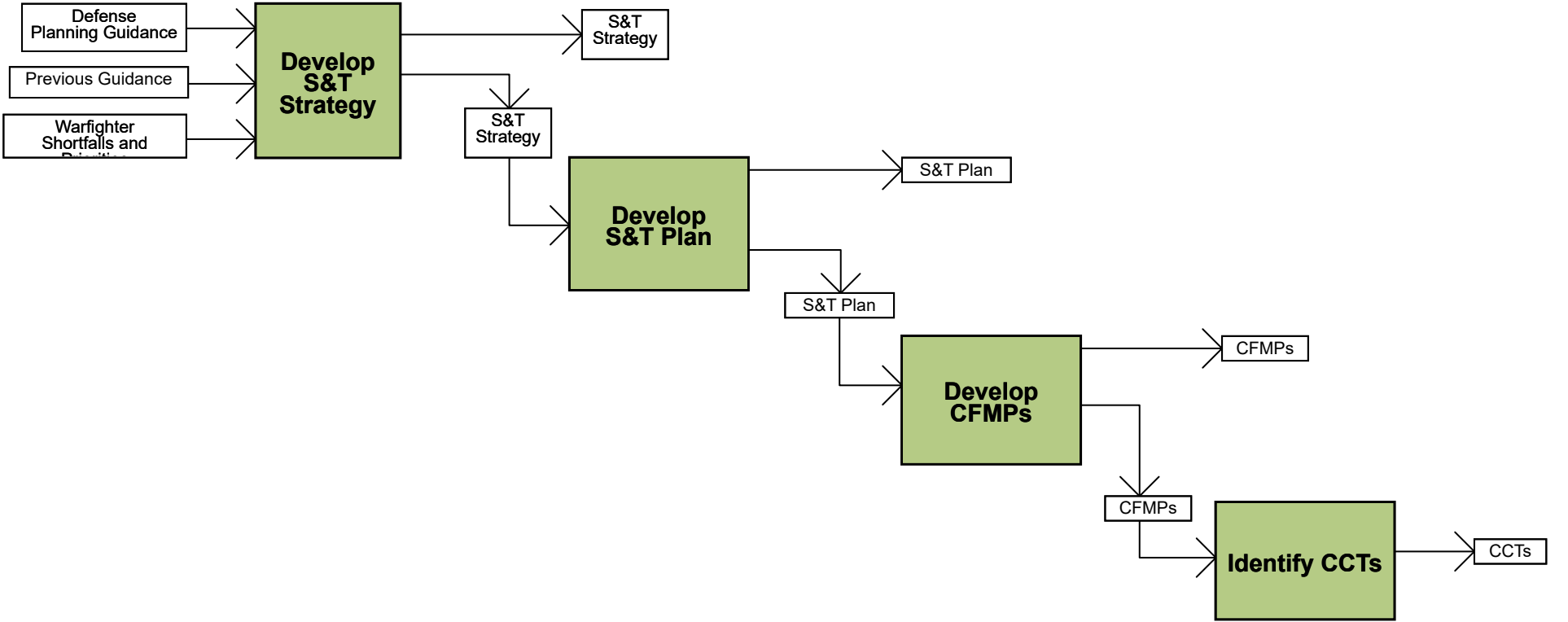

← BACK

Go Up 1 Level

Acquisition Process Model

1.2.2 Conduct Programming

PEO View

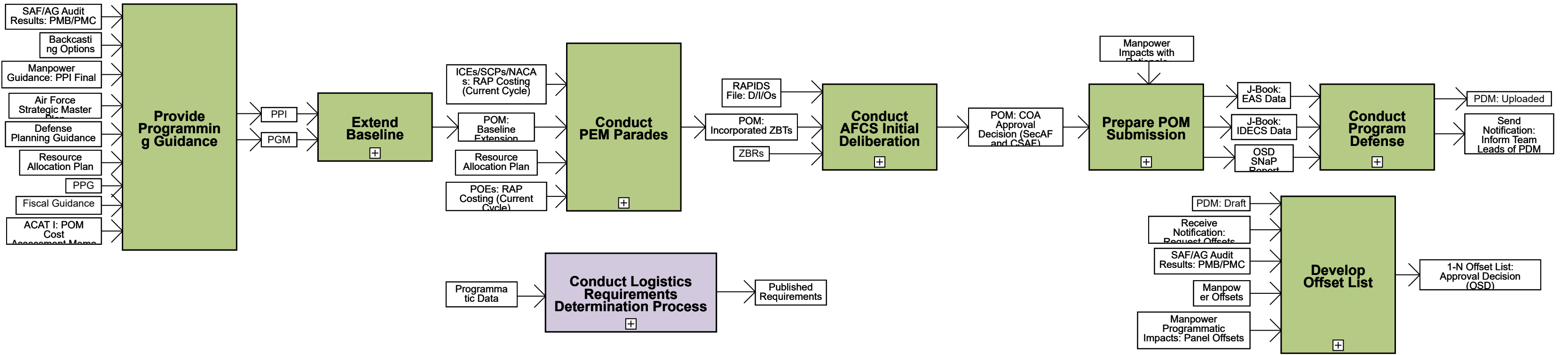

BACK FWD

Acquisition Process Model

1.2.2.2 Extend Baseline

Go Up 1 Level

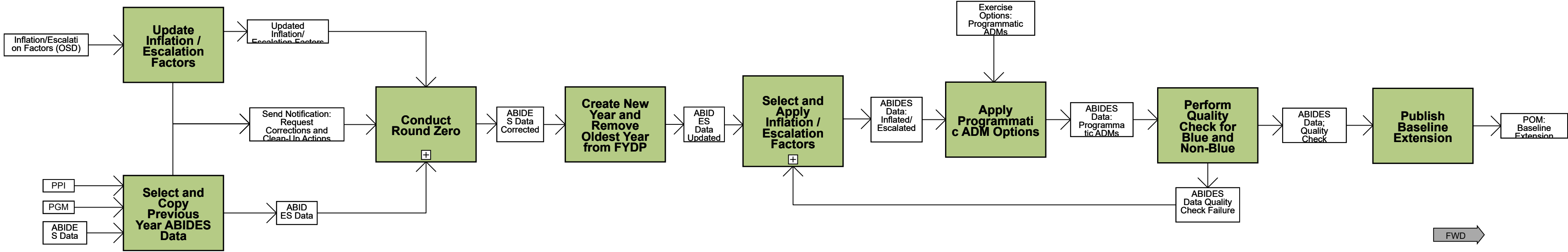

FWD

Go Up 1 Level

Acquisition Process Model

1.2.2.2.3 Conduct Round Zero

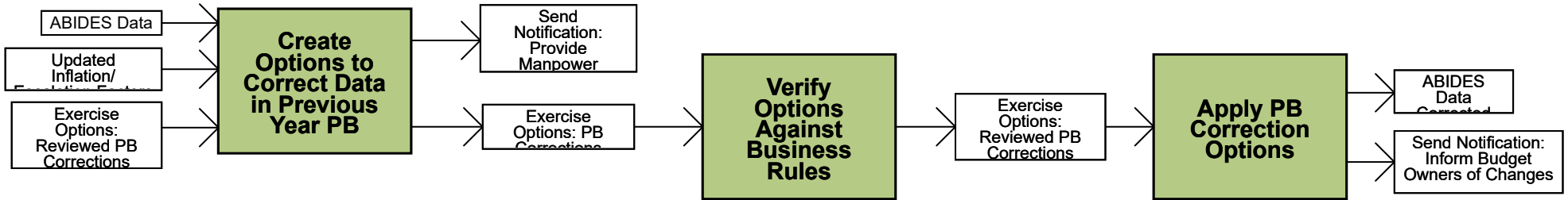

FWD →

Go Up 1 Level

Acquisition Process Model

1.2.2.2.5 Select and Apply Inflation/Escalation Factors

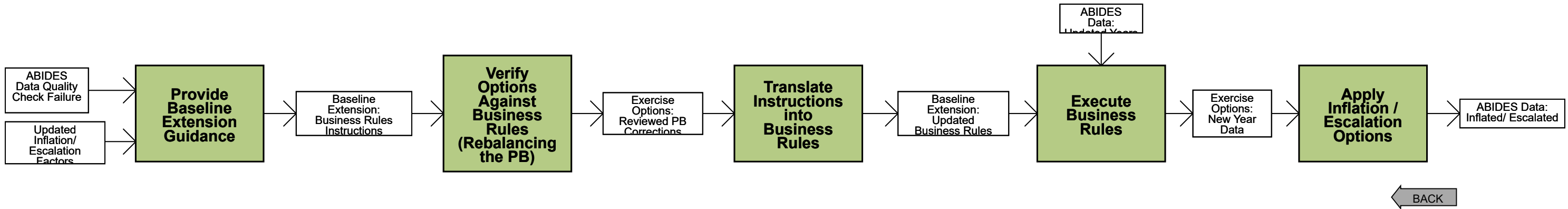

Go Up 1 Level

Acquisition Process Model

1.2.2.3 Conduct PEM Parades

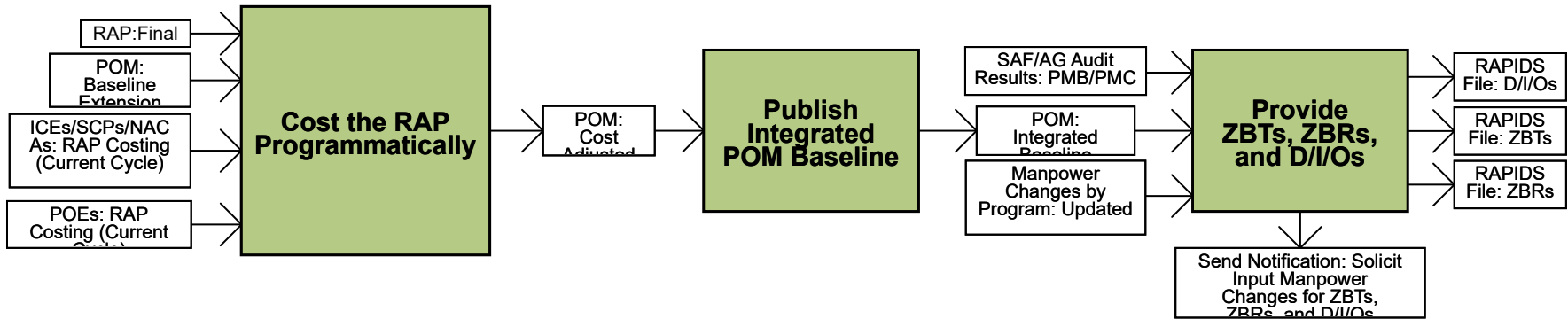

← BACK

FWD →

Acquisition Process Model

1.2.2.4 Conduct AFCS Deliberation

Go Up 1 Level

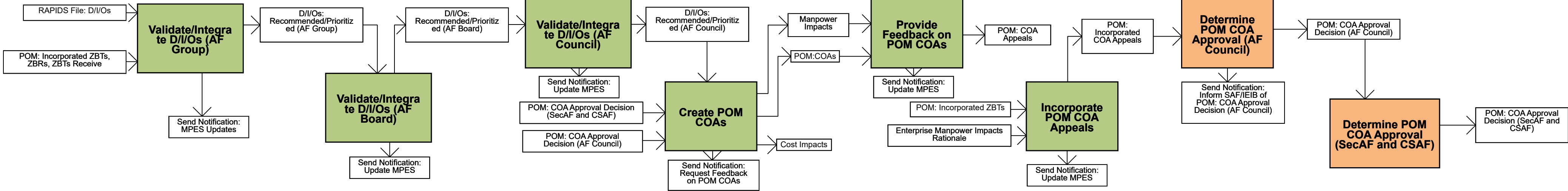

← BACK FWD →

Go Up 1 Level

Acquisition Process Model

1.2.2.5 Prepare POM Submission

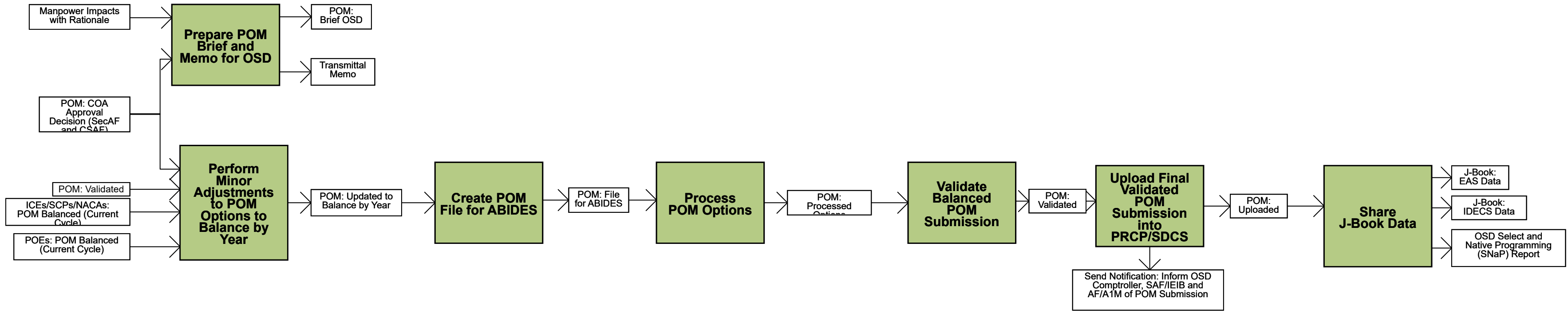

BACK

FWD

Go Up 1 Level

Acquisition Process Model

1.2.2.6 Conduct Program Defense

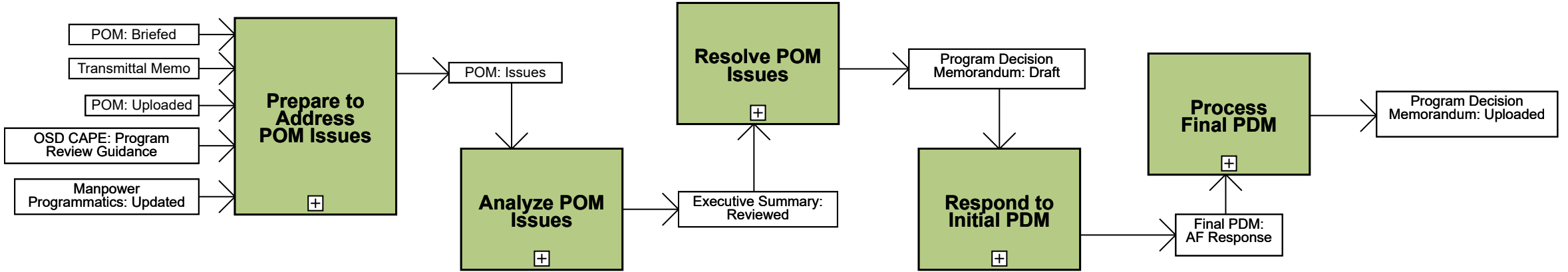

← BACK

FWD →

Go Up 1 Level

Acquisition Process Model

1.2.2.6.1 Prepare to Address POM Issues

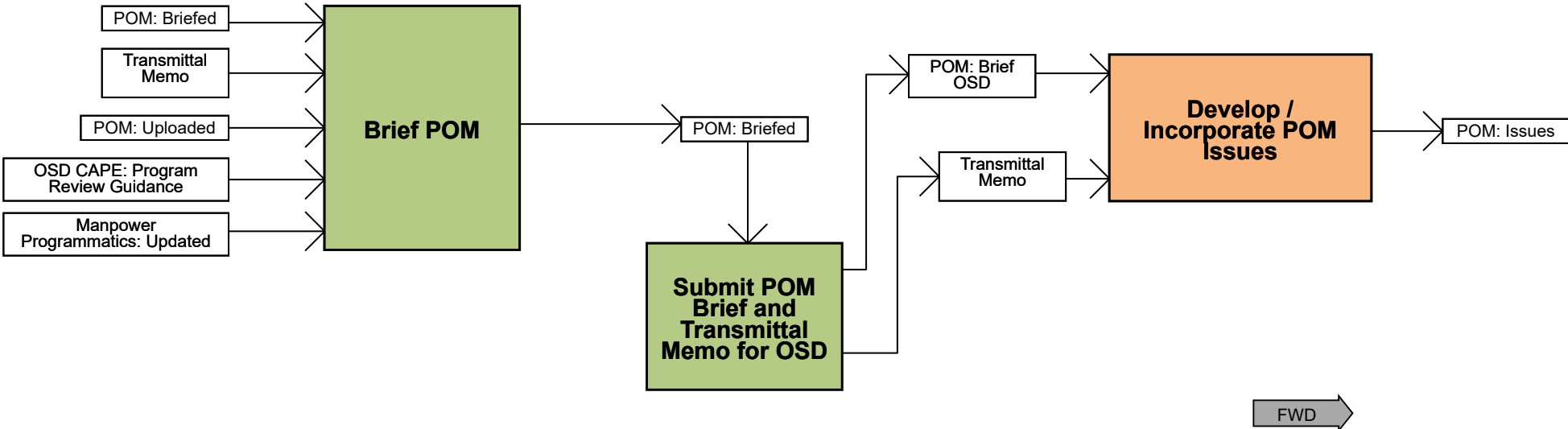

Go Up 1 Level

Acquisition Process Model

1.2.2.6.2 Analyze POM Issues

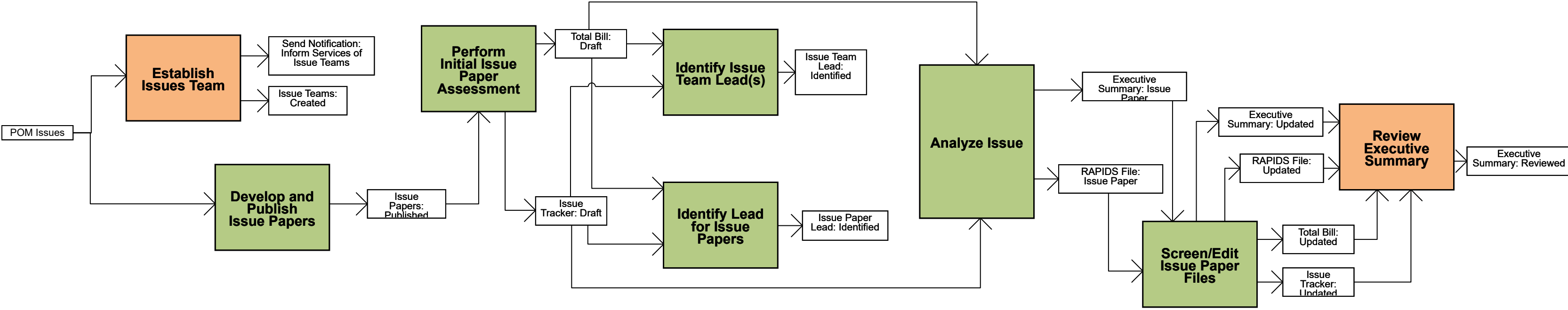

← BACK

FWD →

Acquisition Process Model

1.2.2.6.3 Resolve POM Issues

Go Up 1 Level

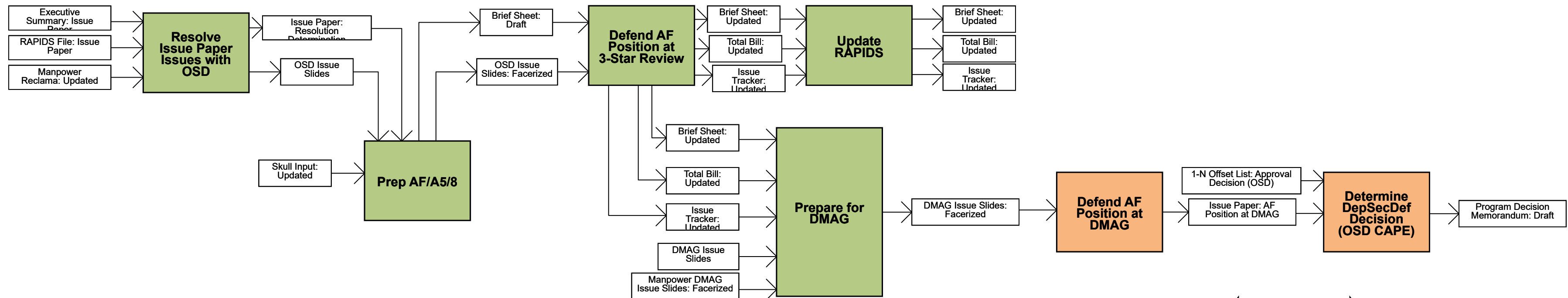

Note: If issue is resolved after the 3-Star Review, process ends after Updating Rapids. If issue is unresolved proceed to Prepare for DMAG and continue process until DepSecDef Decision.

BACK FWD



Acquisition Process Model

1.2.2.6.4 Respond to Initial PDM

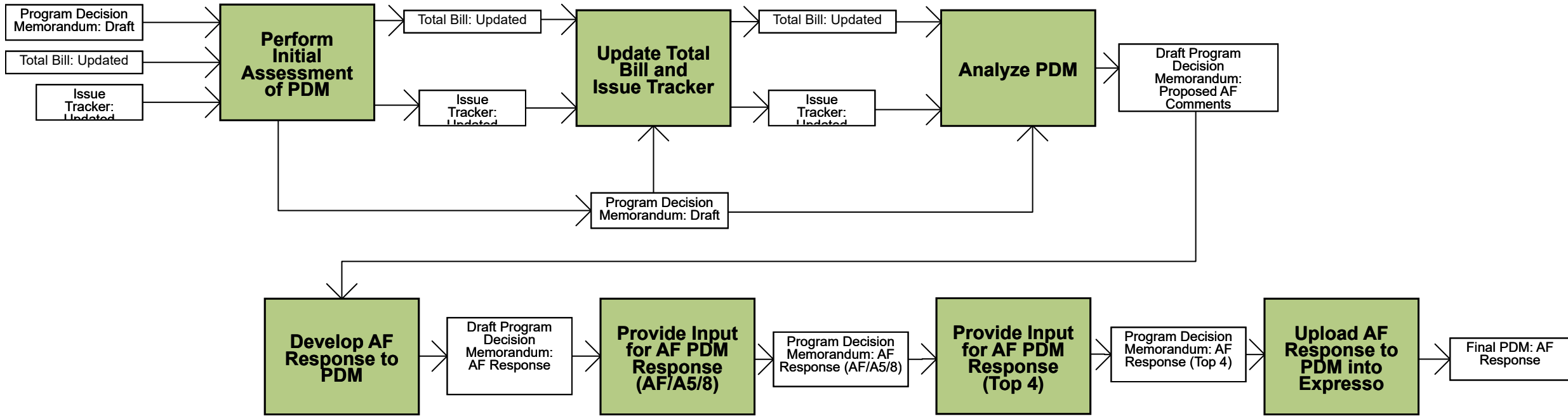

Go Up 1 Level

Acquisition Process Model

1.2.2.6.5 Process Final PDM

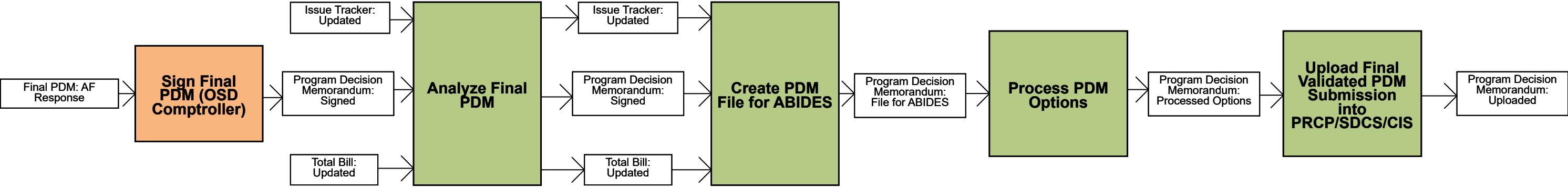

← BACK

Acquisition Process Model

1.2.2.7 Develop Offset List

Go Up 1 Level

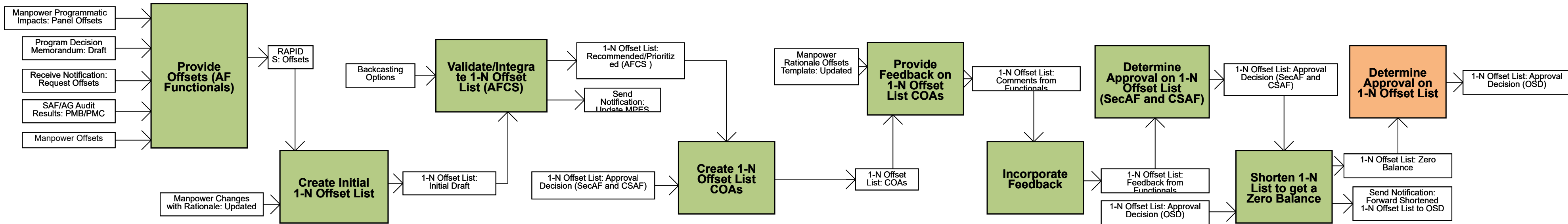

BACK

FWD

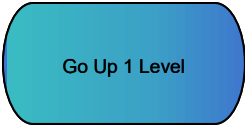

Acquisition Process Model

1.2.2.8 Conduct Logistics Requirements Determination Process

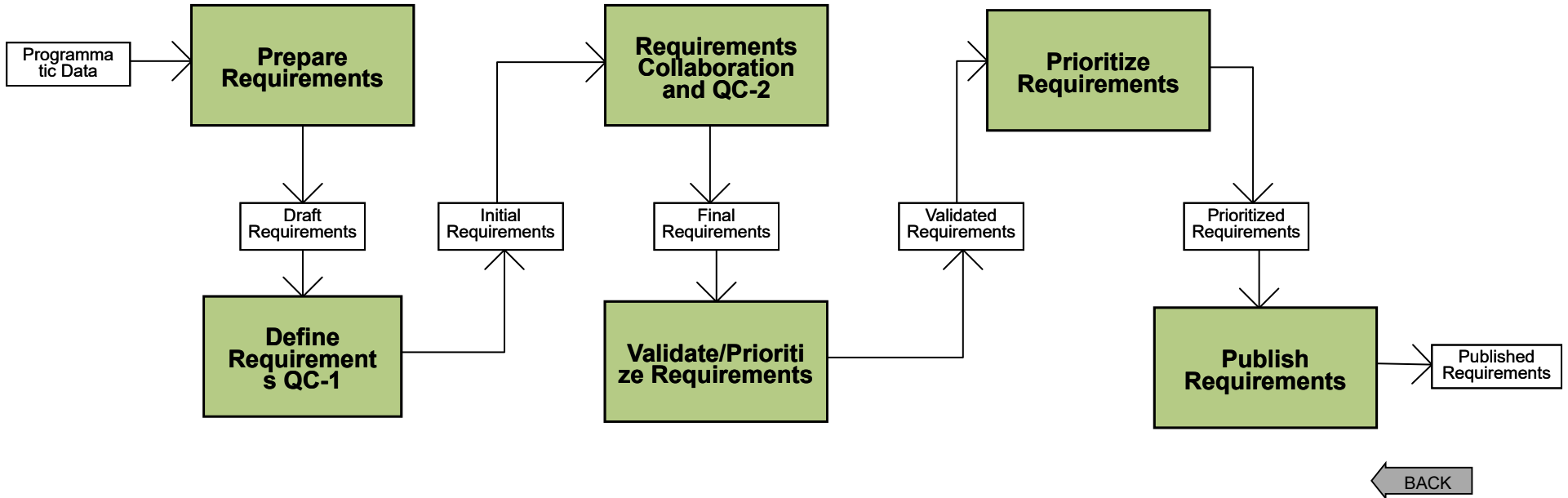

Go Up 1 Level

Acquisition Process Model

1.2.3 Conduct Budgeting

PEO View

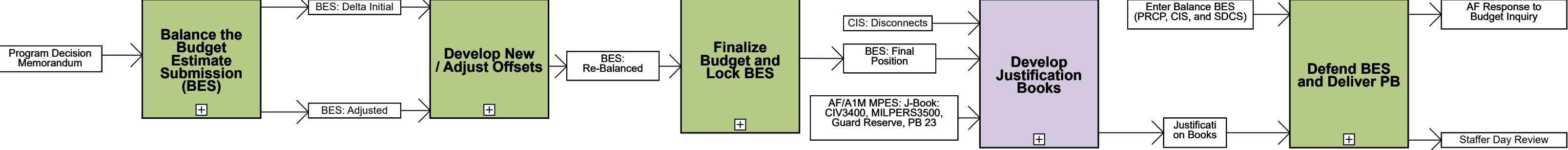

BACK

FWD

Acquisition Process Model

1.2.3.1 Balance the Budget Estimate Submission (BES)

Go Up 1 Level

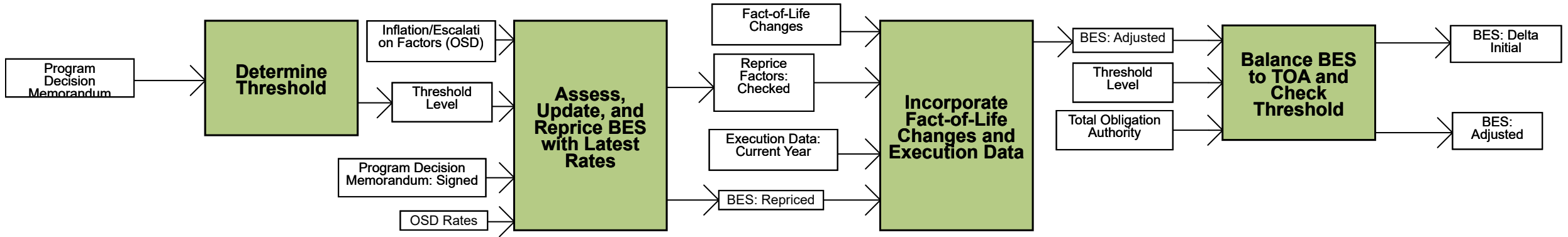

FWD

Go Up 1 Level

Acquisition Process Model

1.2.3.2 Develop New/Adjust Offsets

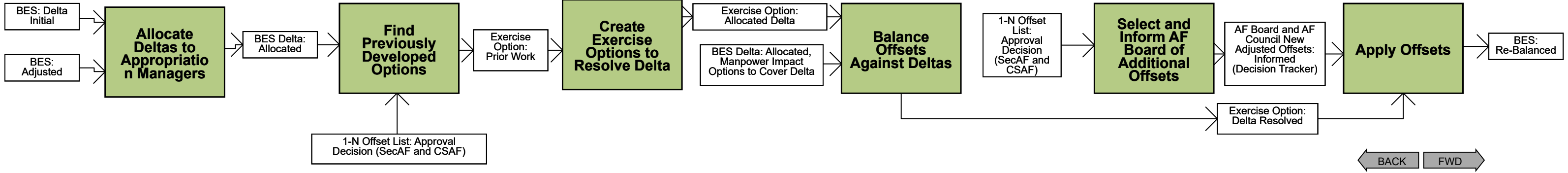

Go Up 1 Level

Acquisition Process Model

1.2.3.3 Finalize Budget and Lock BES

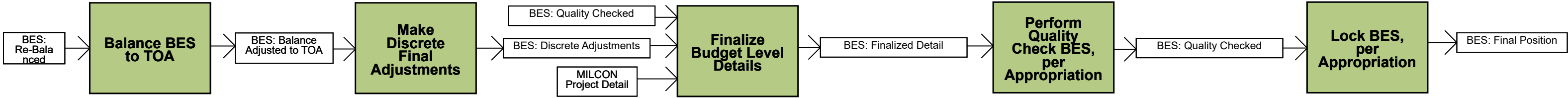

BACK FWD

Go Up 1 Level

Acquisition Process Model

1.2.3.4 Develop Justification Books

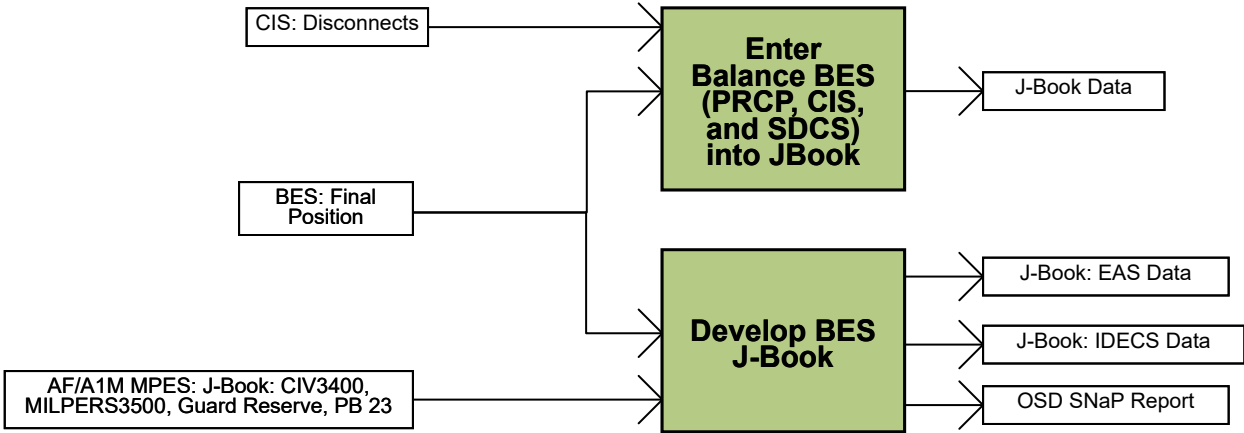

Note: The Program Budget Decision referenced in AFI 16-501 and the PPBE Reference Guide has been superseded by the Resource Management Decision.

← BACK

FWD →

Go Up 1 Level

Acquisition Process Model

1.2.3.5 Defend BES and Deliver PB

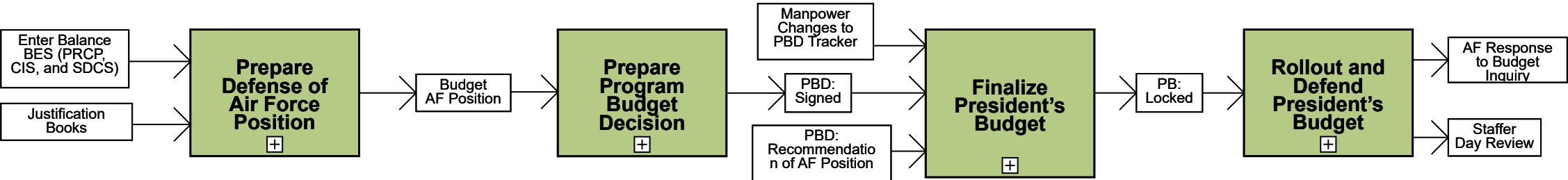

← BACK

Acquisition Process Model

1.2.3.5.1 Prepare Defense of Air Force Position

Go Up 1 Level

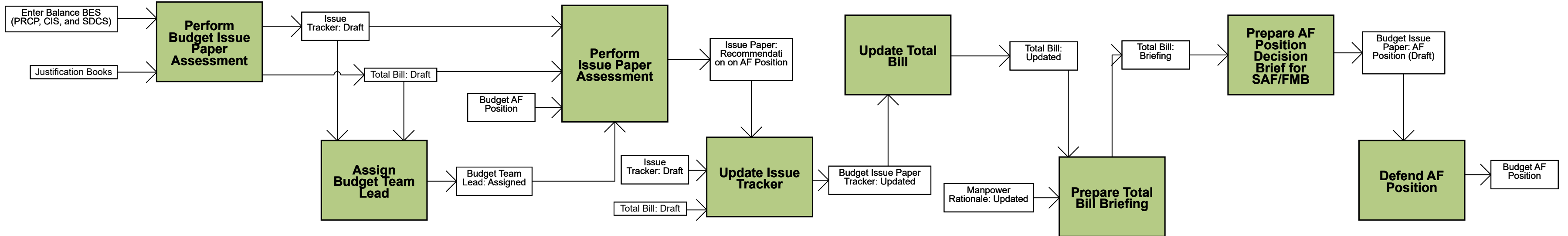

FWD

Acquisition Process Model

1.2.3.5.2 Prepare Program Budget Decision

Go Up 1 Level

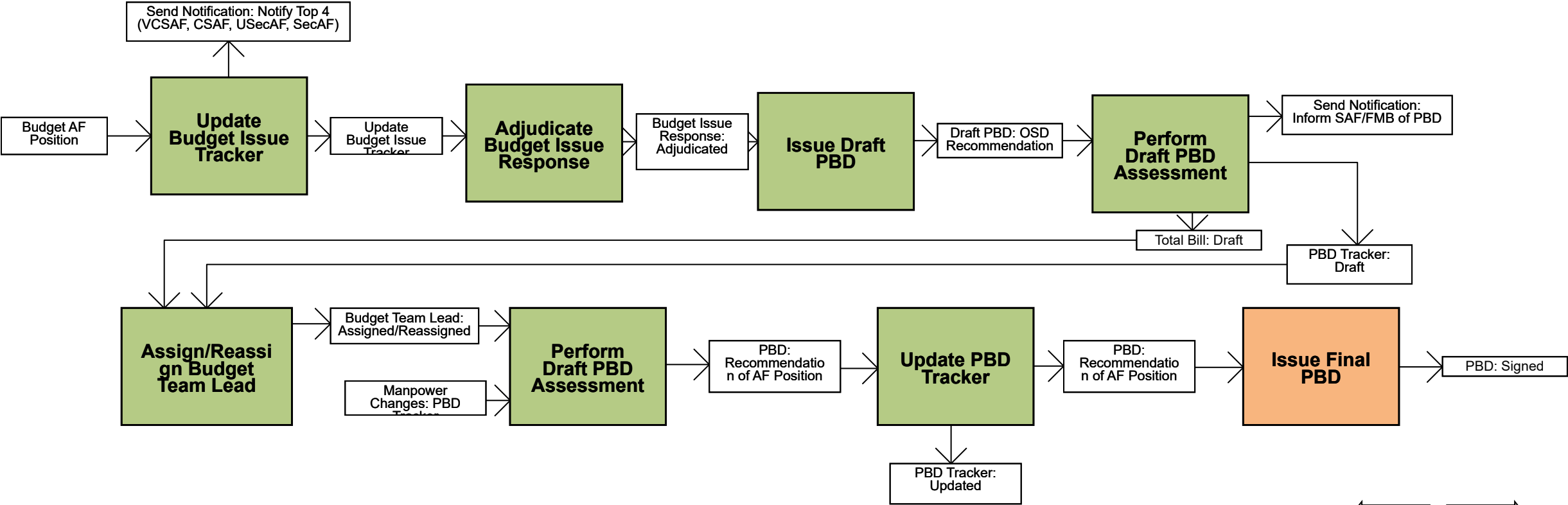

← BACK
FWD →

Go Up 1 Level

Acquisition Process Model

1.2.3.5.3 Finalize President's Budget

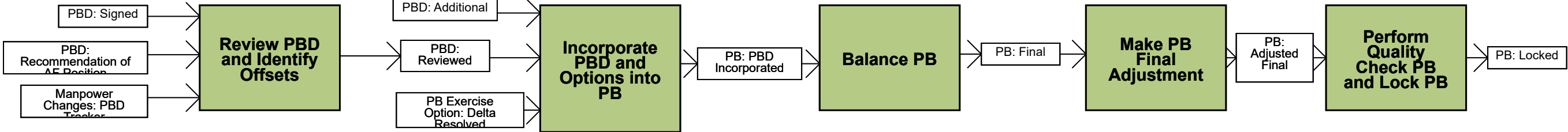

← BACK

FWD →

Go Up 1 Level

Acquisition Process Model

1.2.3.5.4 Rollout and Defend President's Budget

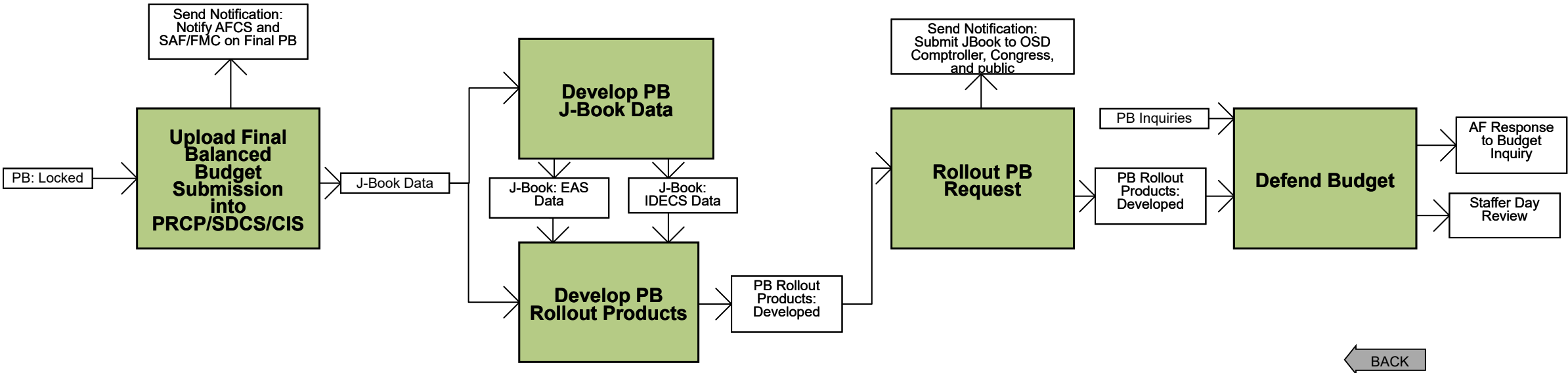

Go Up 1 Level

Acquisition Process Model

1.2.4 Conduct Financial Execution

PEO View

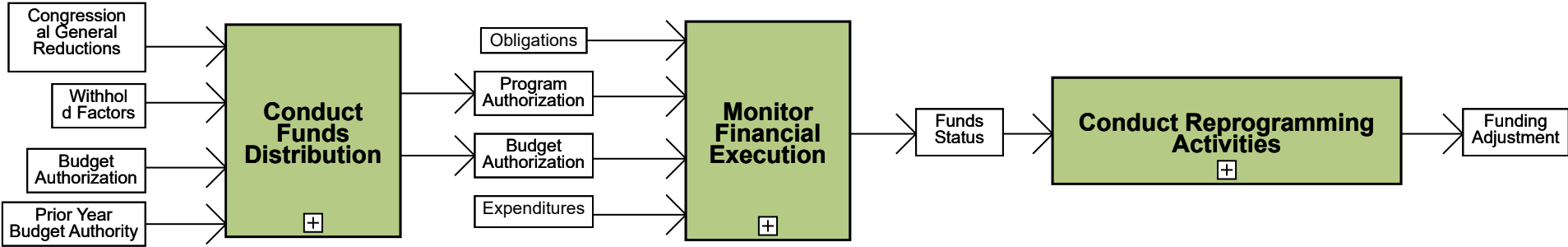

← BACK

Go Up 1 Level

Acquisition Process Model

1.2.4.1 Conduct Funds Distribution

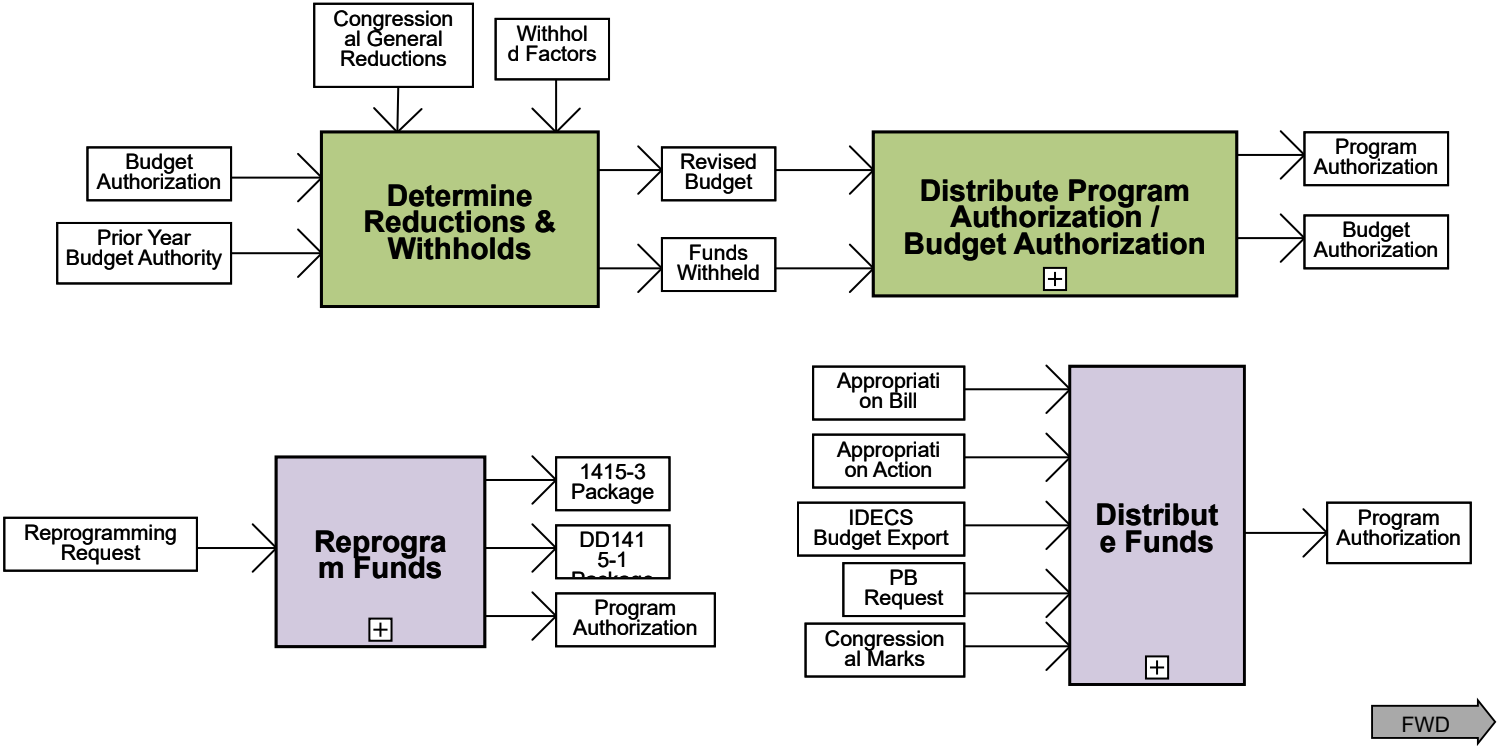

Go Up 1 Level

Acquisition Process Model

1.2.4.1.2 Distribute Program Authorization and Budget Authorization

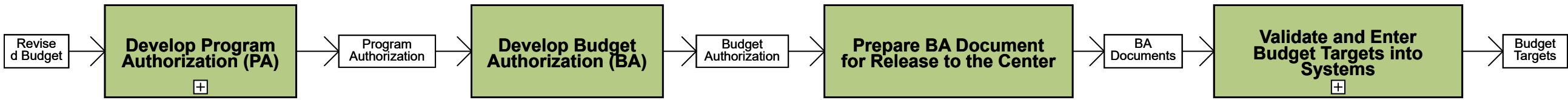

Note: The final process above is an AFLCMC Standard Process.

FWD

Acquisition Process Model

1.2.4.1.2.1 Develop Program Authority

Go Up 1 Level

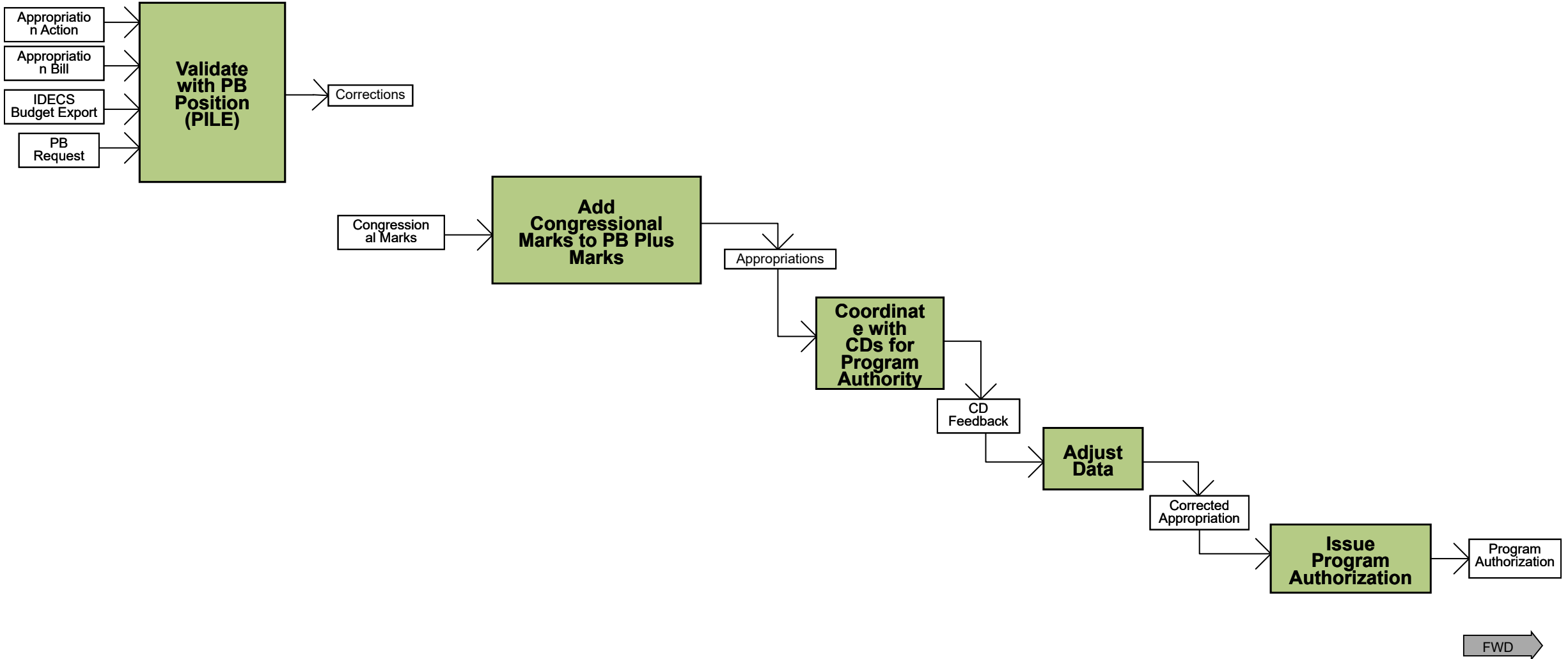

Go Up 1 Level

Acquisition Process Model

1.2.4.1.2.4 Validate and Enter Budget Targets into Systems

AFLCMC Standard Processes

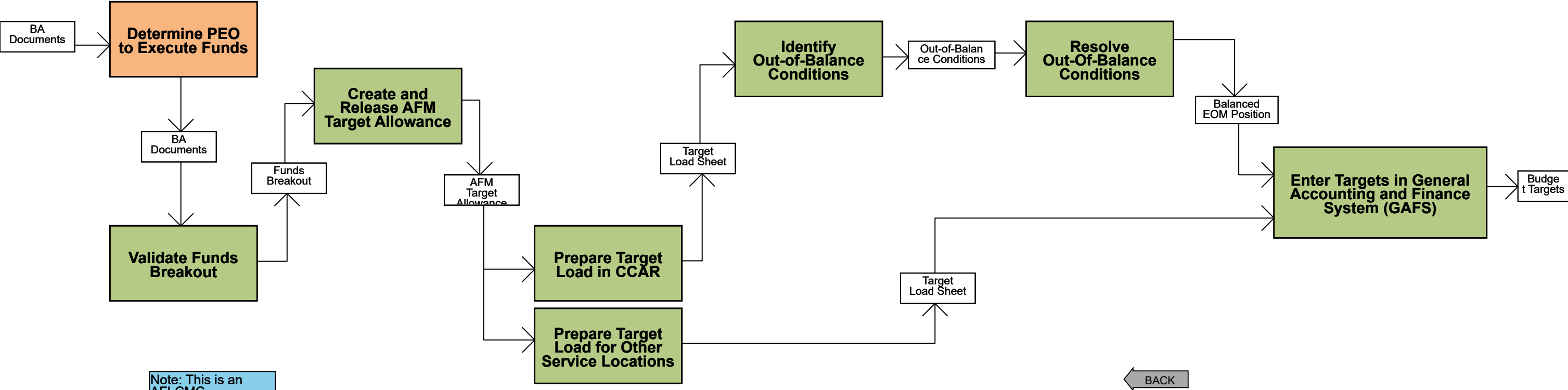

Note: This is an AFLCMC Standard Process.

Go Up 1 Level

Acquisition Process Model

1.2.4.1.3 Reprogram Funds

PEO View

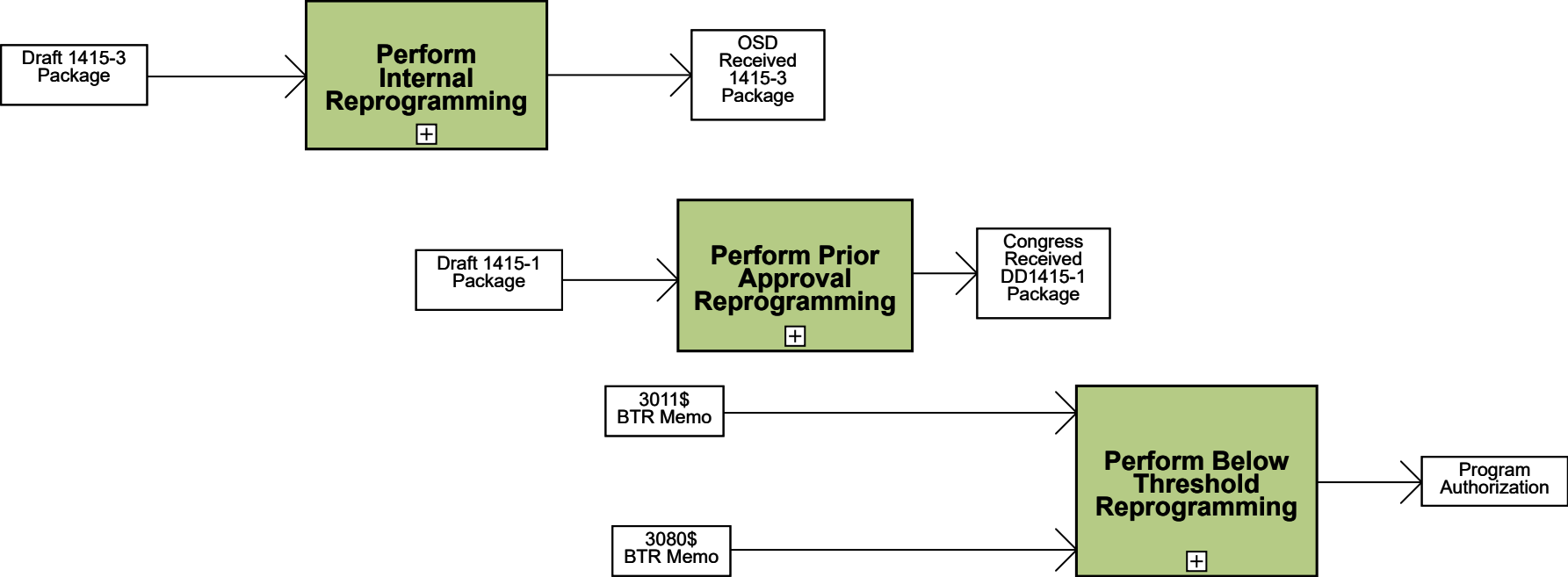

BACK FWD

Go Up 1 Level

Acquisition Process Model

1.2.4.1.3.1 Perform Internal Reprogramming

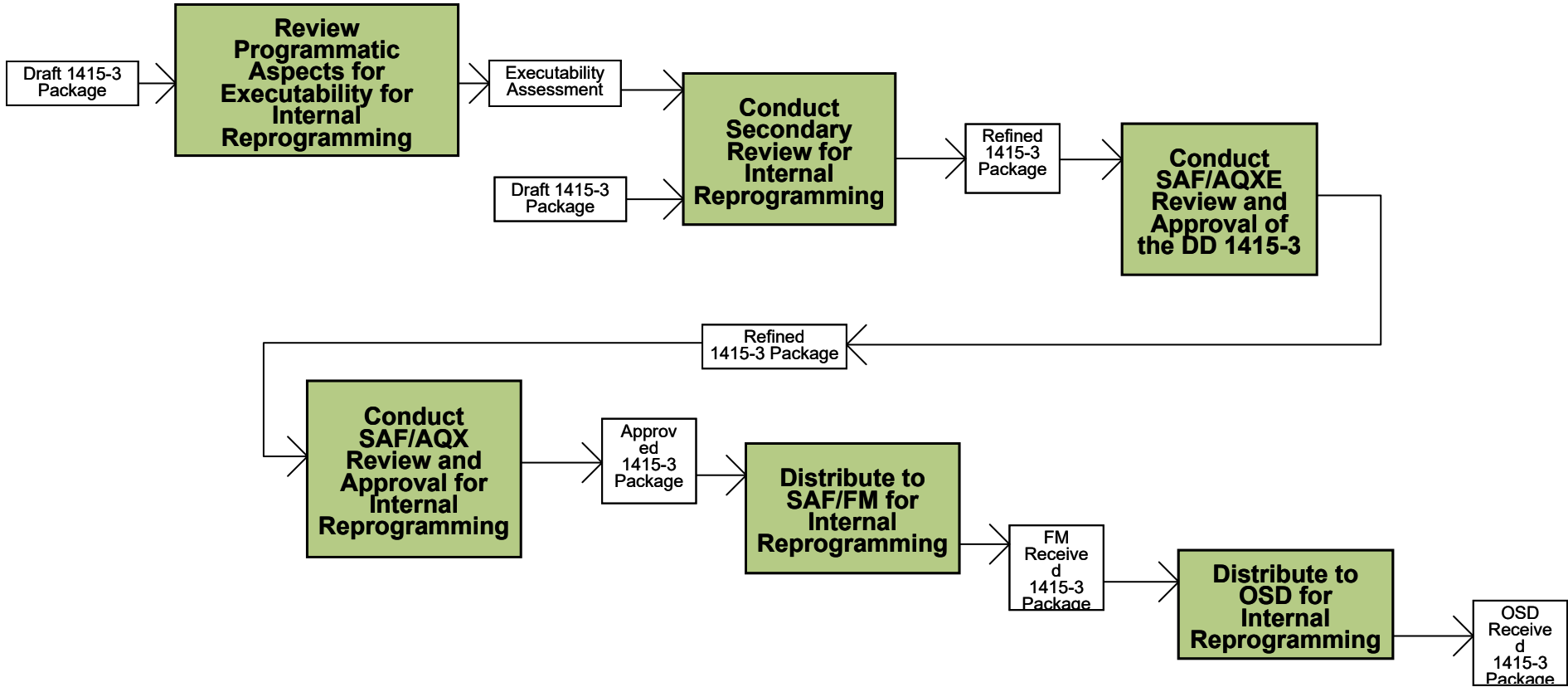

FWD

Go Up 1 Level

Acquisition Process Model

1.2.4.1.3.2 Perform Prior Approval Reprogramming

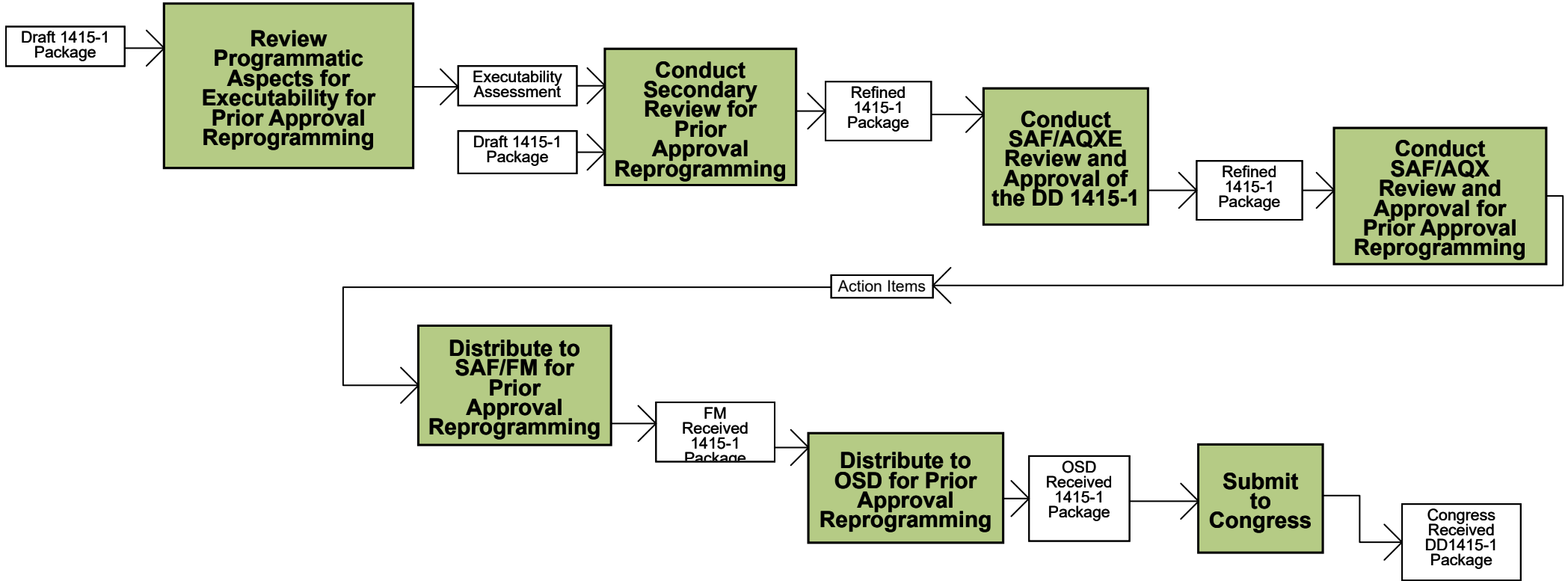

BACK FWD

Go Up 1 Level

Acquisition Process Model

1.2.4.1.3.3 Perform Below Threshold Reprogramming

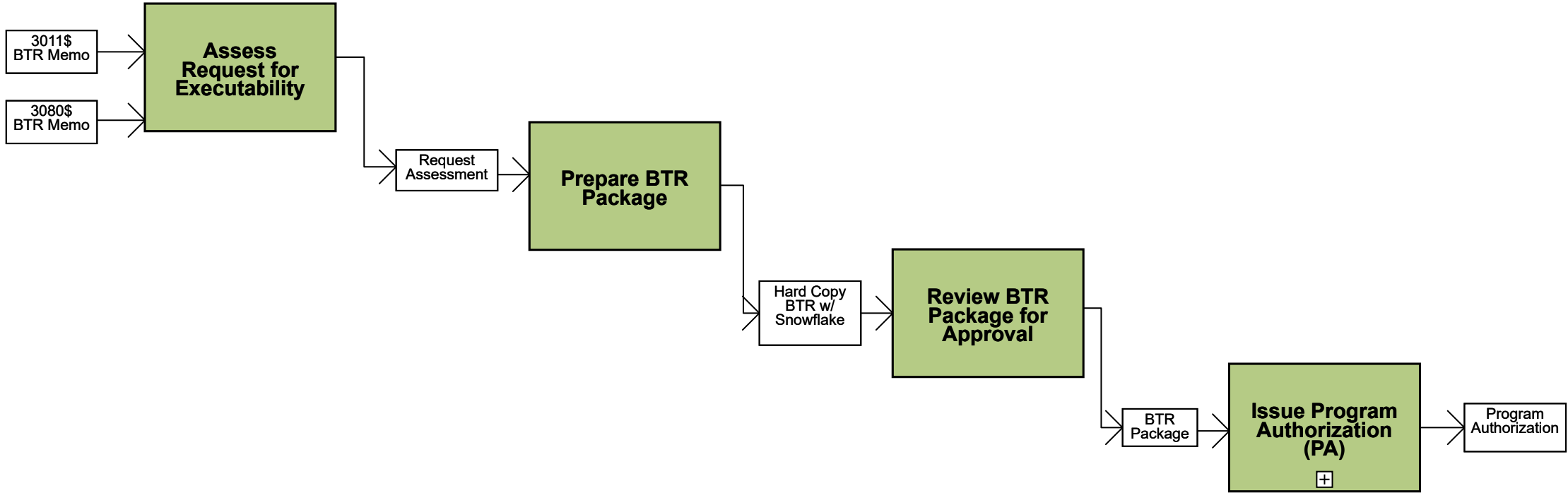

← BACK



Acquisition Process Model

1.2.4.1.3.3.4 Issue Program Authorization - PA

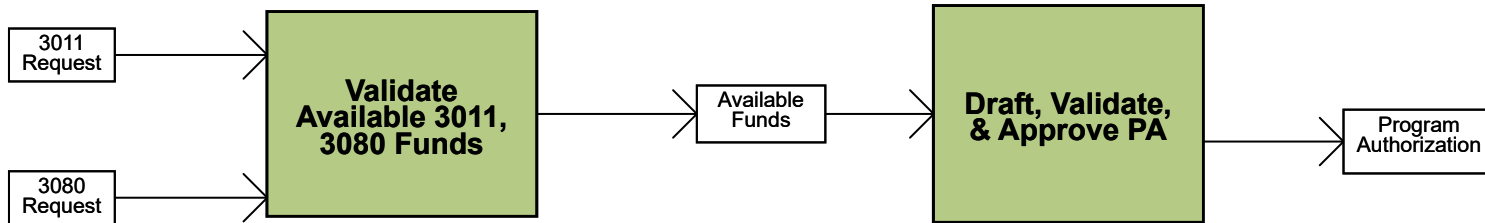

Go Up 1 Level

Acquisition Process Model

1.2.4.1.4 Distribute Funds

PEO View

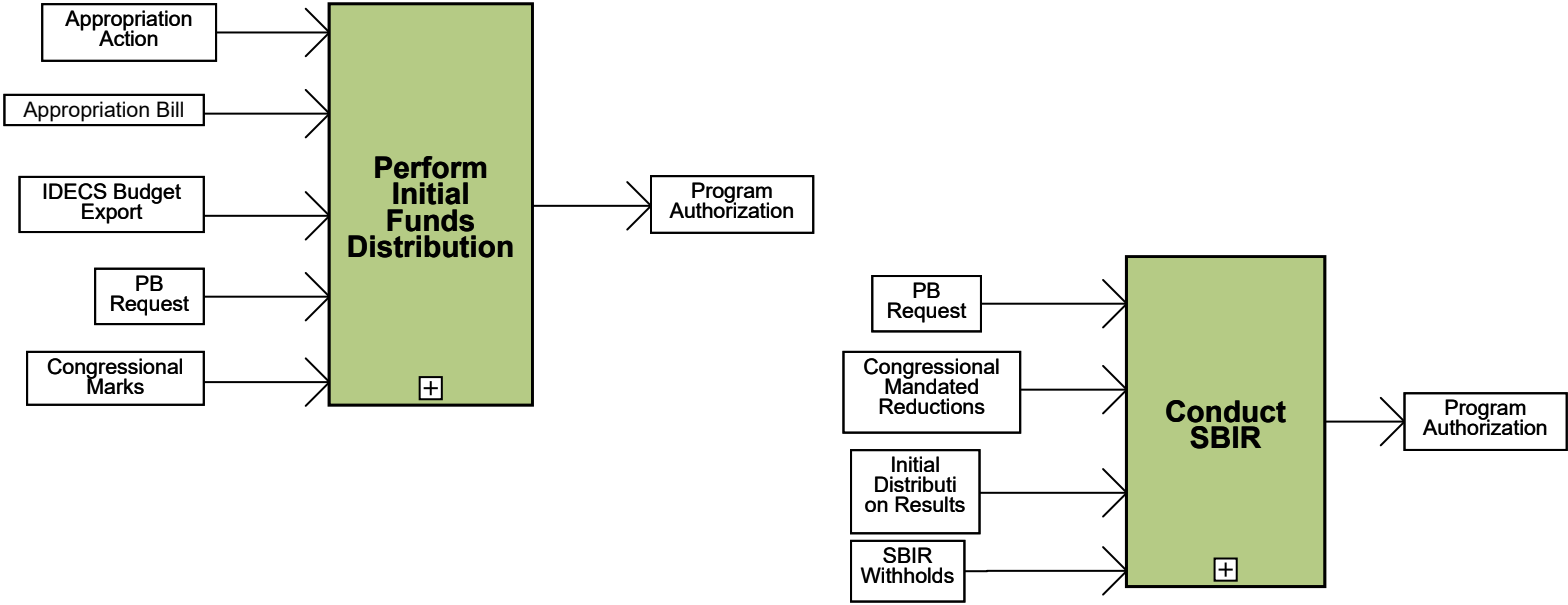

← BACK

Go Up 1 Level

Acquisition Process Model

1.2.4.1.4.1 Perform Initial Distribution

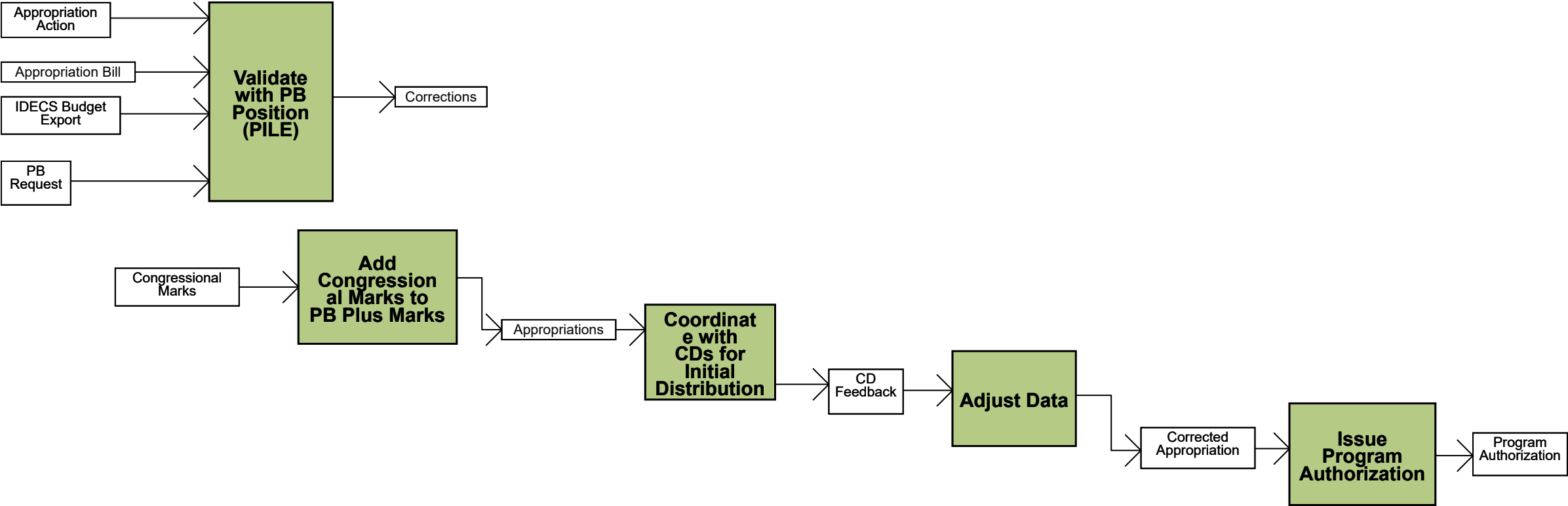

FWD

Go Up 1 Level

Acquisition Process Model

1.2.4.1.4.2 Conduct SBIR

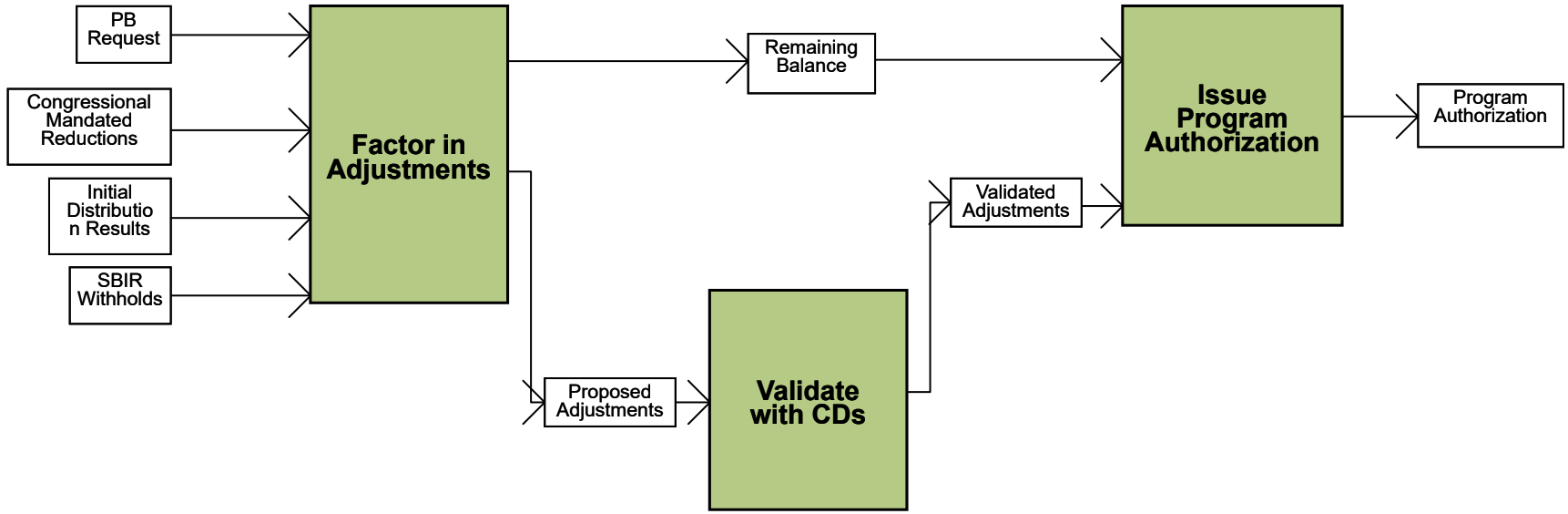

← BACK

Go Up 1 Level

Acquisition Process Model

1.2.4.2 Monitor Financial Execution

PEO View

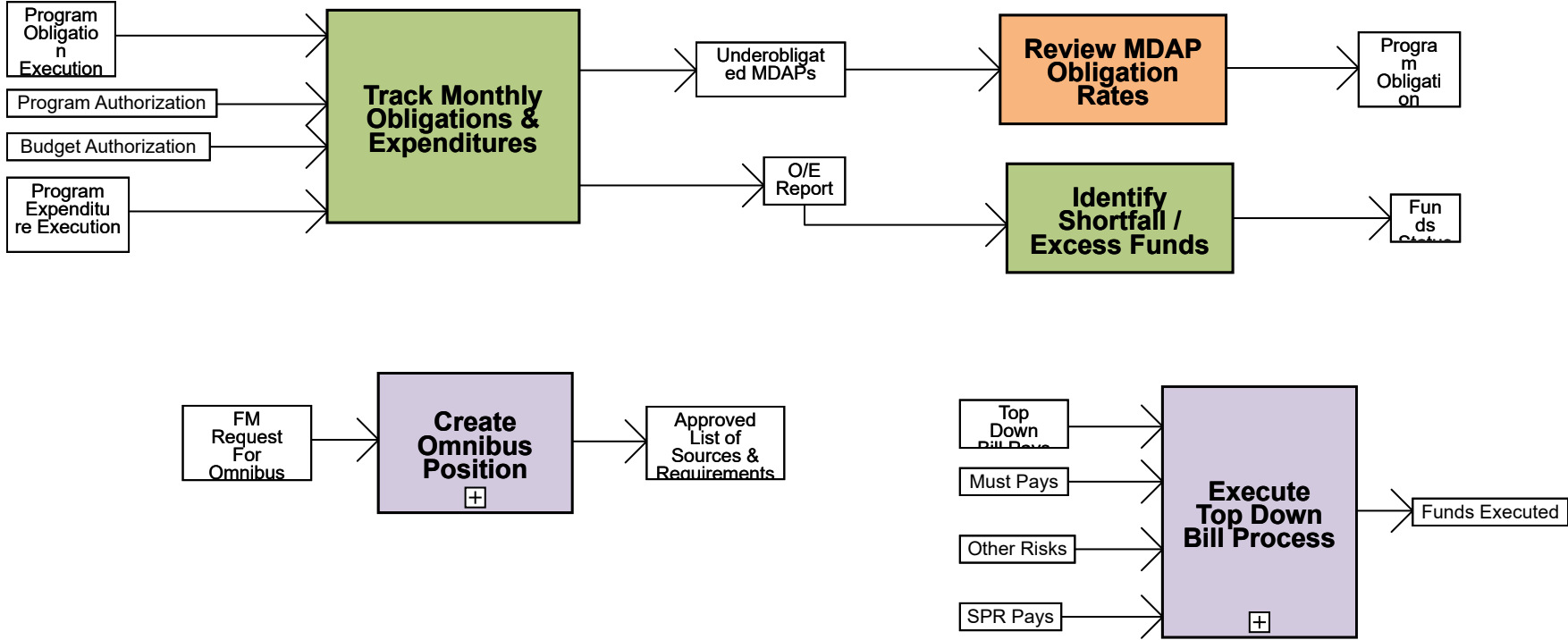

Note: Click here to access an active link to a memo from Mr. Hale and Mr. Kendall regarding obligation rate tenets.

← BACK FWD →

Go Up 1 Level

Acquisition Process Model

1.2.4.2.3 Create Omnibus Position

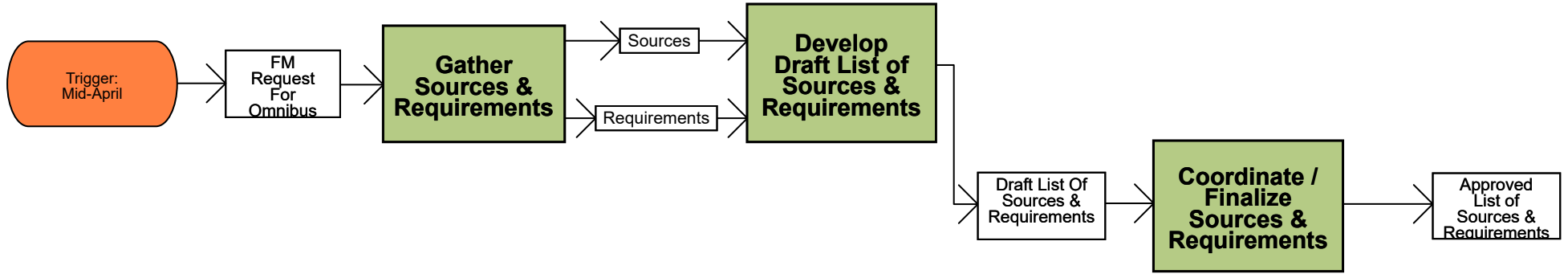

FWD

Go Up 1 Level

Acquisition Process Model

1.2.4.2.4 Execute Top Down Bill Process

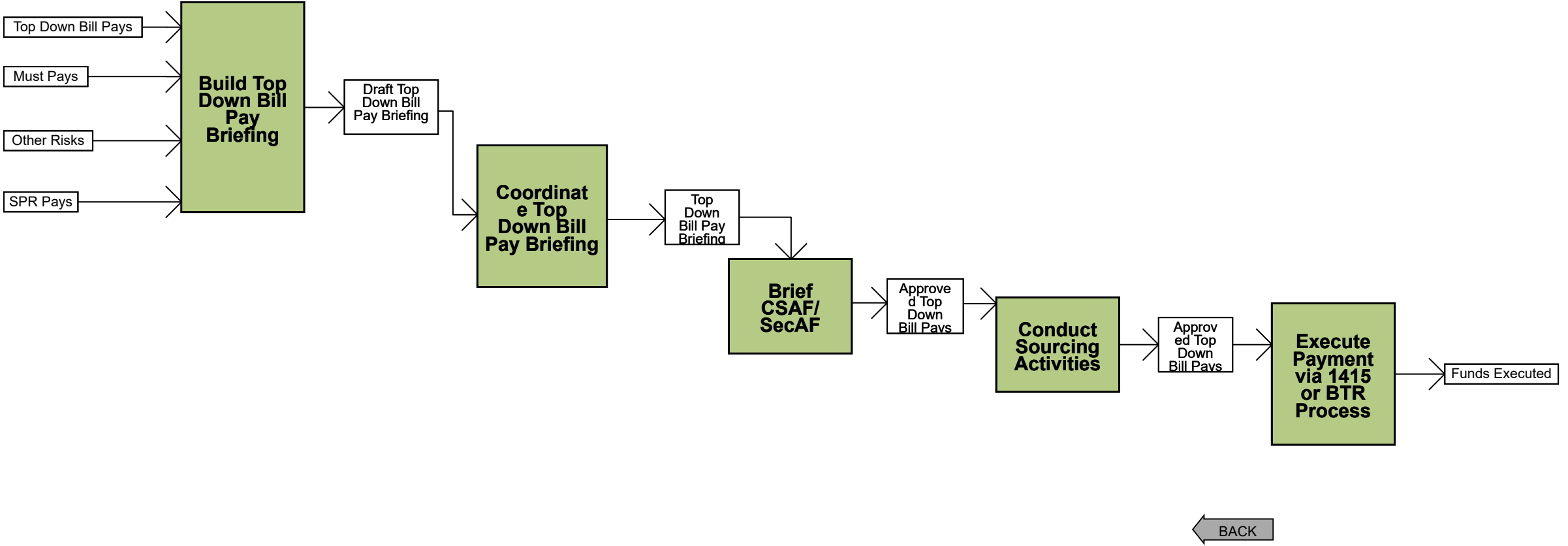

Go Up 1 Level

Acquisition Process Model

1.2.4.3 Conduct Reprogramming Activities

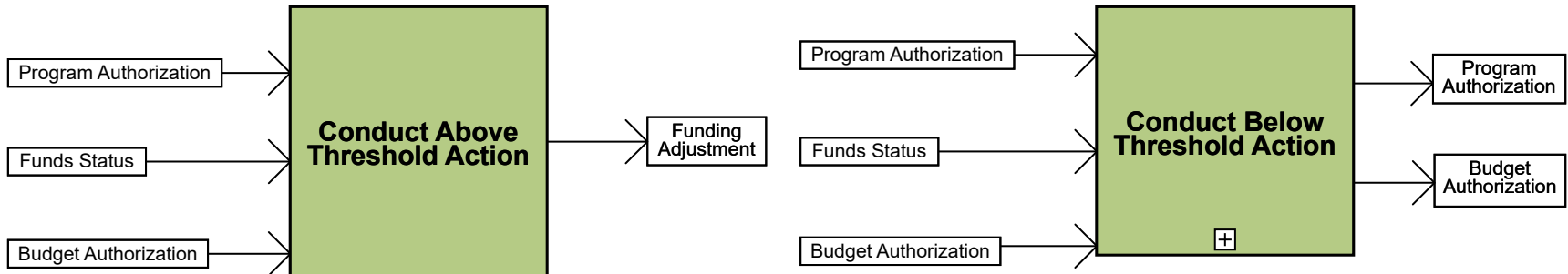

← BACK

Go Up 1 Level

Acquisition Process Model

1.2.4.3.2 Conduct Below Threshold Action

AFLCMC Standard Processes

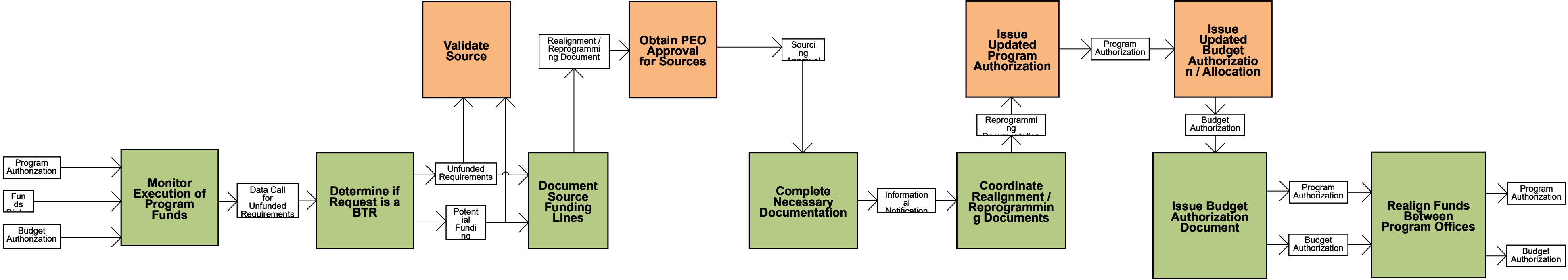

FWD

Acquisition Process Model

1.2.4.3.3 Review and Coordinate Program Baselines

Go Up 1 Level

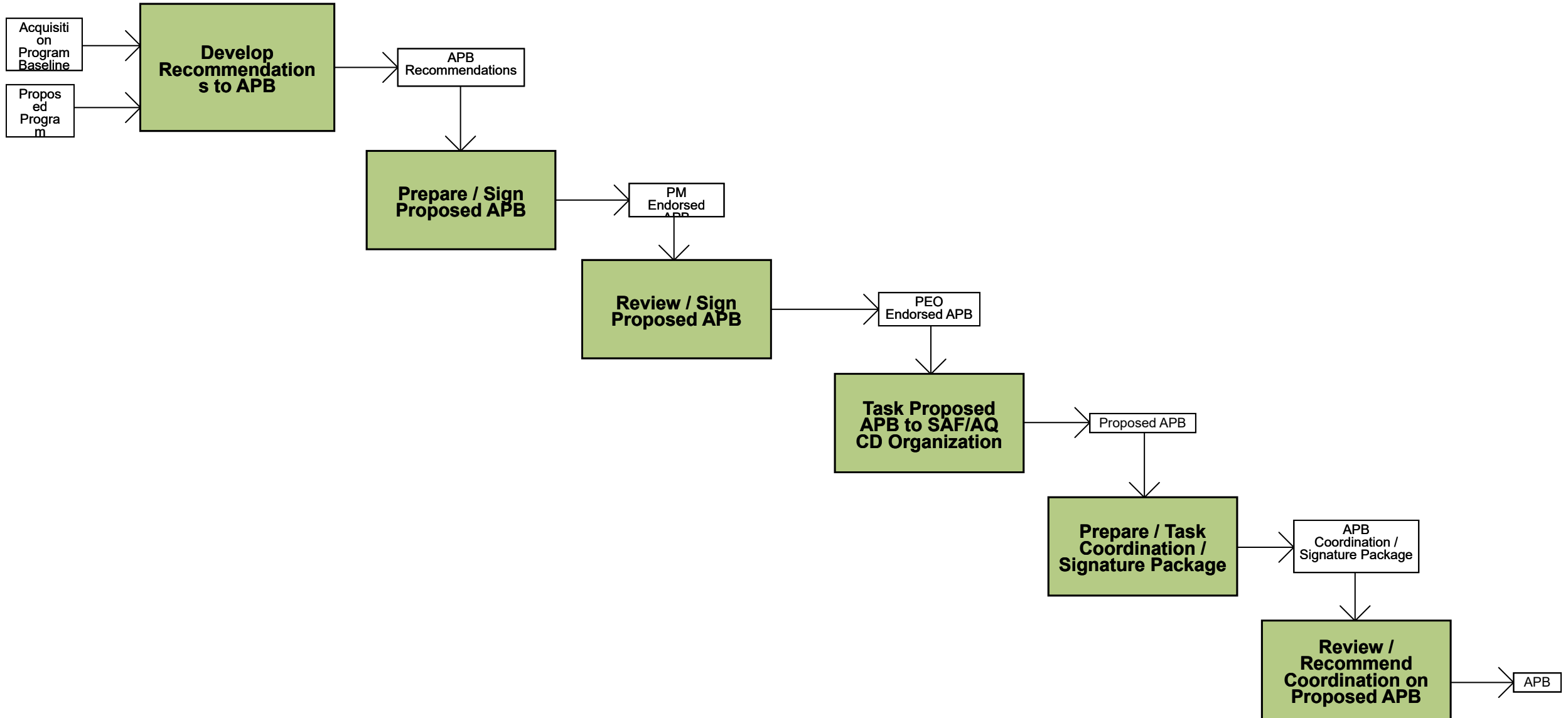

← BACK FWD →

Go Up 1 Level

Acquisition Process Model

1.2.4.3.4 Provide General Equipment Valuation - Government Furnished Equipment Data

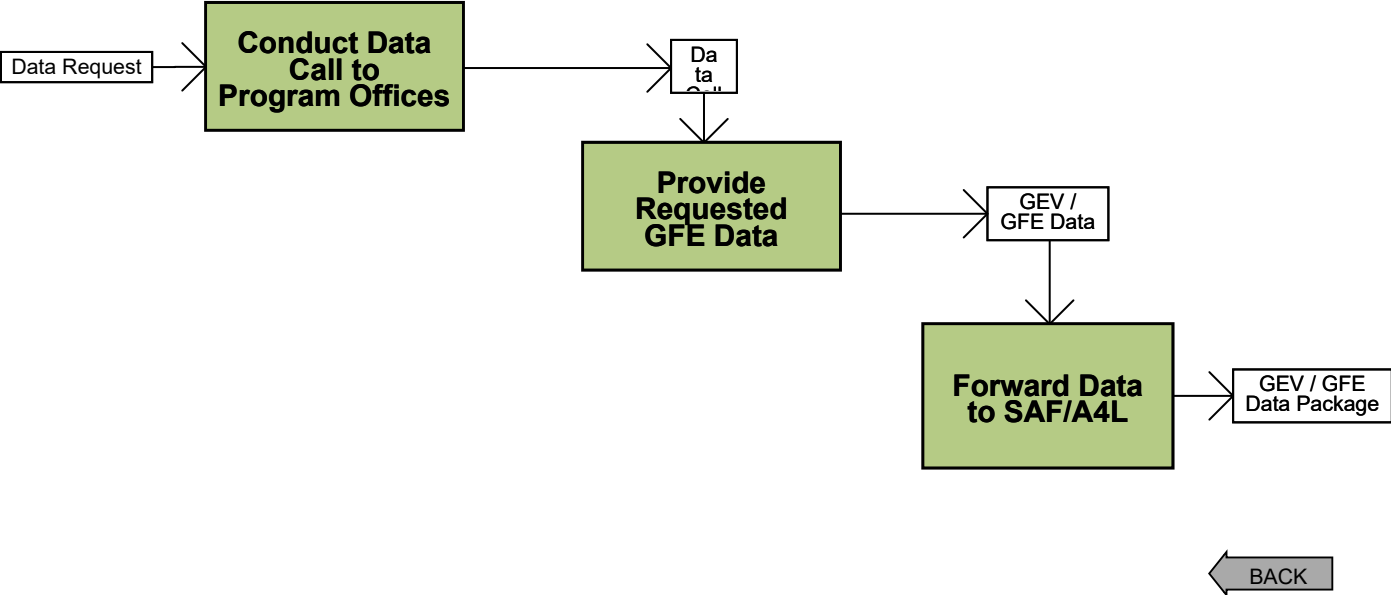

Go Up 1 Level

Acquisition Process Model

1.3 Develop Requirements and Preliminary Design

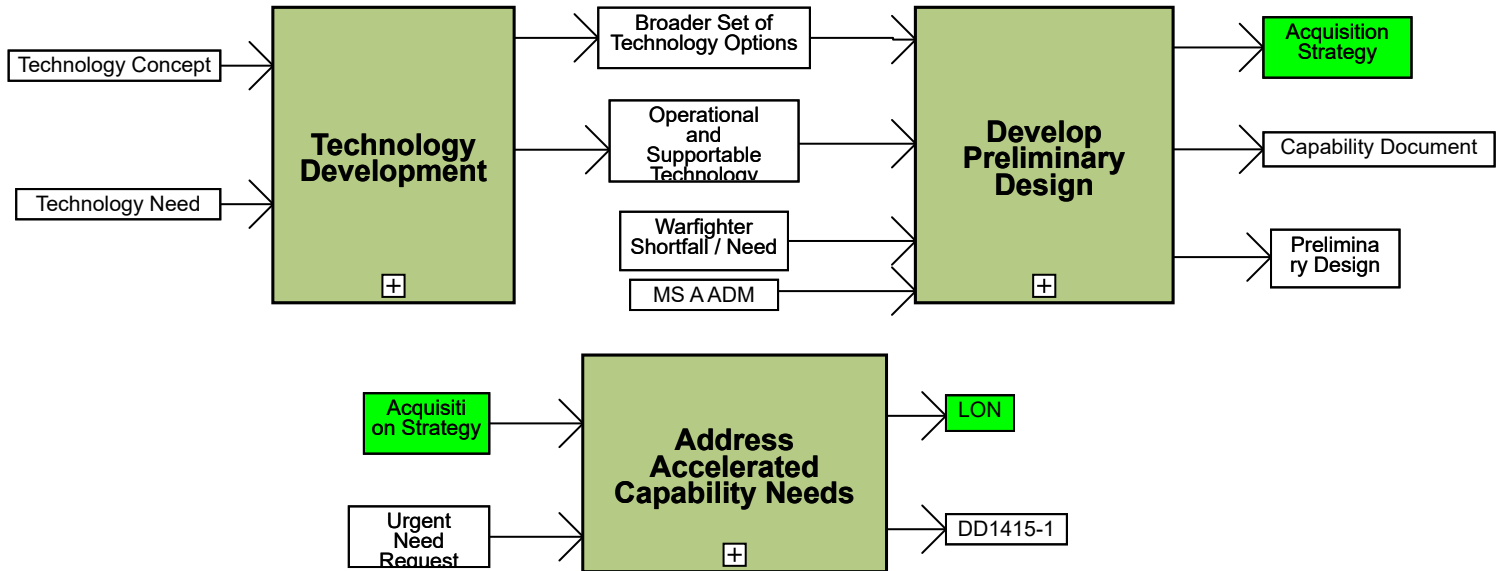

Note 1 from the Chief Process Officer: The Under Secretary of Defense for AT&L has provided four key enduring acquisition principles. The first of these principles is "Think". Program managers should tailor the program according to the specific needs of that program. The rote checking the blocks in a checklist or simply following each and every step of a process is the antithesis of Mr Kendall's challenge to Program Managers. Use this Model as a model. If your program's situation warrants a waiver from the checklist or process, seek that waiver from your milestone decision authority. Click here to access an active link to Mr. Kendall's thoughts.

Note 2: The purpose of program tailoring is to streamline the acquisition program to the maximum extent possible, consistent with risk, to provide new systems to operational commanders as fast as possible. DoDI 5000.02, Section 5.a.2; AFPAM 63-128, Section 14.1

← BACK
FWD →

Go Up 1 Level

Acquisition Process Model

1.3.1 Technology Development

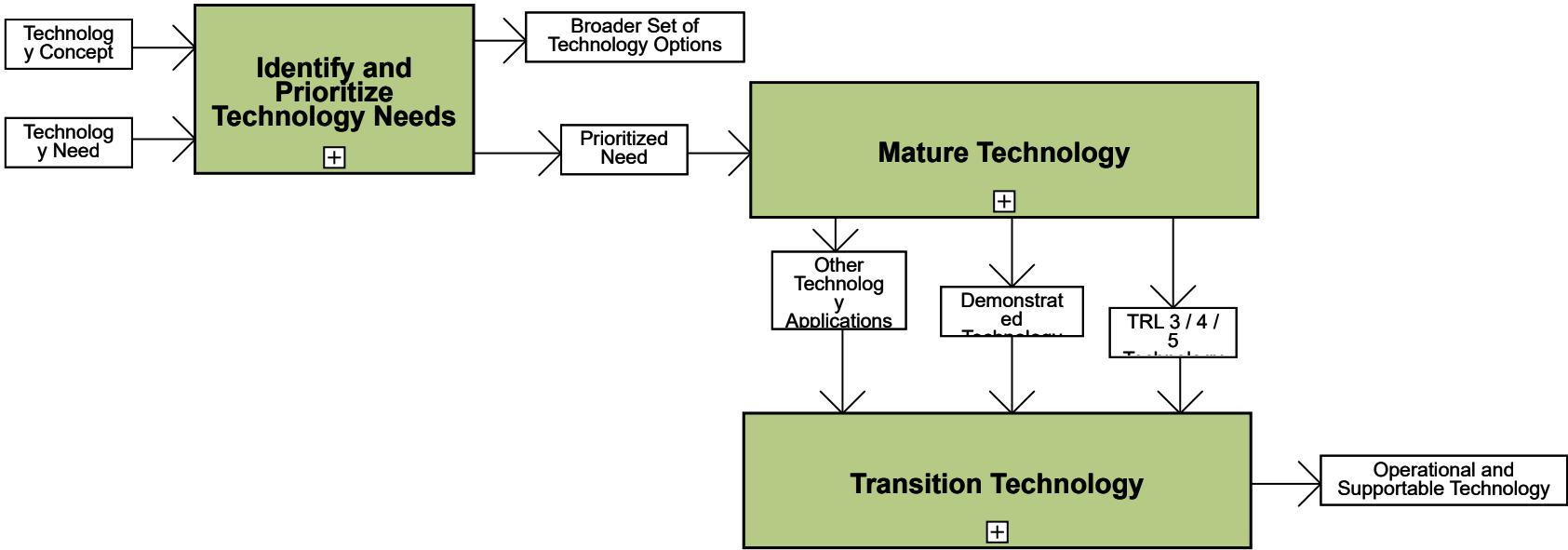

FWD

Go Up 1 Level

Acquisition Process Model

1.3.1.1 Identify and Prioritize Technology Needs

PEO View

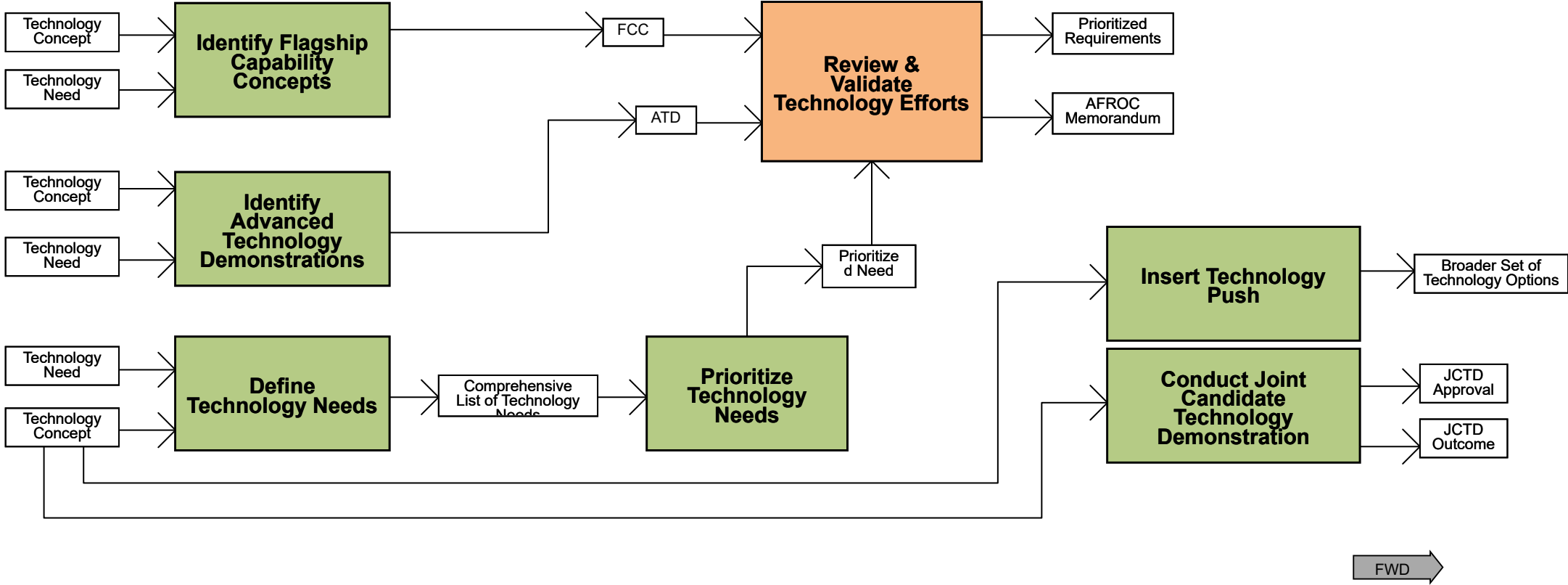

Go Up 1 Level

Acquisition Process Model

1.3.1.2 Mature Technology

PEO View

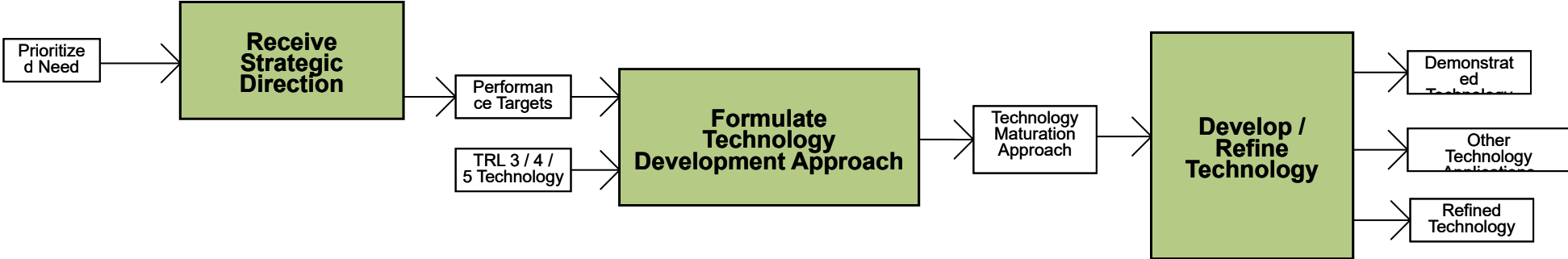

BACK

FWD

Go Up 1 Level

Acquisition Process Model

1.3.1.3 Transition Technology

PEO View

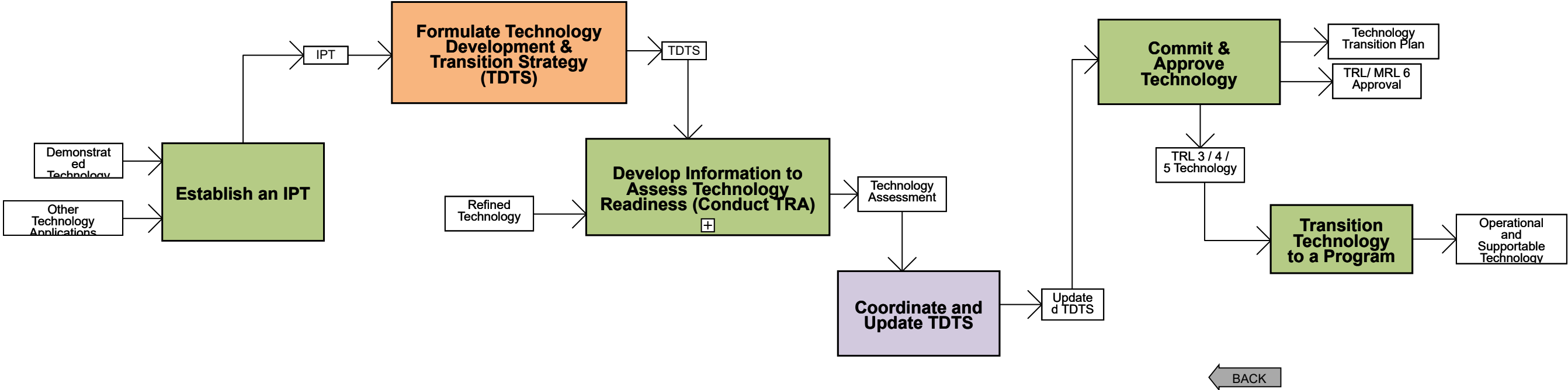

Acquisition Process Model

1.3.1.3.3 Develop Information to Assess Technology

Go Up 1 Level

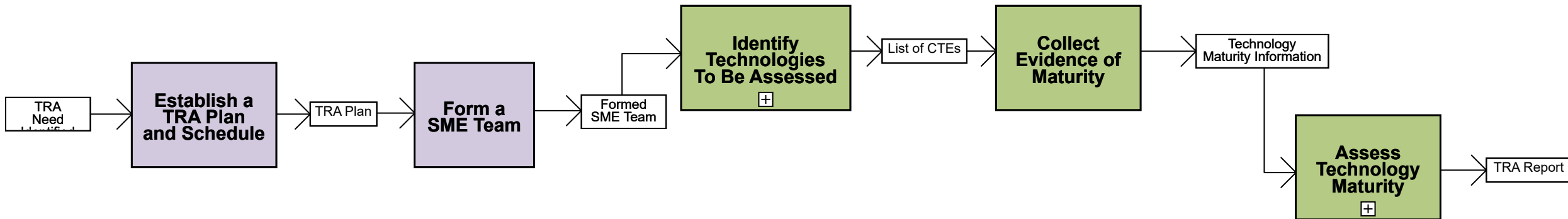

Go Up 1 Level

Acquisition Process Model

1.3.1.3.3.3 Identify Technologies to be Assessed

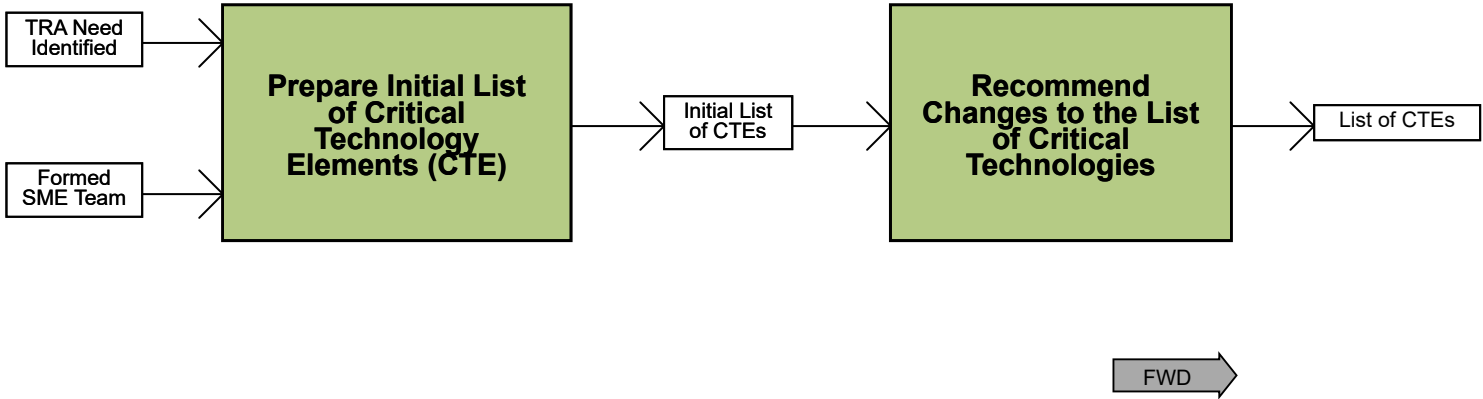

Acquisition Process Model

1.3.1.3.3.5 Assess Technology Maturity

Go Up 1 Level

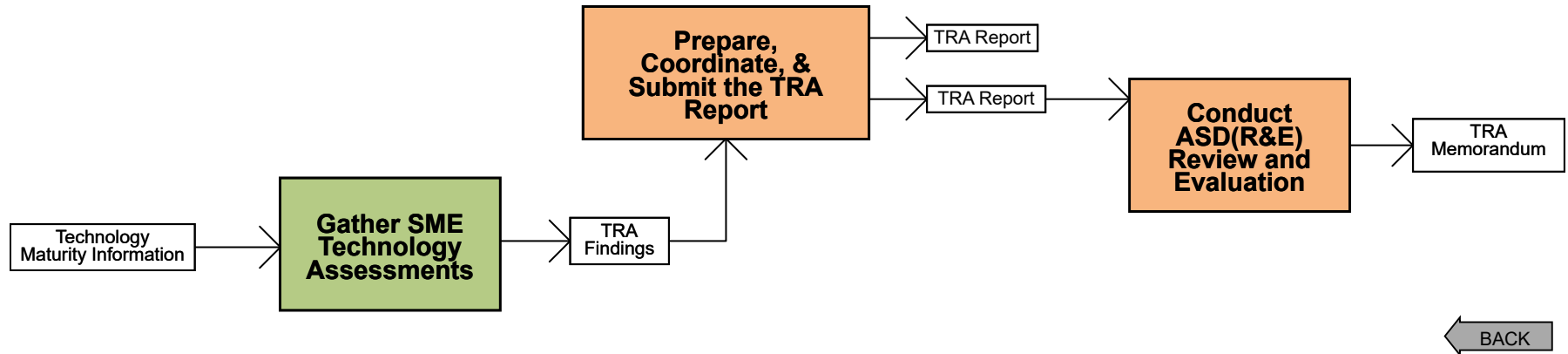

Acquisition Process Model

1.3.2 Develop Preliminary Design

PEO View

Go Up 1 Level

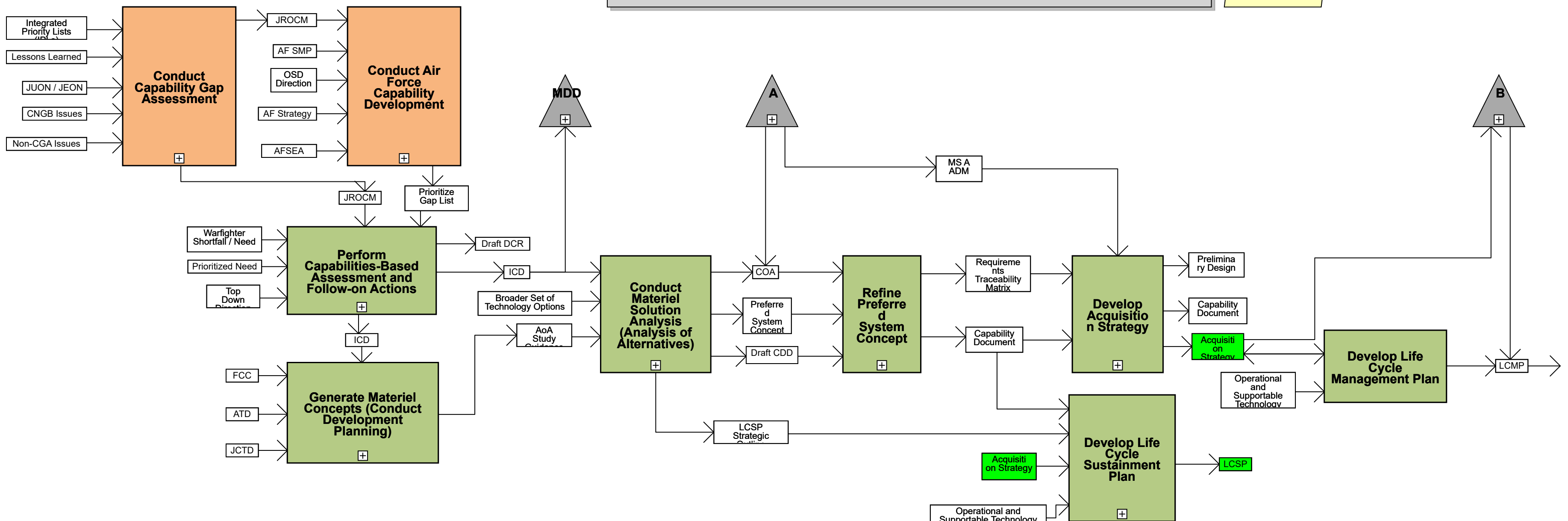

Note 1: The following websites provide valuable information for product support activities. The DoD Integrated Product Support Implementation Roadmap has links to over 2500 knowledge items (such as policy, references, and continuous learning modules). The Roadmap identifies activities and outputs for the twelve integrated product support (IPS) elements over the total life cycle. DoD has also established a Product Support Manager website that provides links to a variety of relevant documents. Finally, the Air Force has developed the Contract Sustainment Support Guide to provide best practices for contractor logistics support. Click here to access an active link to each of the above.

Note 2: This enabling process is based on the AFMC/EN and SMC/EN sponsored SEAM Guide.

Note 3: The Conduct Air Force Capability Development process provides direction to and is informed by the Pre-Milestone A processes on this page.

Note 4: Enclosure 14, Sections 4 and 7 of DoDI 5000.02 provide a list of actions that RDT&E Organizations / Program Managers should take relative to Cybersecurity. Click here to access an active link to the instruction.

Note 5: Consistent with the 24 Apr 13 Implementation Directive for Better Buying Power 2.0, Defense Exportability must be considered in the acquisition process. Such considerations must be incorporated in acquisition planning efforts. Click here to access an active link to the Implementation Directive.

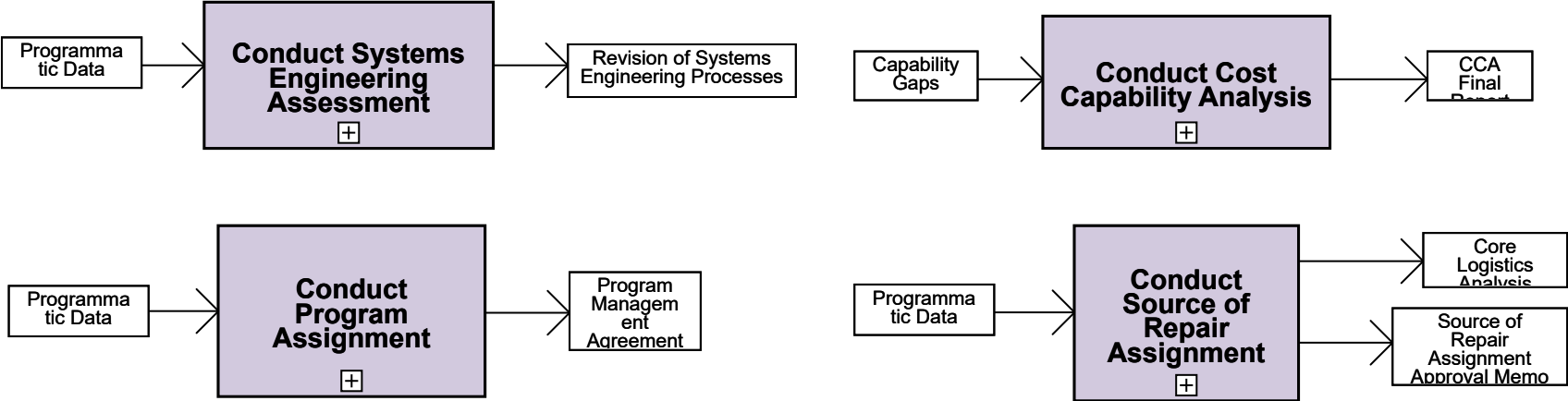

← BACK FWD →

Go Up 1 Level

Acquisition Process Model

1.3.2.1 Perform Capabilities-Based Assessment

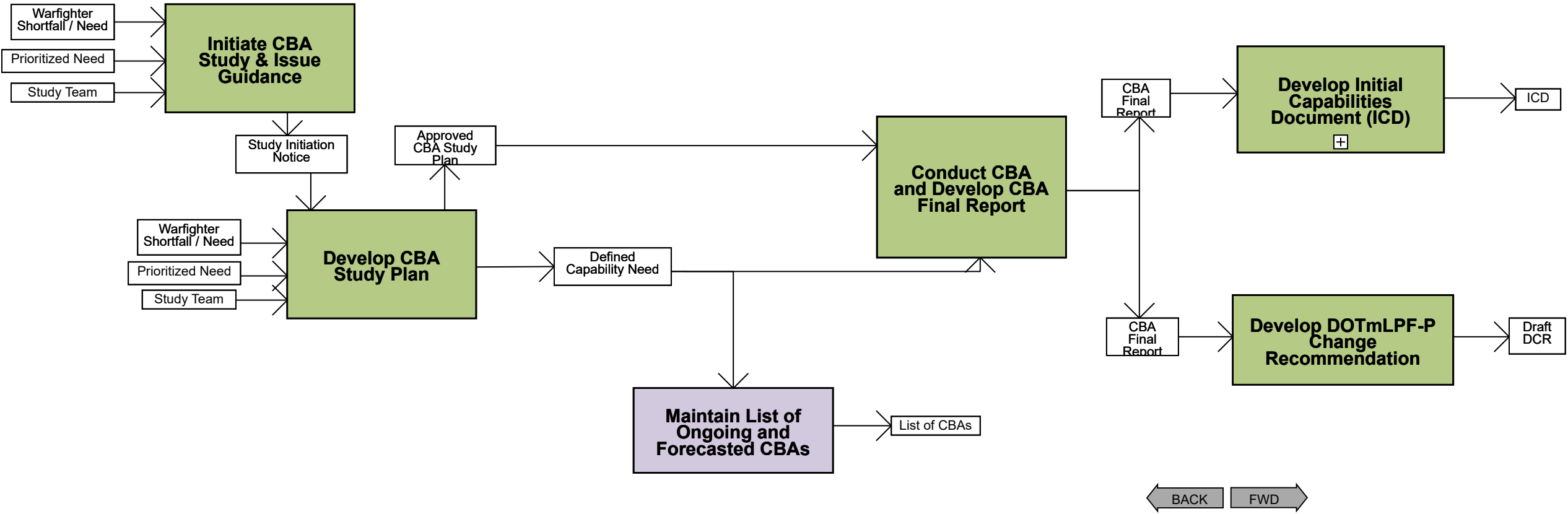

Go Up 1 Level

Acquisition Process Model

1.3.2.1.4 Develop Initial Capabilities Document (ICD)

PEO View

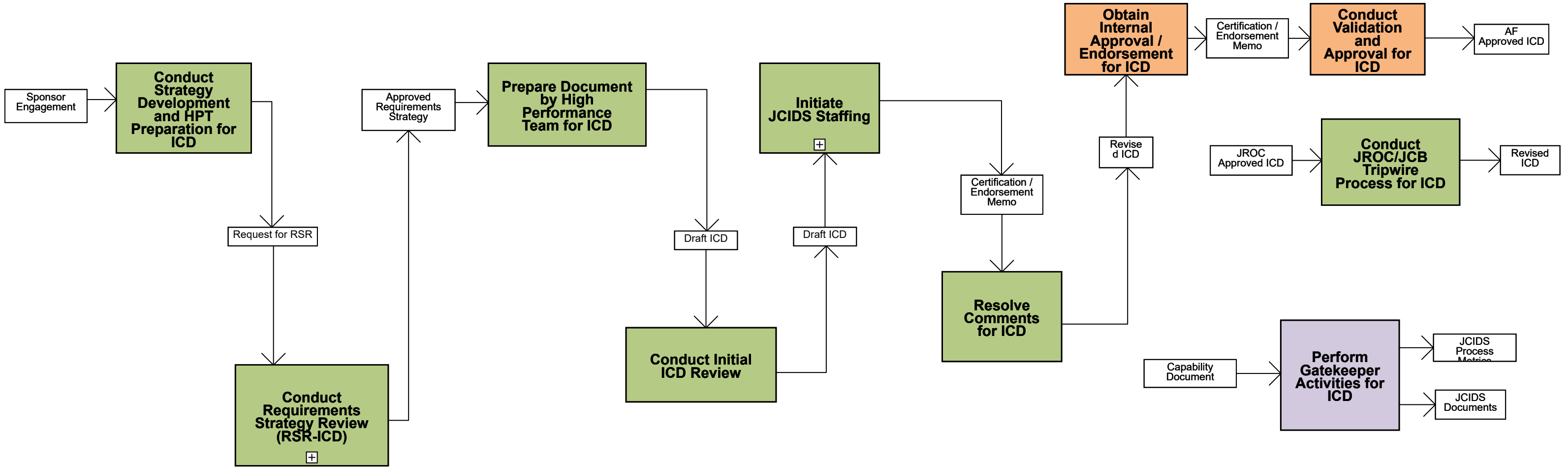

Note 1: The following KPPs are mandatory in requirements documents per JCIDS Manual: Force Protection KPP, System Survivability KPP, Sustainment KPP, Net-Ready KPP, Training KPP and Energy KPP.

The following KSAs are mandatory in AF requirements documents: the Flight Simulator KSA

Note 2: All processes feed the Gatekeeper Activities

Go Up 1 Level

Acquisition Process Model

1.3.2.1.4.2 Conduct Requirements Strategy Review (RSR-ICD)

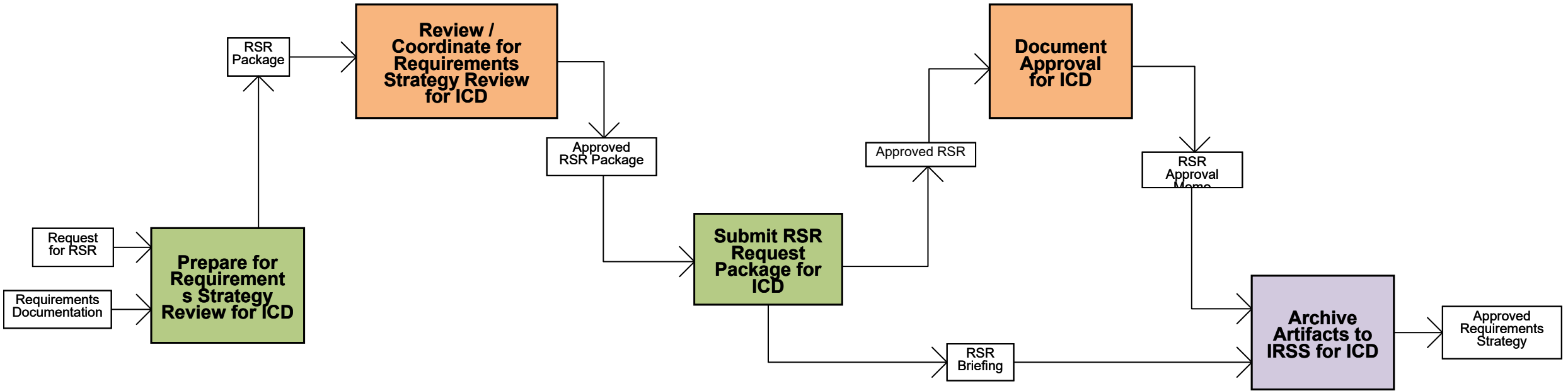

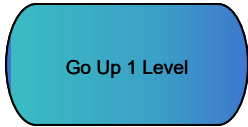

Acquisition Process Model

1.3.2.10 Conduct Program Assignment

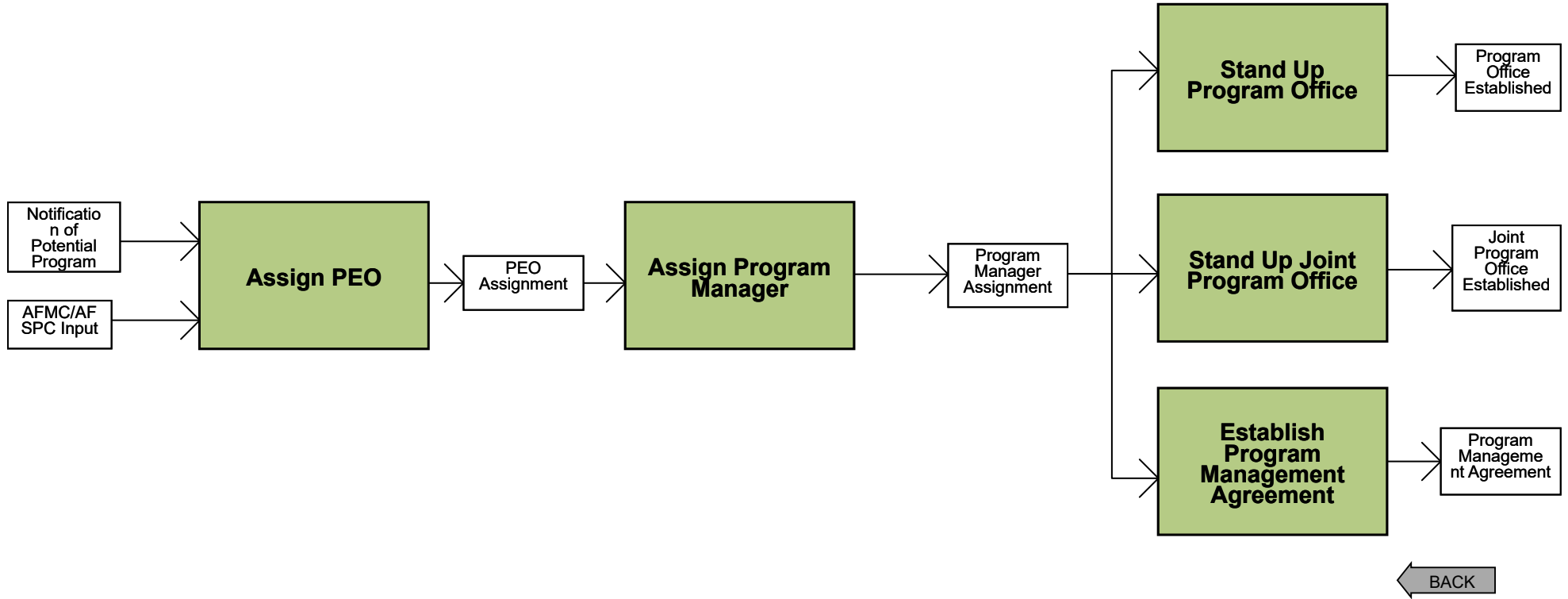



Acquisition Process Model

1.3.2.11 Conduct Source of Repair Assignment

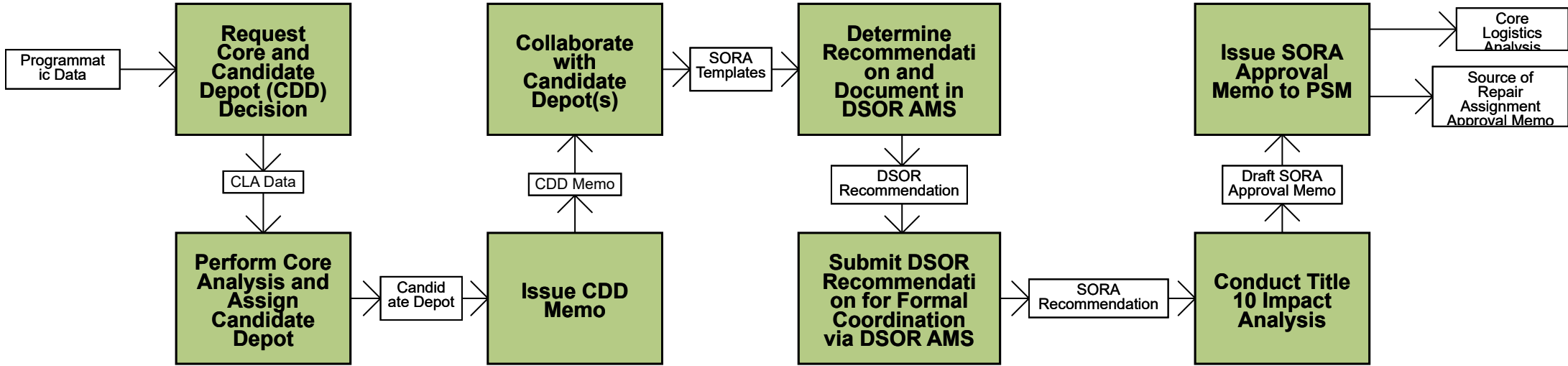

Go Up 1 Level

Acquisition Process Model

1.3.2.2 Generate Materiel Concepts

AFLCMC Standard Processes

PEO View

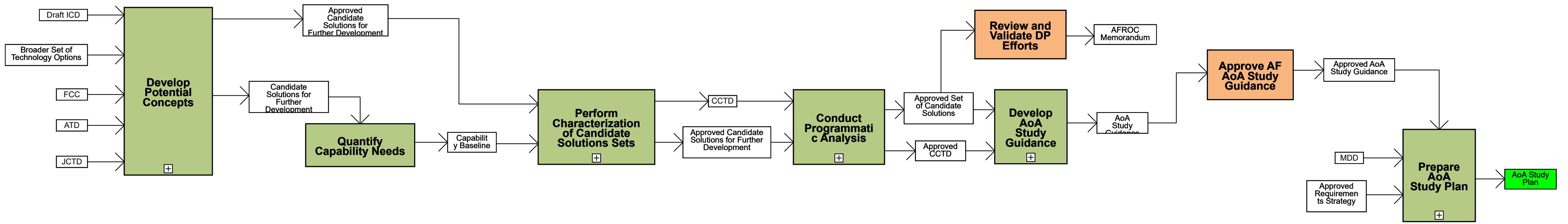

Note: The AFLCMC specific process for Development Planning intersects the Prepare AoA Study Plan. Click here to access an active link to the AFLCMC process.

BACK FWD

Go Up 1 Level

Acquisition Process Model

1.3.2.2.1 Develop Potential Concepts

AFLCMC Standard Processes

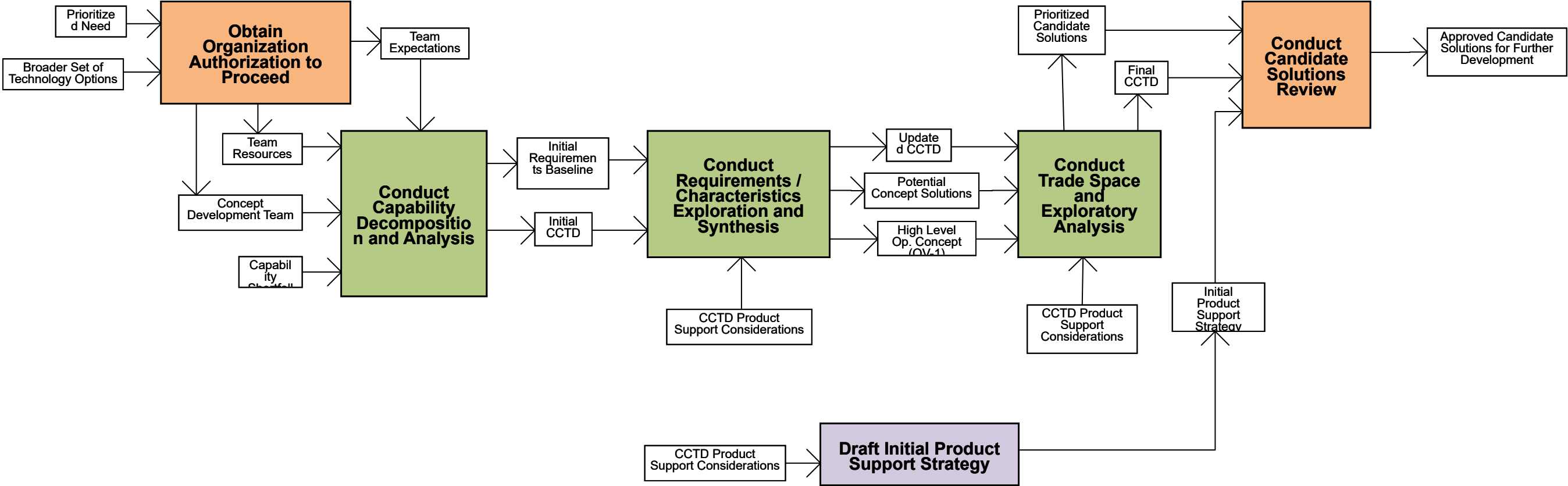

Note 1: At each approval step, one of three actions occurs: 1) Advance to the next step 2) Return to prior steps for rework 3) Archive the proposal due to immature technology

Note 2: The enabling processes are part of AFLCMC Standard Processes.

Note 3: Process 1.6 (Perform Concept Exploration and Refinement), of the AFLCMC Standard Processes is contained within the Core Processes.



FWD

Go Up 1 Level

Acquisition Process Model

1.3.2.2.3 Perform Candidate Solutions Sets Characterization

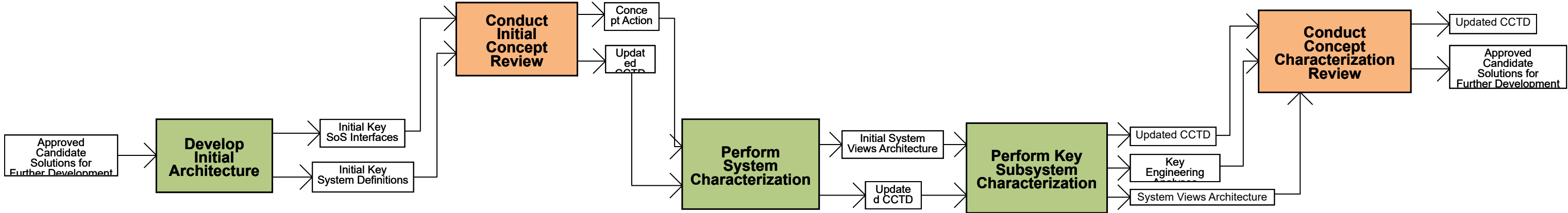

Note: At each approval step, one of three actions occurs: 1) Advance to the next step 2) Return to prior steps for rework 3) Archive the proposal due to immature technology

BACK FWD



Acquisition Process Model

1.3.2.2.4 Conduct Programmatic Analysis

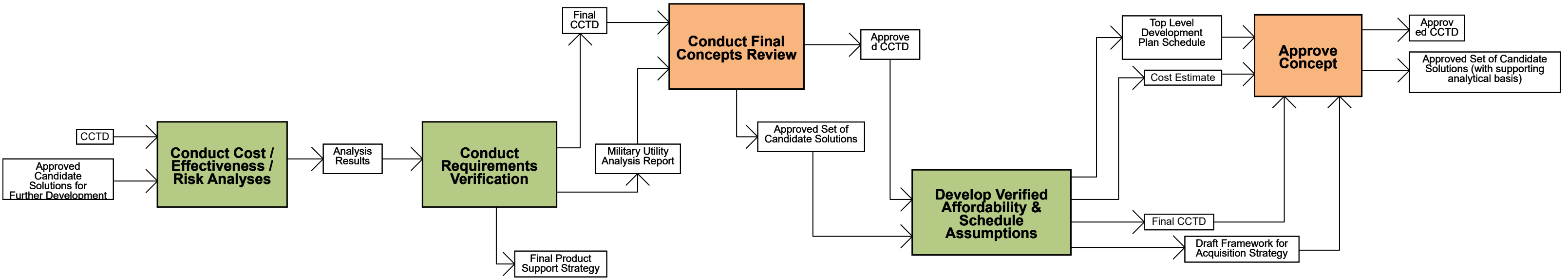

Note: At each approval step, one of three actions occurs: 1) Advance to the next step 2) Return to prior steps for rework 3) Archive the proposal due to immature technology

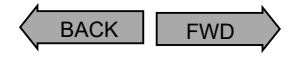

Go Up 1 Level

Acquisition Process Model

1.3.2.2.6 Develop AoA Study Guidance

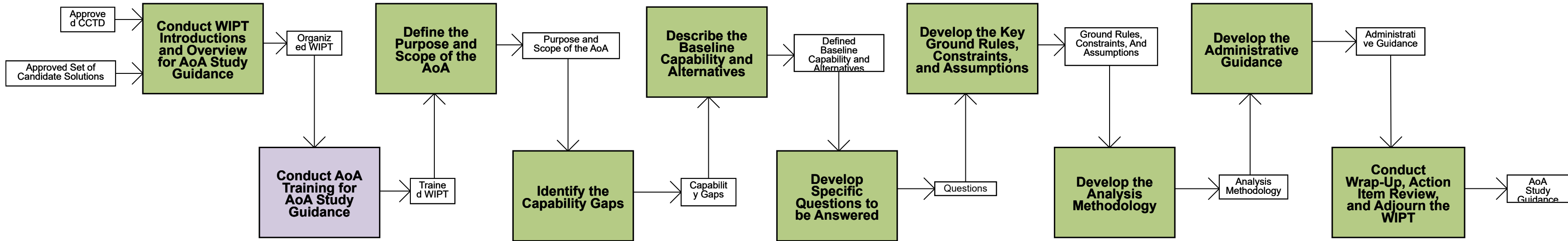

BACK FWD

Go Up 1 Level

Acquisition Process Model

1.3.2.2.8 Prepare AoA Study Plan

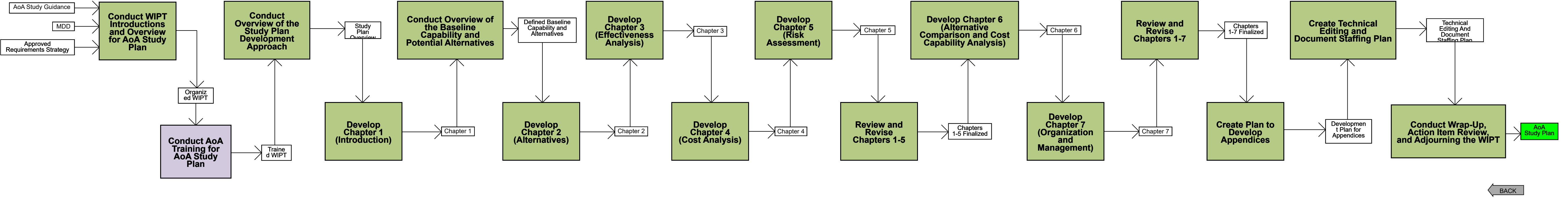

BACK

Go Up 1 Level

Acquisition Process Model

1.3.2.3 Conduct Materiel Solution Analysis

PEO View

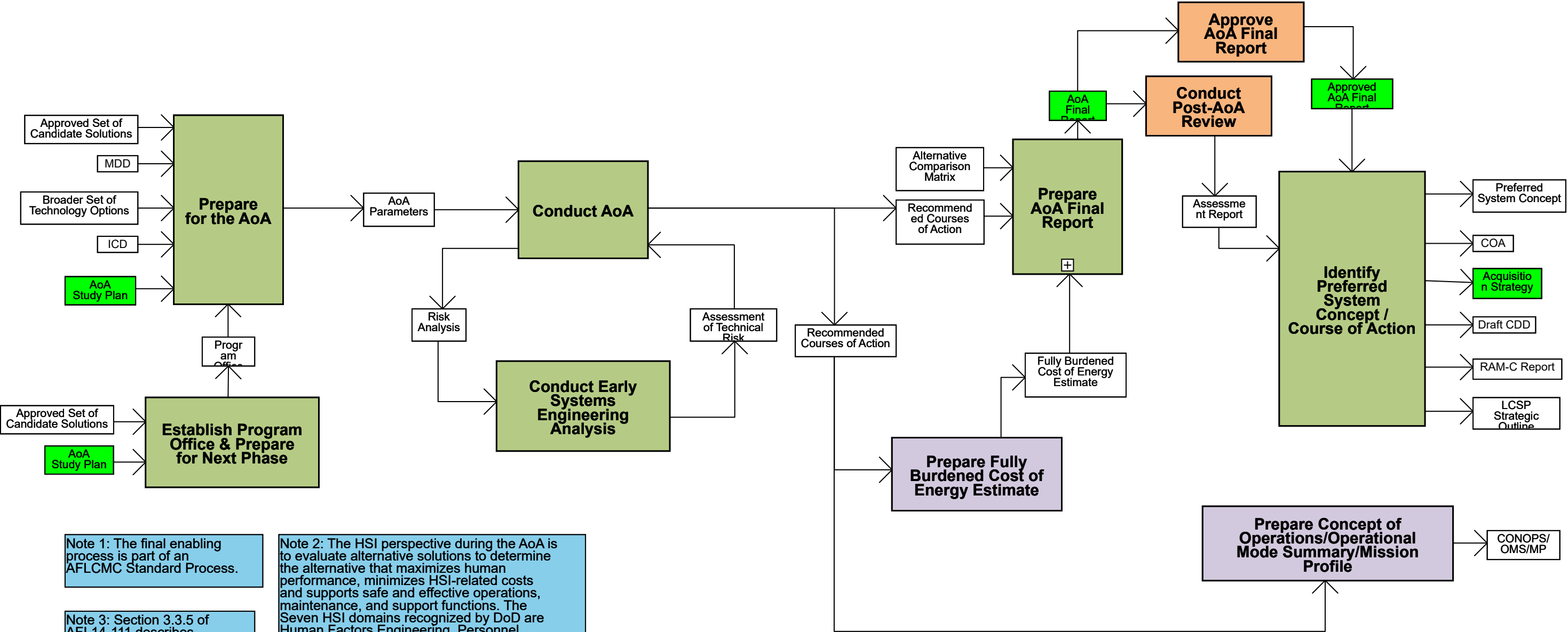

Note 1: The final enabling process is part of an AFLCMC Standard Process.

Note 2: The HSI perspective during the AoA is to evaluate alternative solutions to determine the alternative that maximizes human performance, minimizes HSI-related costs and supports safe and effective operations, maintenance, and support functions. The Seven HSI domains recognized by DoD are Human Factors Engineering, Personnel, Habitability, Manpower, Training, Safety and Occupational Health, and Force Protection and Survivability.

Note 3: Section 3.3.5 of AFI 14-111 describes various Working Groups that can support intelligence inputs to an AOA. Click here to access an active link to the AFI.

BACK FWD

Go Up 1 Level

Acquisition Process Model

1.3.2.3.7 Prepare AoA Final Report

PEO View

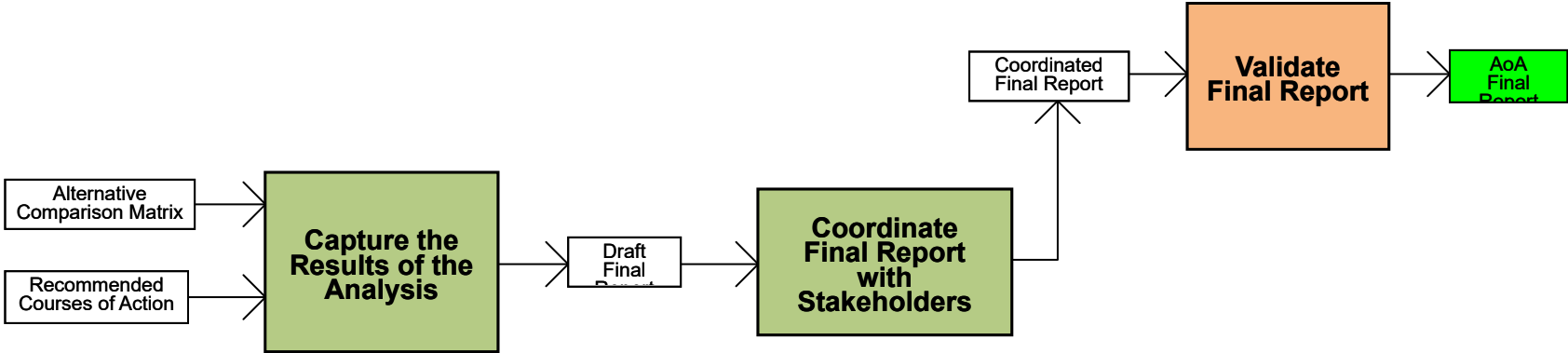

Go Up 1 Level

Acquisition Process Model

1.3.2.4 Refine Preferred System Concept

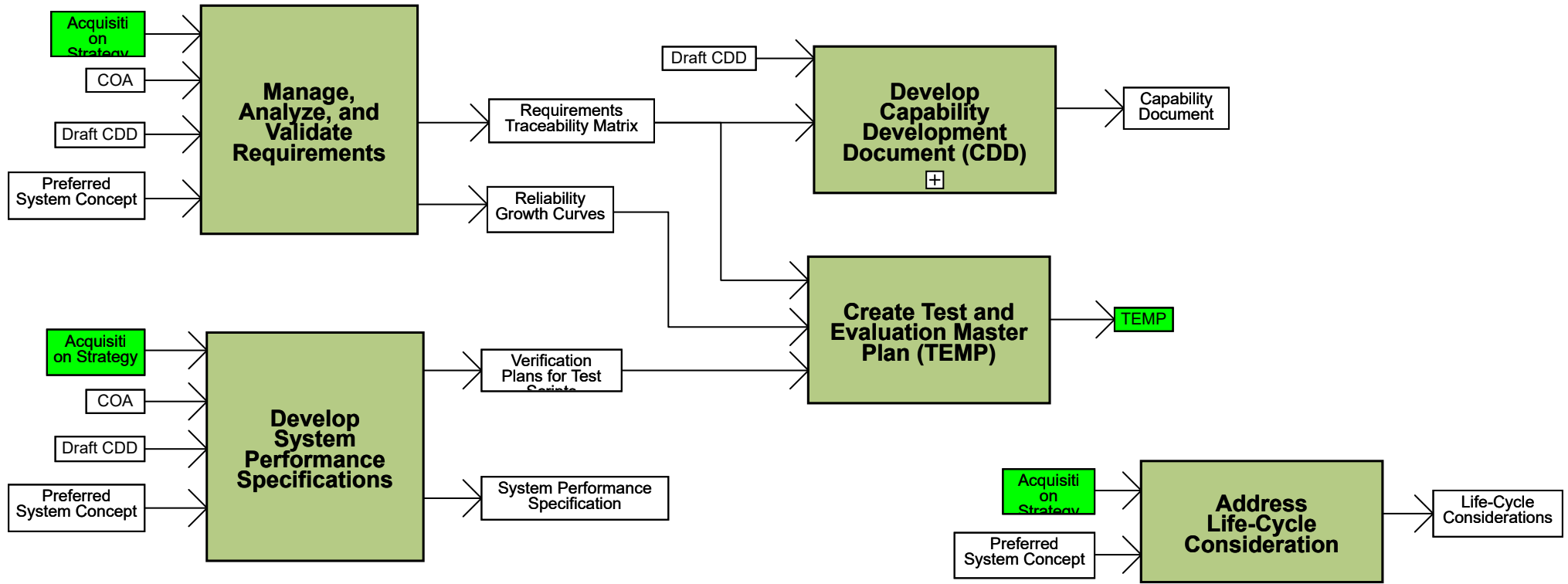

← BACK FWD →

Go Up 1 Level

Acquisition Process Model

1.3.2.4.2 Develop Capability Development Document (CDD)

PEO View

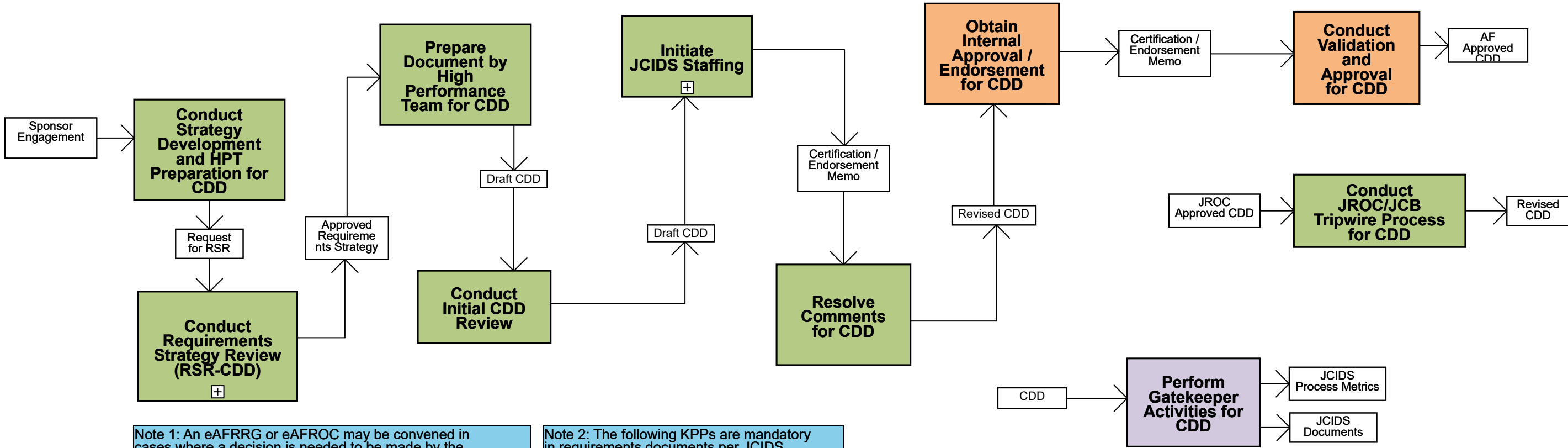

Note 1: An eAFRRG or eAFROC may be convened in cases where a decision is needed to be made by the AFRRG or AFROC body outside of the regularly scheduled AFRRG/AFROC cycle or in cases where the regular agenda is full and cannot wait until the next scheduled requirements review. eAFRRG and eAFROC will normally provide the principals five working days to review the materials. Principals are required to respond to eAFRRG/eAFROC in accordance with the AFRRG/AFROC Charter.

Note 2: The following KPPs are mandatory in requirements documents per JCIDS Manual: Force Protection KPP, System Survivability KPP, Sustainment KPP, Net-Ready KPP, Training KPP and Energy KPP. The following KSAs are mandatory in AF requirements documents: the Flight Simulator KSA.

Go Up 1 Level

Acquisition Process Model

1.3.2.4.2.2 Conduct Requirements Strategy Review (RSR - CDD)

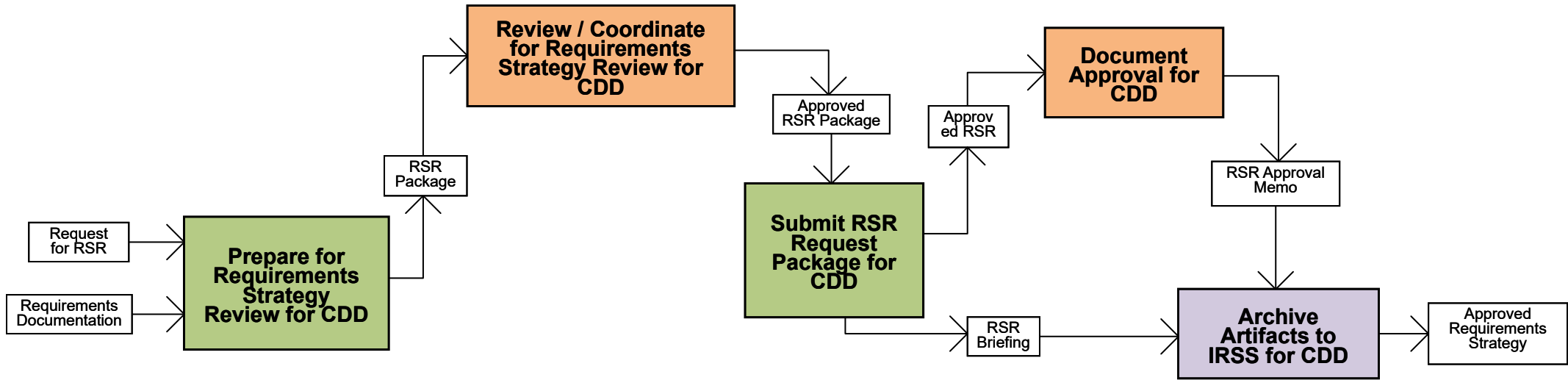

Go Up 1 Level

Acquisition Process Model

1.3.2.5 Develop Acquisition Strategy

AFLCMC Standard Processes

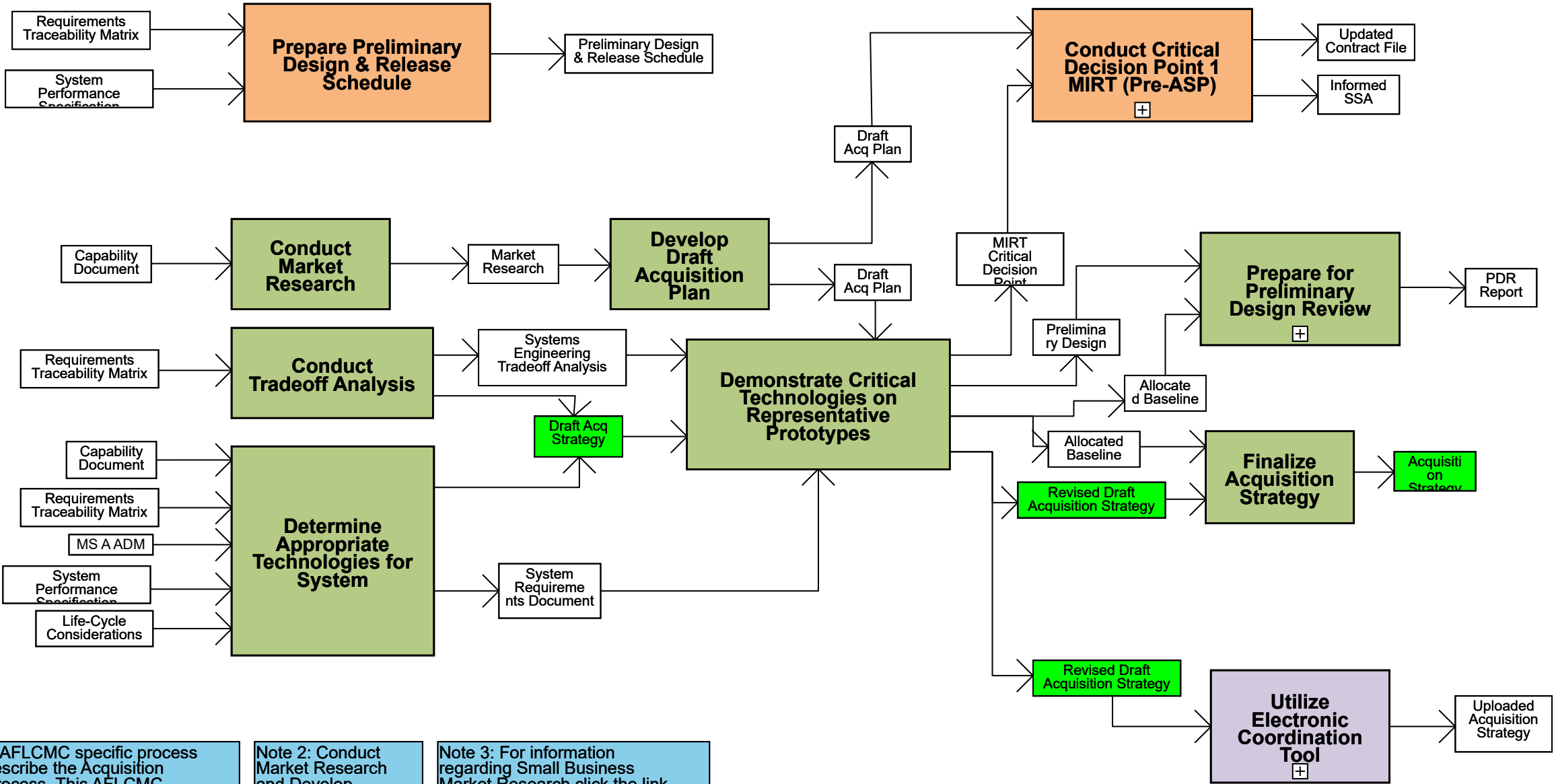

Note 1: An AFLCMC specific process exists to describe the Acquisition Strategy Process. This AFLCMC process is contained within the Air Force Process depicted here. Click here to access an active link to this process.

Note 2: Conduct Market Research and Develop Draft Acquisition Plan are predecessors to the 1.4.4.1 processes.

Note 3: For information regarding Small Business Market Research click the link below: SB. 1.1 Provide Market Research

Go Up 1 Level

Acquisition Process Model

1.3.2.5.4 Preliminary Design Review (PDR)

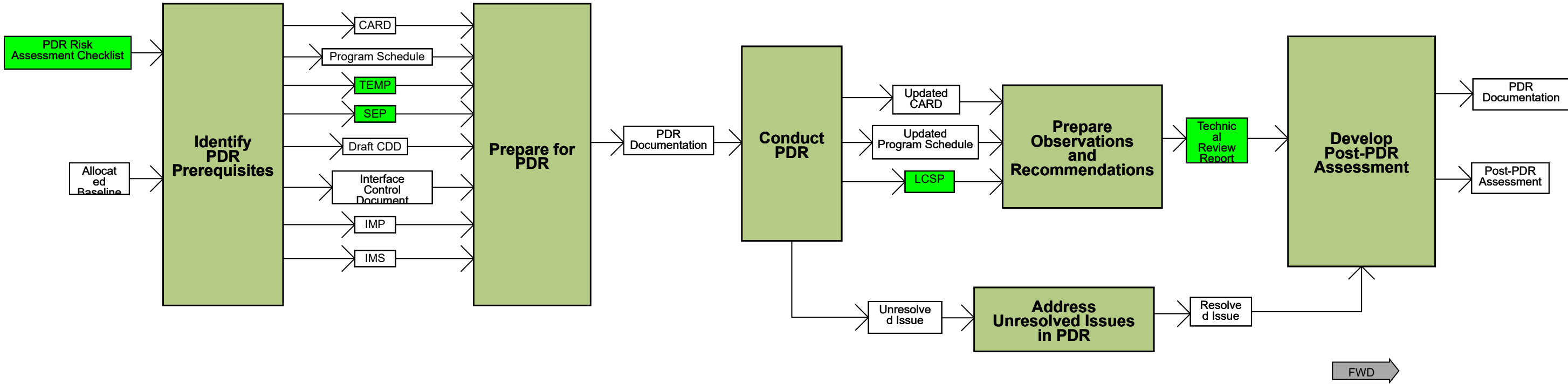

Go Up 1 Level

Acquisition Process Model

1.3.2.5.6 Conduct CDP 1 (Pre-ASP) MIRT

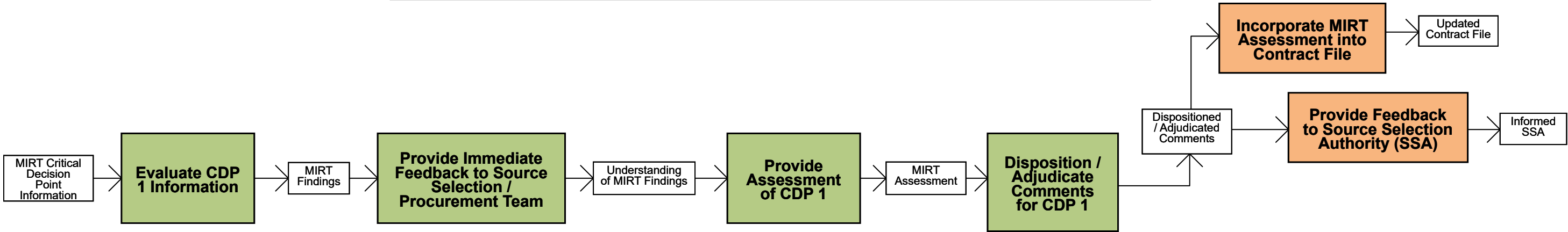

Note 1: For information regarding Small Business MIRT Click the link below:
[SB 1.6 Post Award/Stand Alone Processes](#)

BACK FWD

Go Up 1 Level

Acquisition Process Model

1.3.2.5.8 Utilize Electronic Coordination Tool

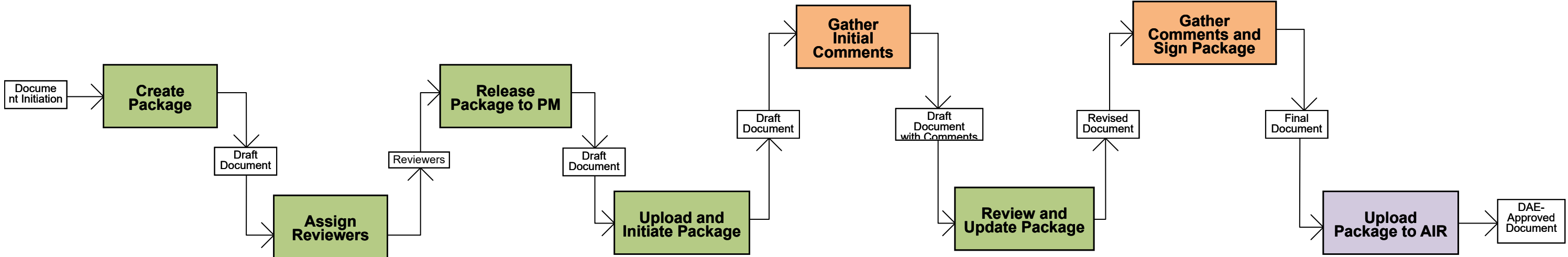

Note: Currently used for only the Acquisition Strategy, this process can apply to any milestone information requirement.

← BACK

Go Up 1 Level

Acquisition Process Model

1.3.2.6 Conduct Capability Gap Assessment

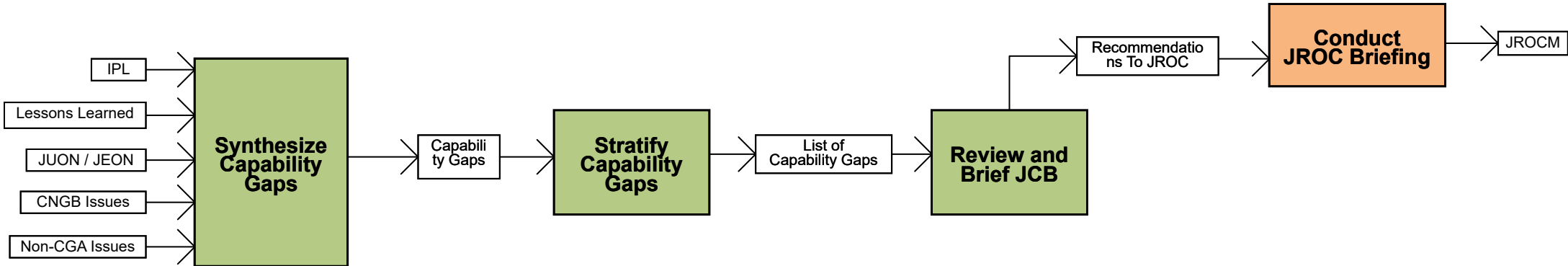

FWD

Go Up 1 Level

Acquisition Process Model

1.3.2.7 Conduct Cost Capability Analysis (CCA)

AFLCMC Standard Processes

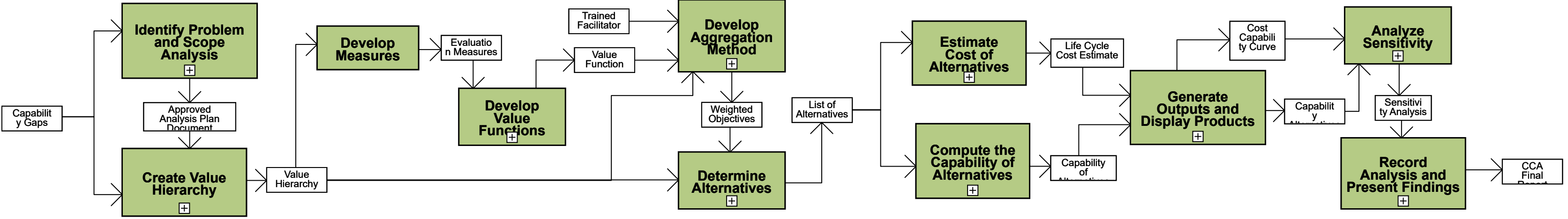

Note: This Process is repeated multiple times in the lifecycle of a program.

BACK FWD

Go Up 1 Level

Acquisition Process Model

1.3.2.7.1 Identify Problem and Scope Analysis

AFLCMC Standard Processes

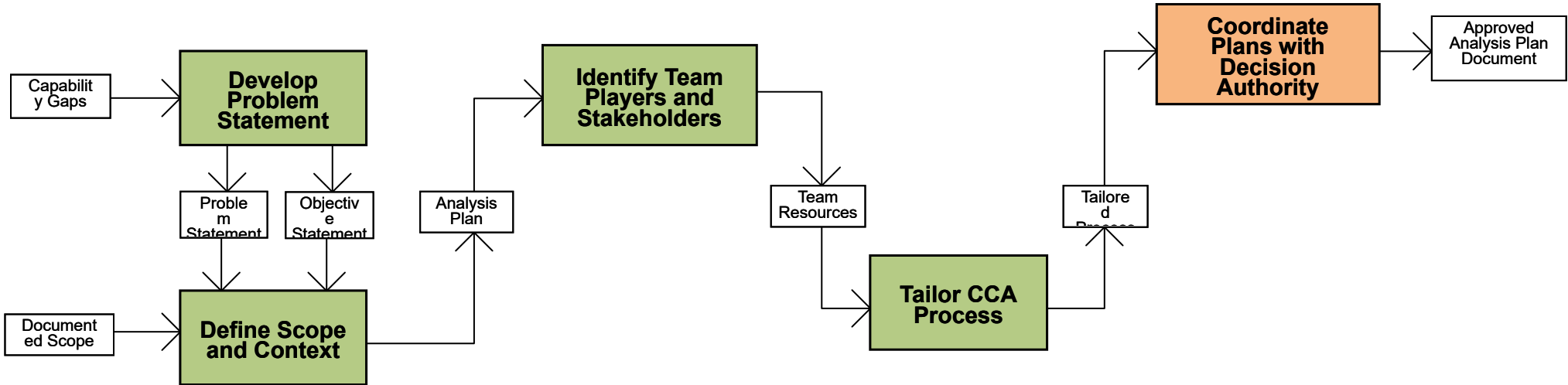

Note: This is an AFLCMC Standard Process

FWD

Go Up 1 Level

Acquisition Process Model

1.3.2.7.10 Analyze Sensitivity

AFLCMC
Standard
Processes

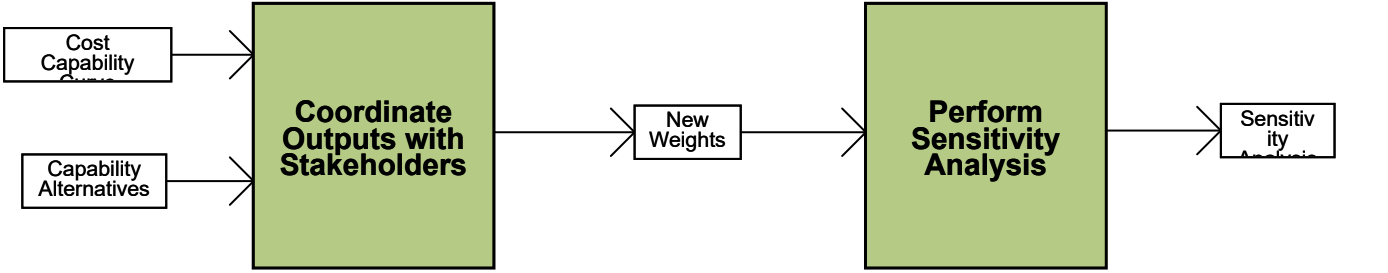

Note: This is an
AFLCMC Standard
Process

BACK FWD

Go Up 1 Level

Acquisition Process Model

1.3.2.7.11 Record Analysis and Present Findings

AFLCMC
Standard
Processes

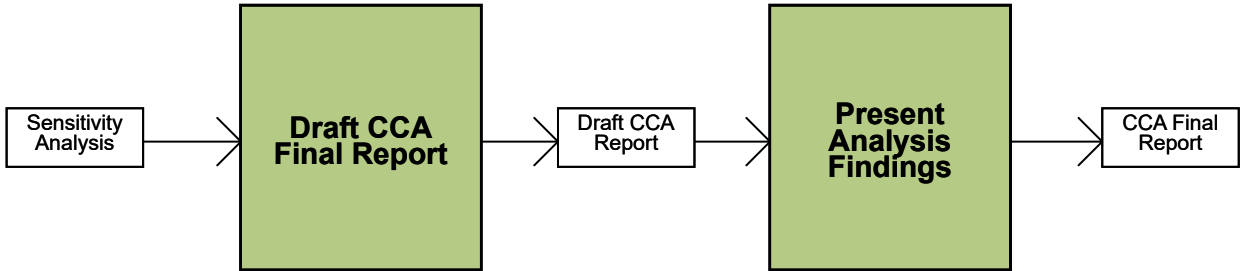

Note: This is an
AFLCMC Standard
Process

← BACK

Go Up 1 Level

Acquisition Process Model

1.3.2.7.2 Create Value Hierarchy

AFLCMC
Standard
Processes

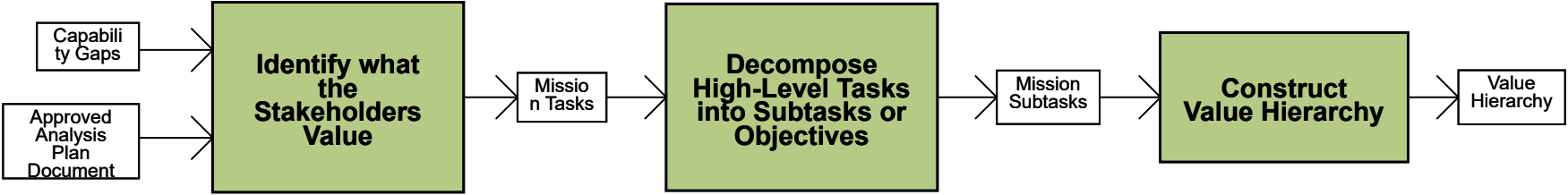

Note: This is an AFLCMC Standard Process

← BACK FWD →

Go Up 1 Level

Acquisition Process Model

1.3.2.7.4 Develop Value Function

AFLCMC
Standard
Processes

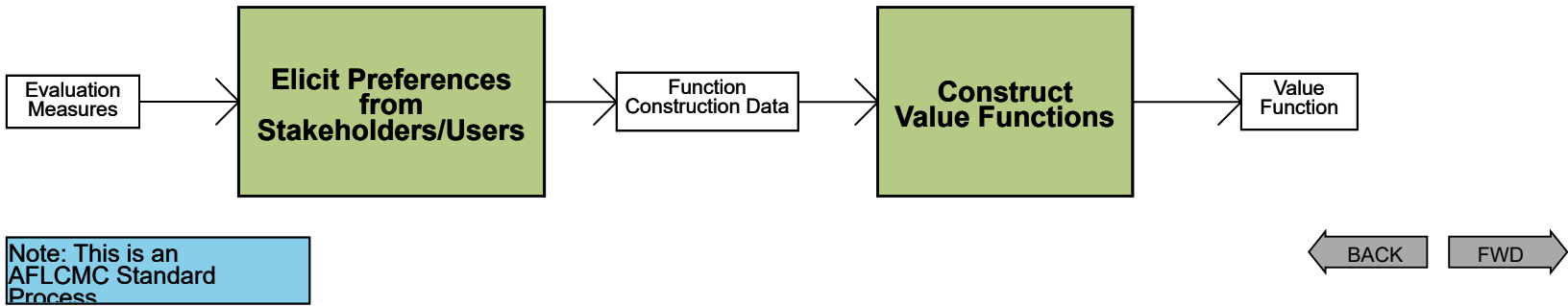

Go Up 1 Level

Acquisition Process Model

1.3.2.7.5 Develop Aggregation Method

AFLCMC
Standard
Processes

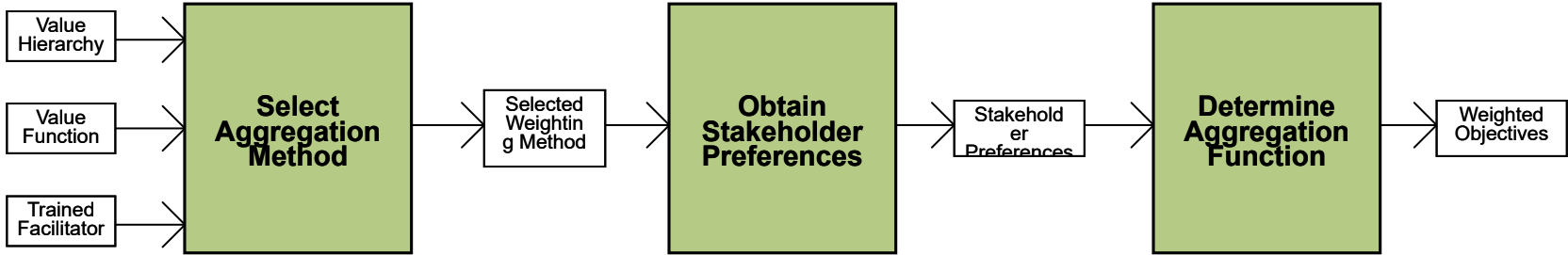

Note: This is an AFLCMC Standard Process

← BACK FWD →

Go Up 1 Level

Acquisition Process Model

1.3.2.7.6 Identify Alternatives

AFLCMC
Standard
Processes

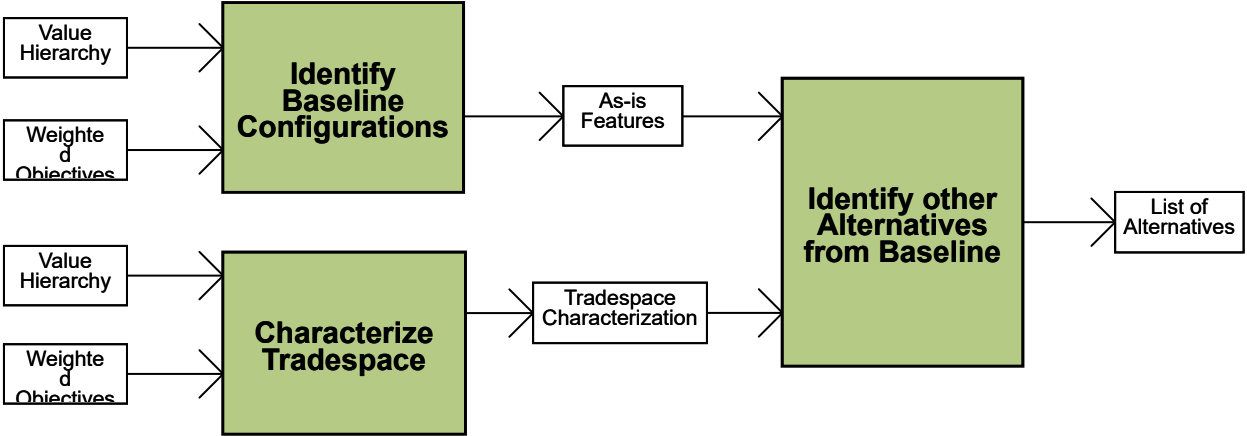

Note 1: This is an AFLCMC Standard Process

Note 2: This is an “or” process. You will either Identify Baseline Configuration or Characterize Tradespace.

← BACK FWD →

Go Up 1 Level

Acquisition Process Model

1.3.2.7.7 Compute the Capability of Alternatives

AFLCMC
Standard
Processes

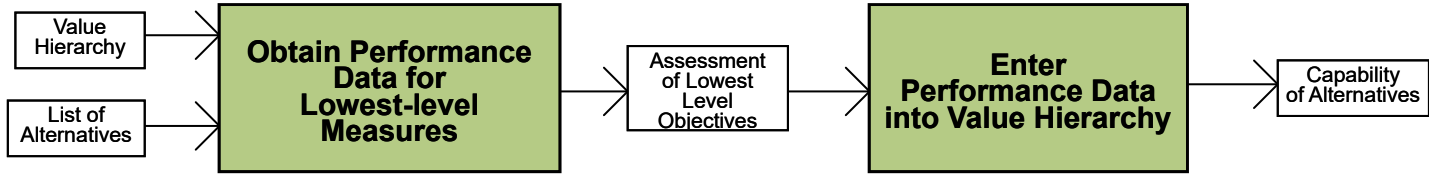

Note: This is an
AFLCMC Standard
Process

← BACK FWD →

Go Up 1 Level

Acquisition Process Model

1.3.2.7.8 Estimate the Cost of Each Alternatives

AFLCMC
Standard
Processes

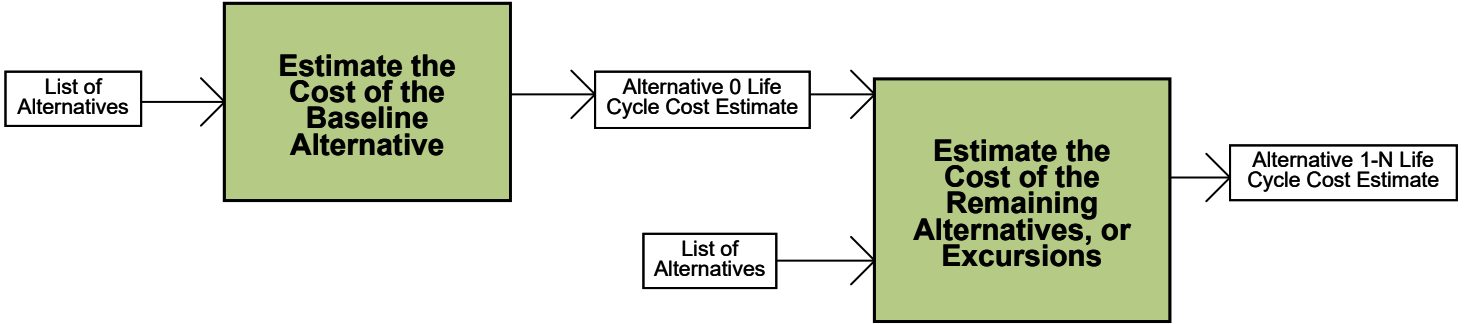

Note: This is an AFLCMC Standard Process

BACK FWD

Go Up 1 Level

Acquisition Process Model

1.3.2.7.9 Generate Outputs and Display Products

AFLCMC Standard Processes

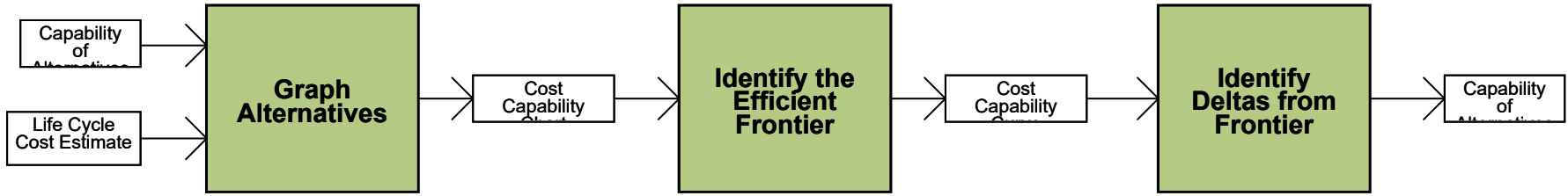

Note: This is an AFLCMC Standard Process

BACK FWD

Acquisition Process Model

1.3.2.8 Develop Life Cycle Sustainment Plan (LCSP)

Go Up 1 Level

AFLCMC
Standard
Processes

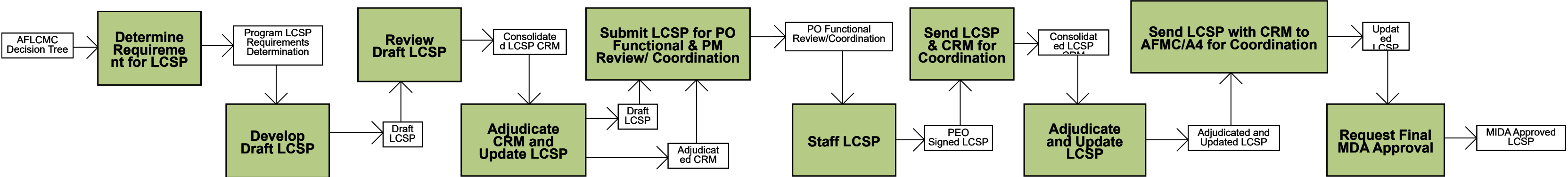

Note: This is an AFLCMC Standard Process

← BACK

Acquisition Process Model

1.3.2.9 Conduct Air Force Capability Development

Go Up 1 Level

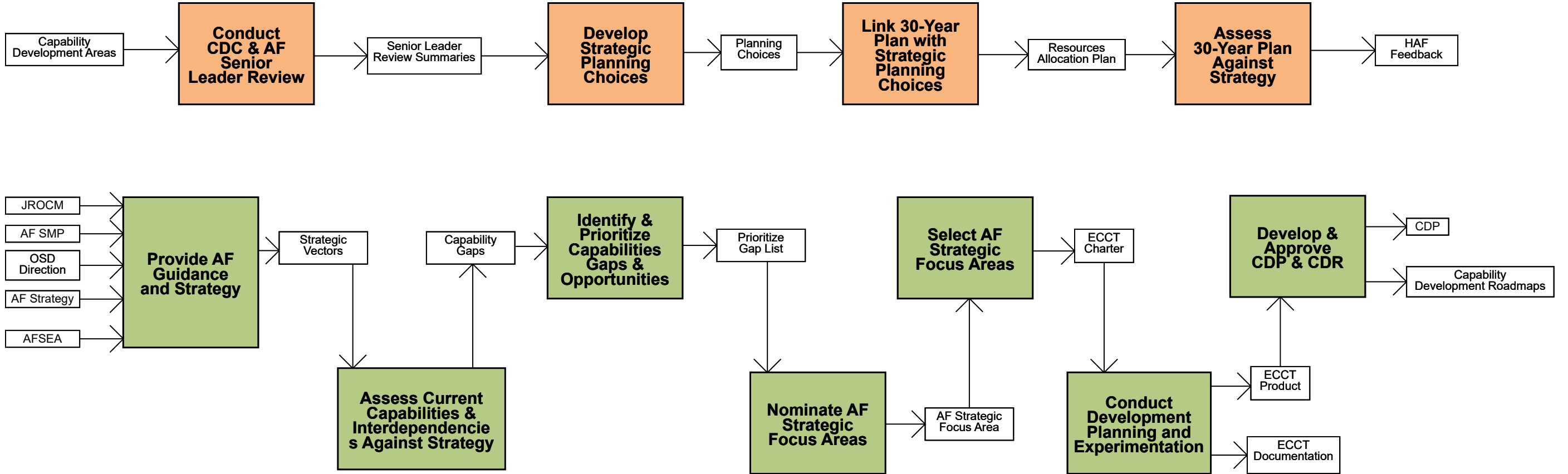

Note: The processes on this page reference a document that has expired with no new reference document in place to supersede it. However, the processes are still being conducted and until a new document is in place, the expired document can be used as a guide.

← BACK

FWD →

Acquisition Process Model

1.3.3 Address Accelerated Capability Needs

Go Up 1 Level

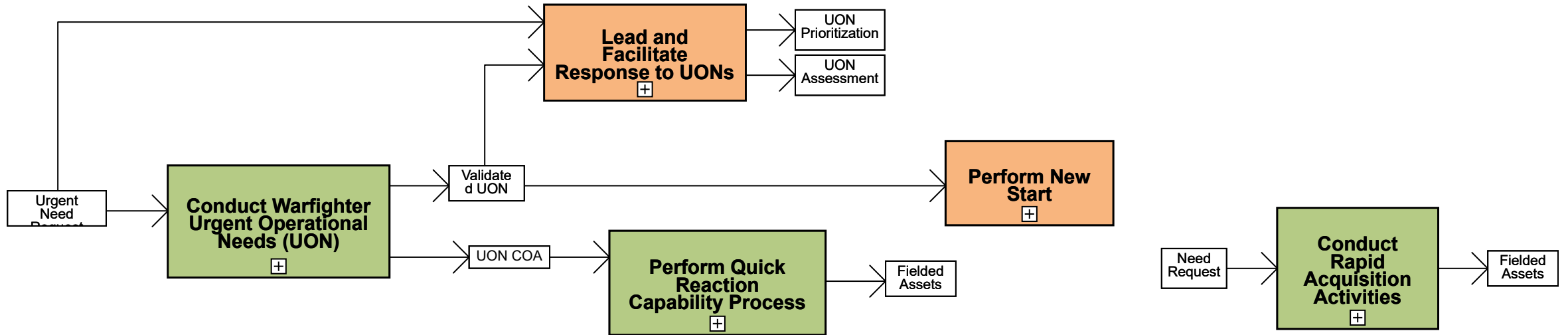

Note 1: The two core processes implement DoDI 5000.02, Enclosure 13 (Urgent Capability Acquisition).

Note 2: As described in CJCSI 3170.011 and the JCIDS Manual, "Emergent Operational Needs" are processed similarly to "Urgent Operational Needs."

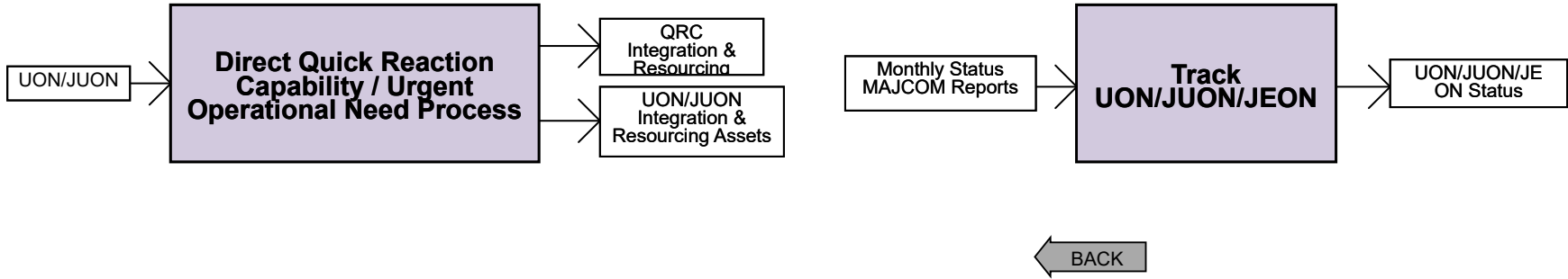

← BACK

Go Up 1 Level

Acquisition Process Model

1.3.3.1 Conduct Warfighter Urgent Operational Needs

PEO View

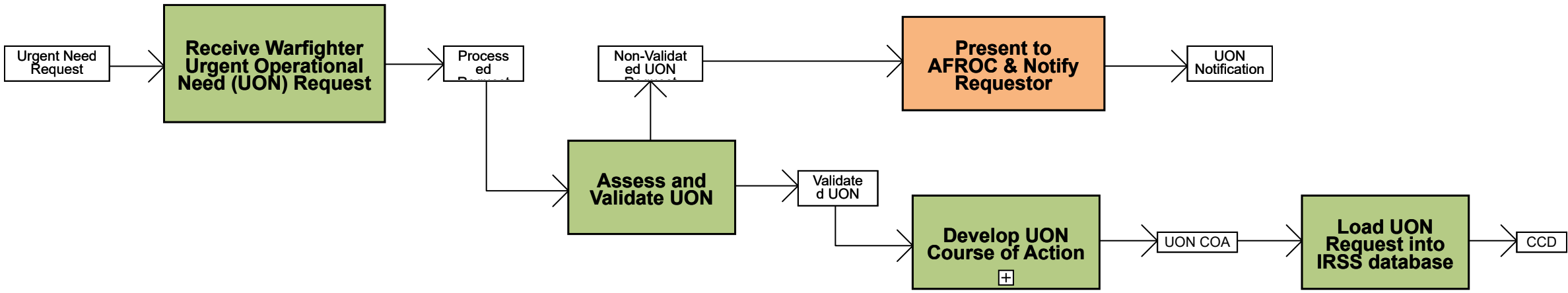

Note: As described in CJCSI 3170.011 and the JCIDS Manual, "Emergent Operational Needs" are processed similarly to "Urgent Operational Needs."

FWD

Go Up 1 Level

Acquisition Process Model

1.3.3.1.3 Develop Course of Action (COA)

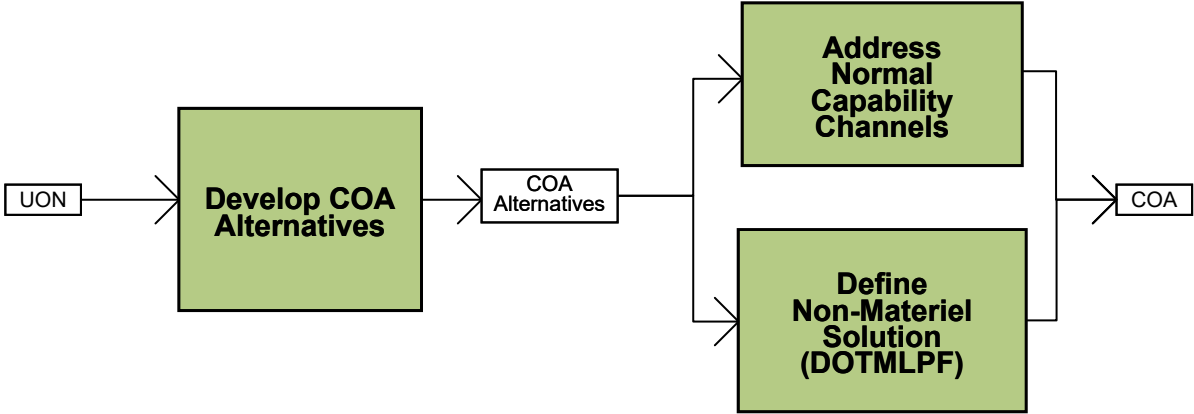

Go Up 1 Level

Acquisition Process Model

1.3.3.2 Perform Quick Reaction Capability (QRC) Process

PEO View

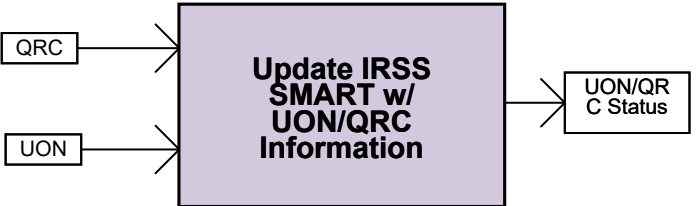
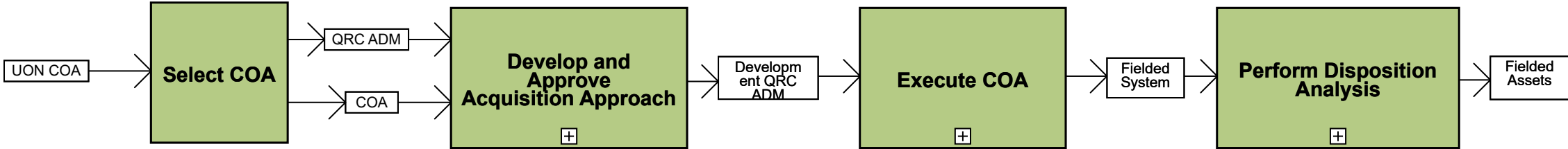

BACK FWD

Go Up 1 Level

Acquisition Process Model

1.3.3.2.2 Develop and Approve Acquisition Approach

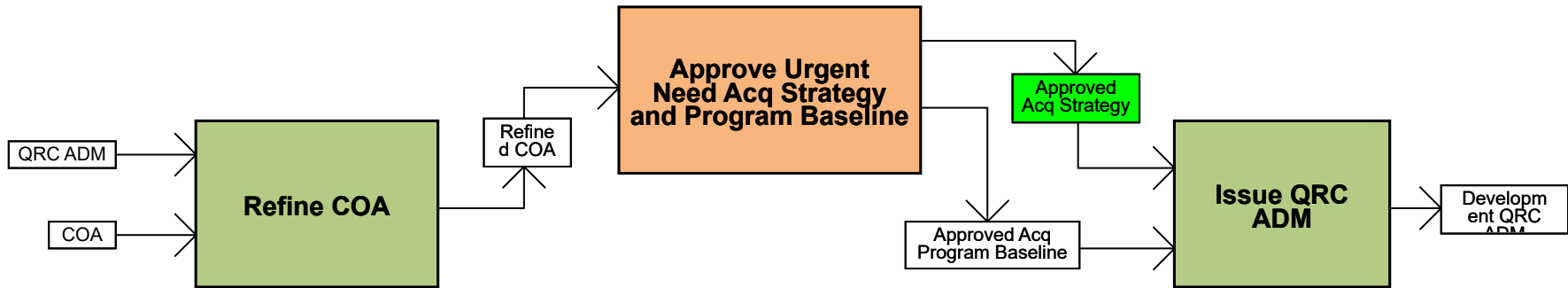

FWD

Go Up 1 Level

Acquisition Process Model

1.3.3.2.3 Execute COA

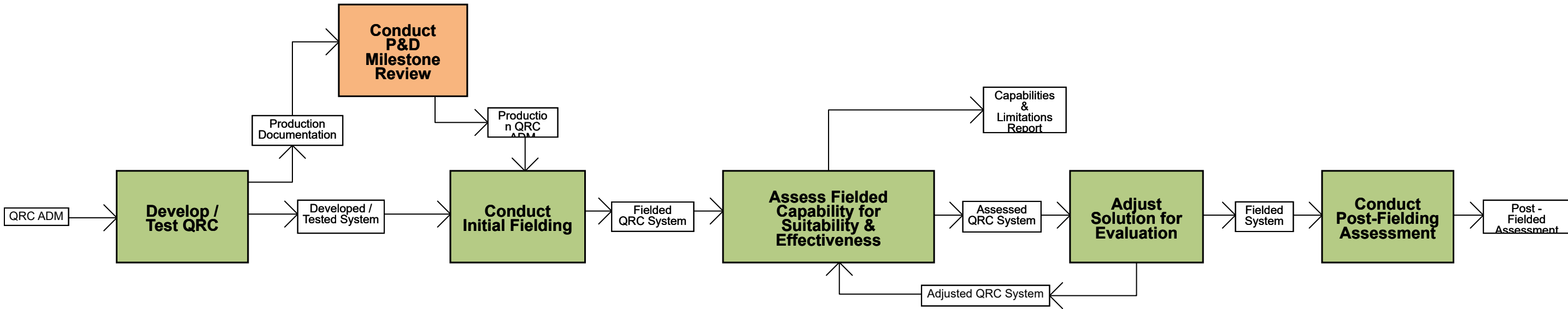

← BACK

FWD →

Go Up 1 Level

Acquisition Process Model

1.3.3.2.4 Perform Disposition Analysis

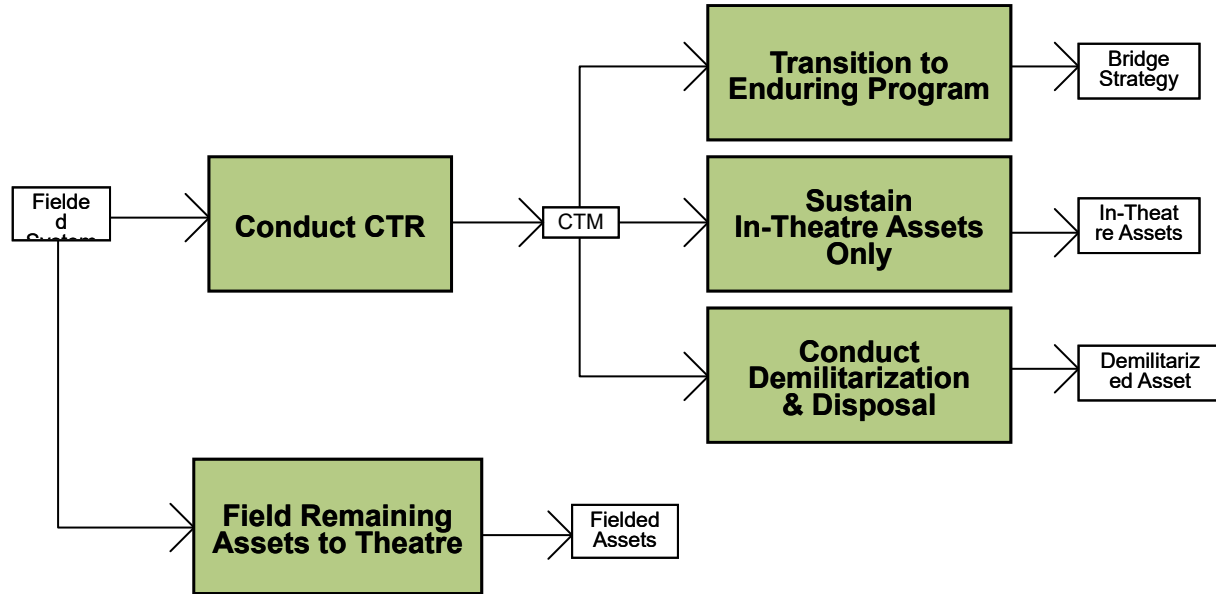

← BACK

Go Up 1 Level

Acquisition Process Model

1.3.3.3 Conduct New Start Notification Process

PEO View

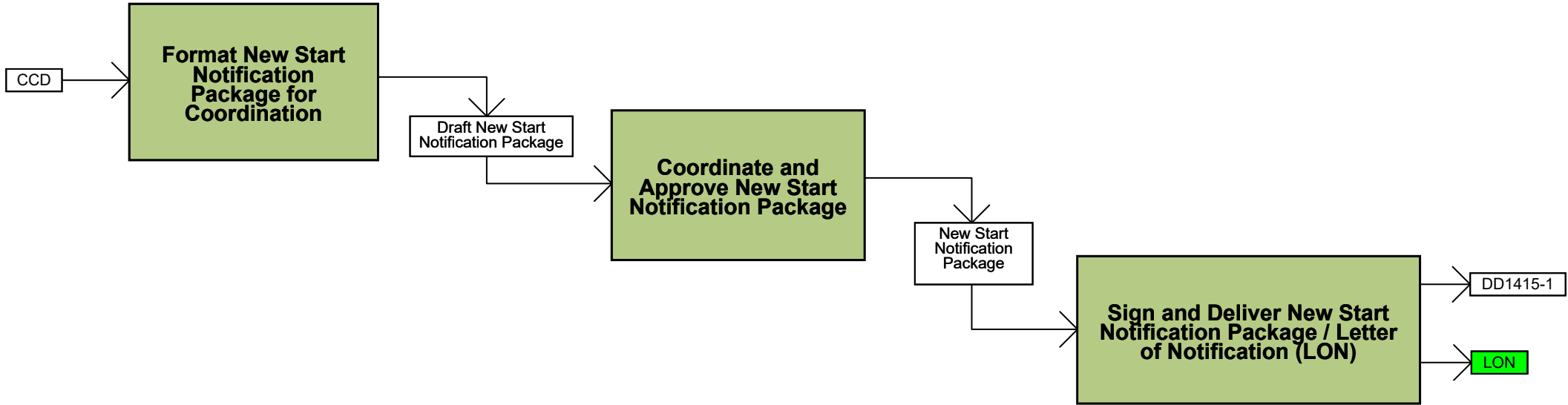

Note: PM Responsibilities outlined in AFI 63-101/20-101 Section 2.10

← BACK

FWD →

Go Up 1 Level

Acquisition Process Model

1.3.3.4 Conduct Rapid Acquisition Activities

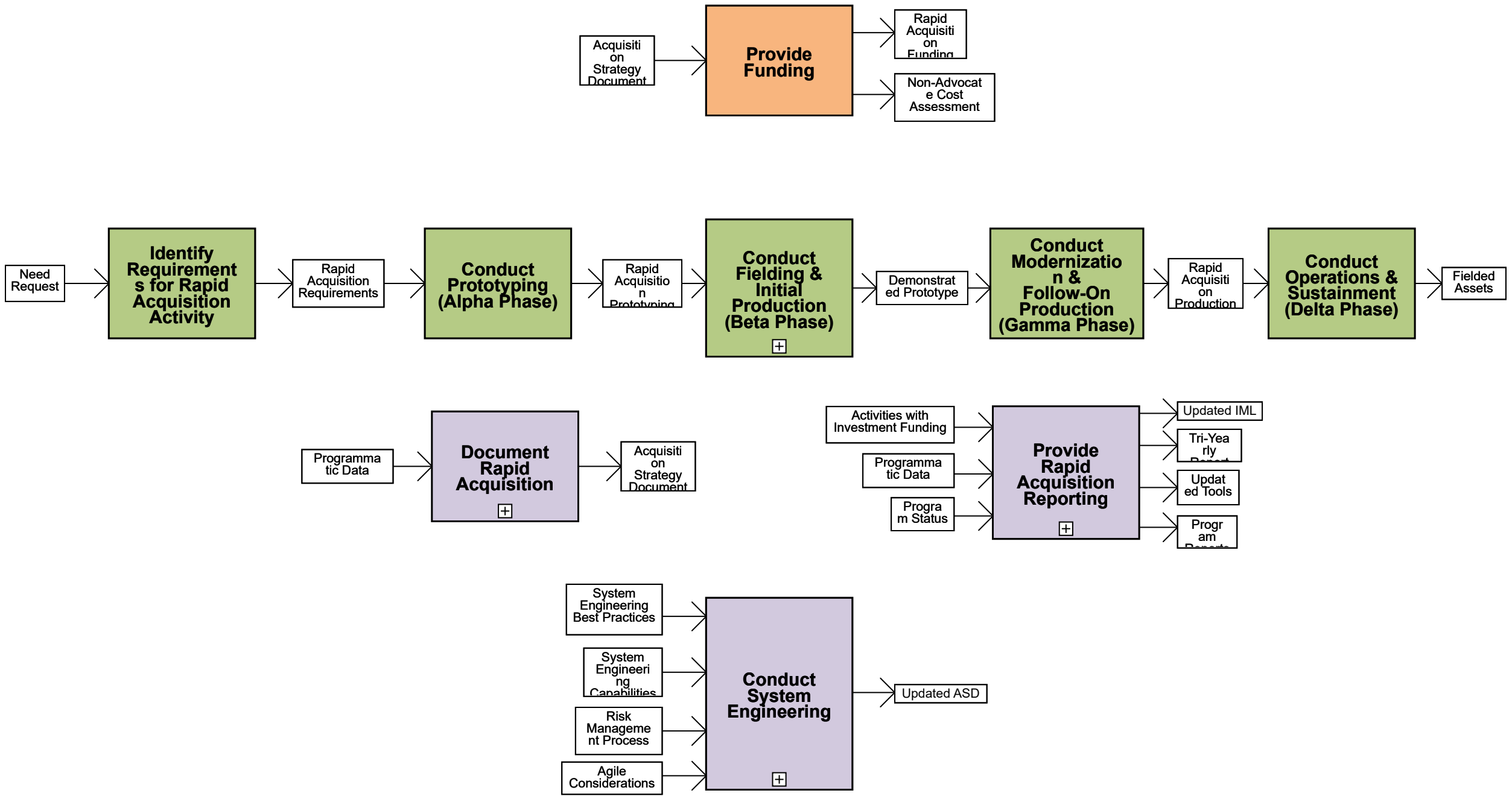

BACK

FWD

Go Up 1 Level

Acquisition Process Model

1.3.3.4.4 Conduct Fielding & Initial Production (Beta Phase)

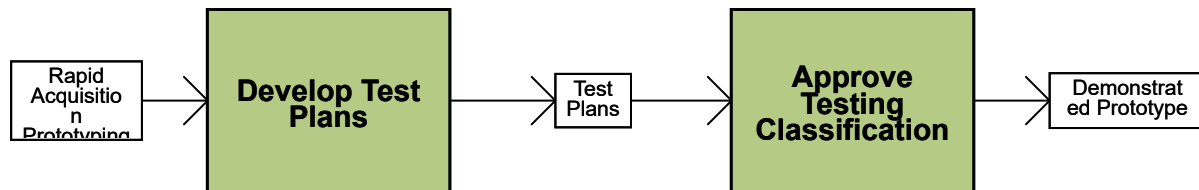

FWD

Go Up 1 Level

Acquisition Process Model

1.3.3.4.7 Document Rapid Acquisition

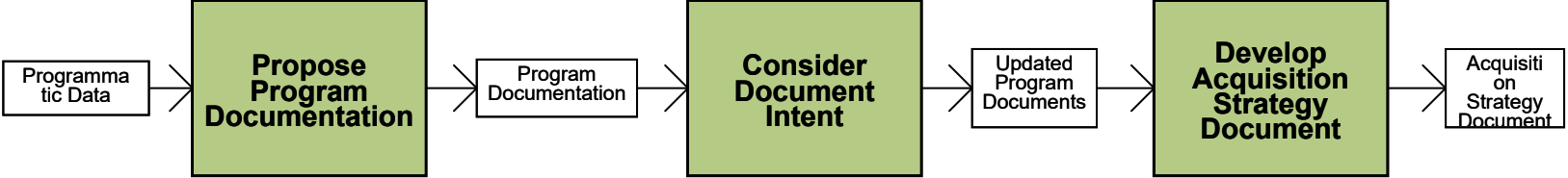

← BACK FWD →

Go Up 1 Level

Acquisition Process Model

1.3.3.4.8 Conduct System Engineering

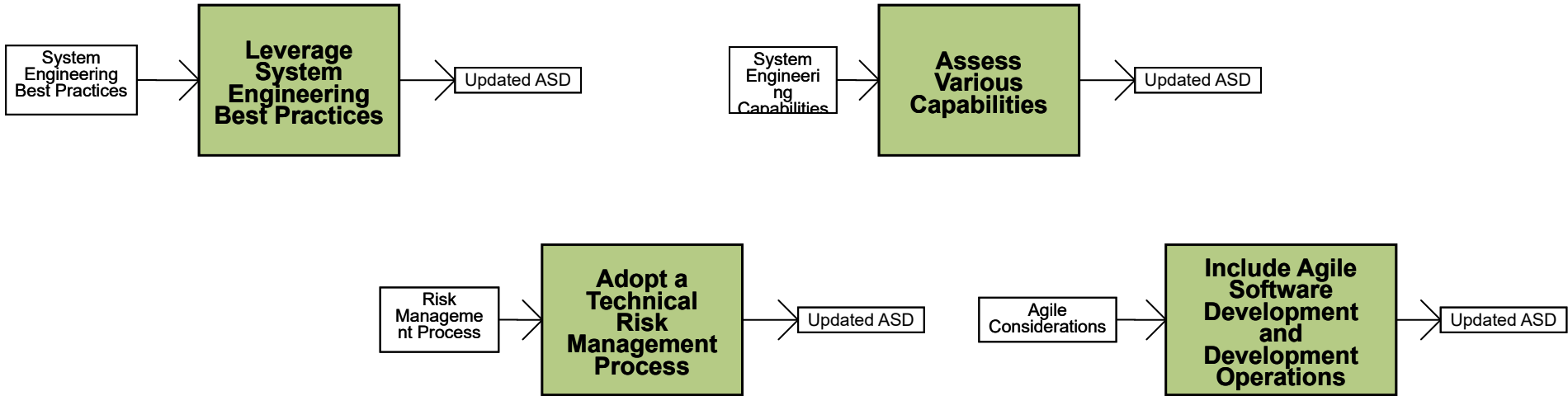

BACK FWD

Go Up 1 Level

Acquisition Process Model

1.3.3.4.9 Provide Rapid Acquisition Reporting

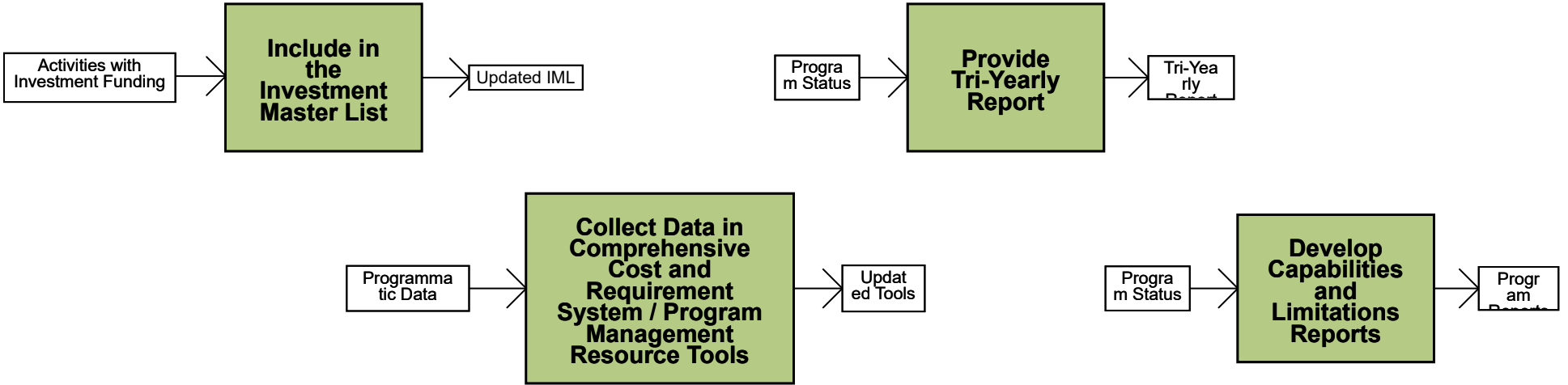

← BACK



Acquisition Process Model

1.3.3.6 Lead and Facilitate Response to UONs

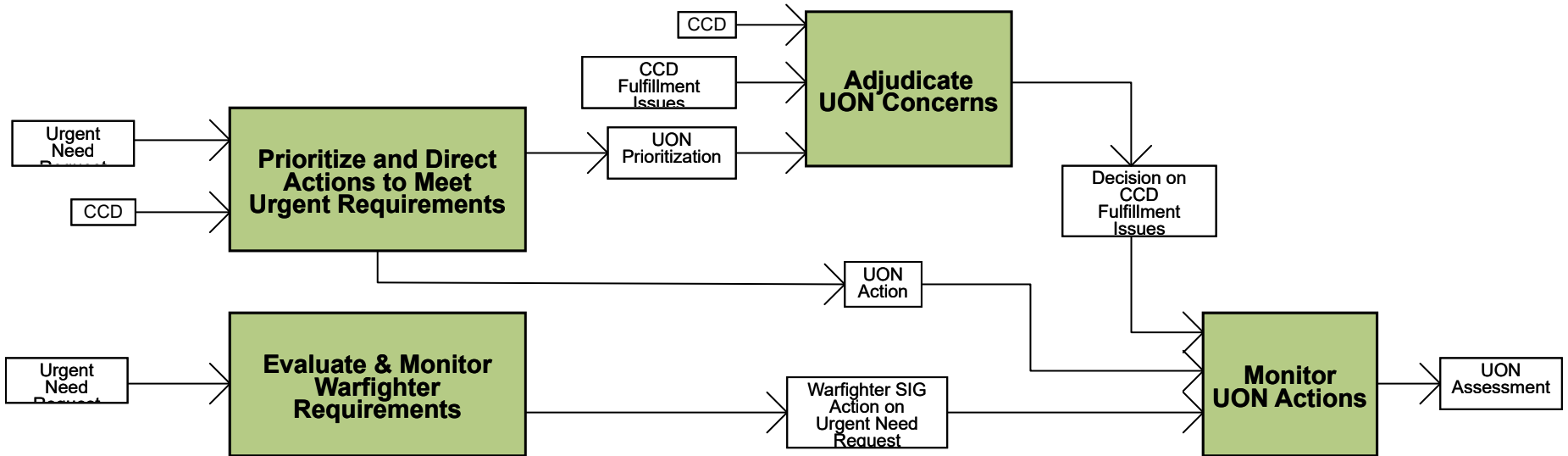

Note: The Warfighter SIG may establish DoD-level task forces, as required, to focus DoD efforts to resolve UONs or address capability surprises within specified capability domains.

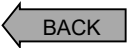

Go Up 1 Level

Acquisition Process Model

1.4 Acquire

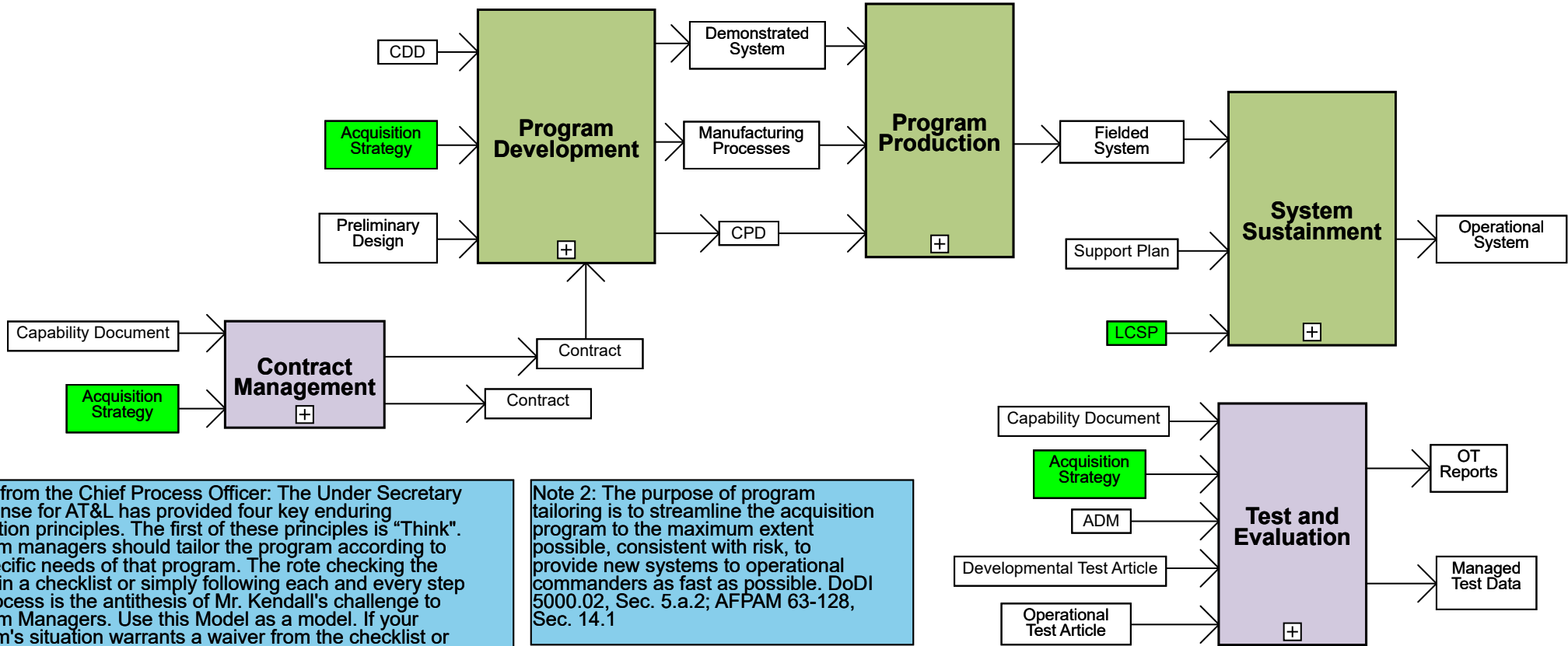

Note 1 from the Chief Process Officer: The Under Secretary of Defense for AT&L has provided four key enduring acquisition principles. The first of these principles is "Think". Program managers should tailor the program according to the specific needs of that program. The rote checking the blocks in a checklist or simply following each and every step of a process is the antithesis of Mr. Kendall's challenge to Program Managers. Use this Model as a model. If your program's situation warrants a waiver from the checklist or process, seek that waiver from your milestone decision authority. Click here to access an active link to Mr. Kendall's thoughts.

Note 2: The purpose of program tailoring is to streamline the acquisition program to the maximum extent possible, consistent with risk, to provide new systems to operational commanders as fast as possible. DoDI 5000.02, Sec. 5.a.2; AFPAM 63-128, Sec. 14.1

← BACK
FWD →

Go Up 1 Level

Acquisition Process Model

1.4.1 Program Development

PEO View

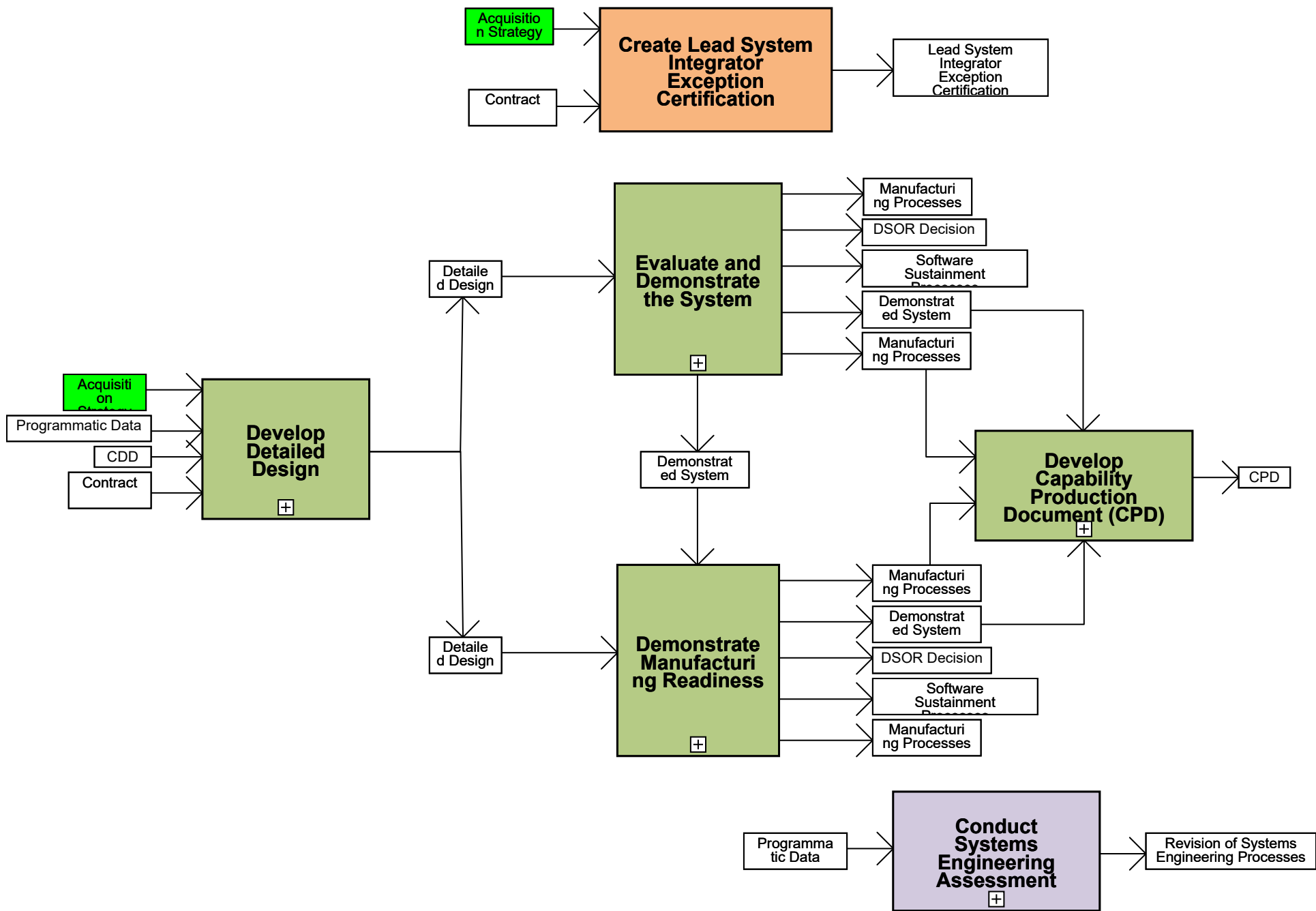

FWD

Note 1: The following websites provide valuable information for product support activities. The DoD Integrated Product Support Implementation Roadmap has links to over 2500 knowledge items (such as policy, references, and continuous learning modules). The Roadmap identifies activities and outputs for the twelve integrated product support (IPS) elements over the total life cycle. DoD has also established a Product Support Manager website that provides links to a variety of relevant documents. Finally, the Air Force has developed the Contract Sustainment Support Guide to provide best practices for contractor logistics support. Click here to access an active link to each of the above.

Note 2: This enabling process is based on the AFMC/EN and SMC/EN sponsored SEAM Guide.

Note 3: Enclosure 14, Sections 4 and 7 of DoDI 5000.02 provide a list of actions that RDT&E Organizations/Program Managers should take relative to Cybersecurity. Click here to access an active link to the instruction.

Go Up 1 Level

Acquisition Process Model

1.4.1.1 Develop Detailed Design

PEO View

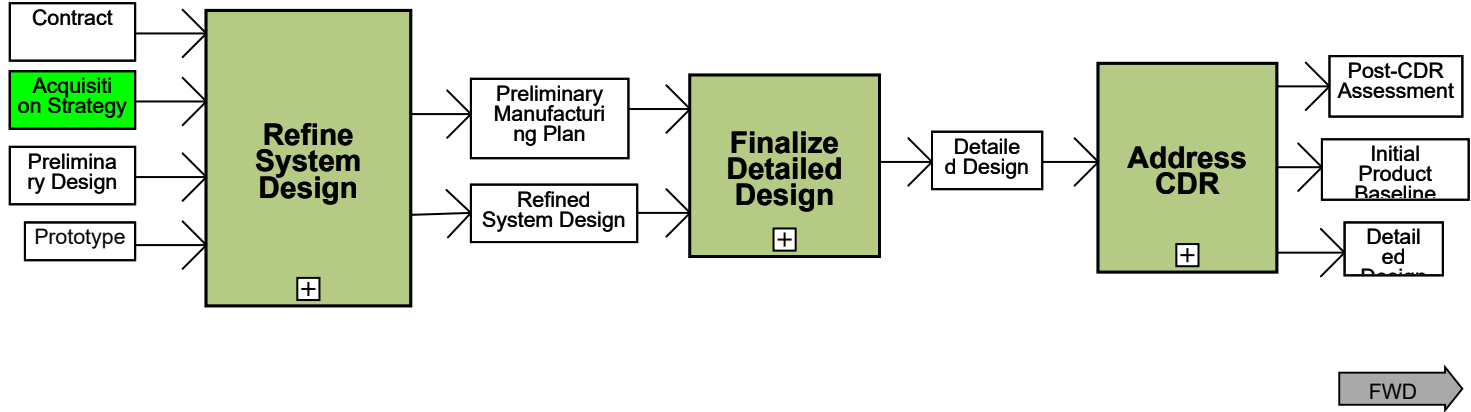

Go Up 1 Level

Acquisition Process Model

1.4.1.1 Refine System Design

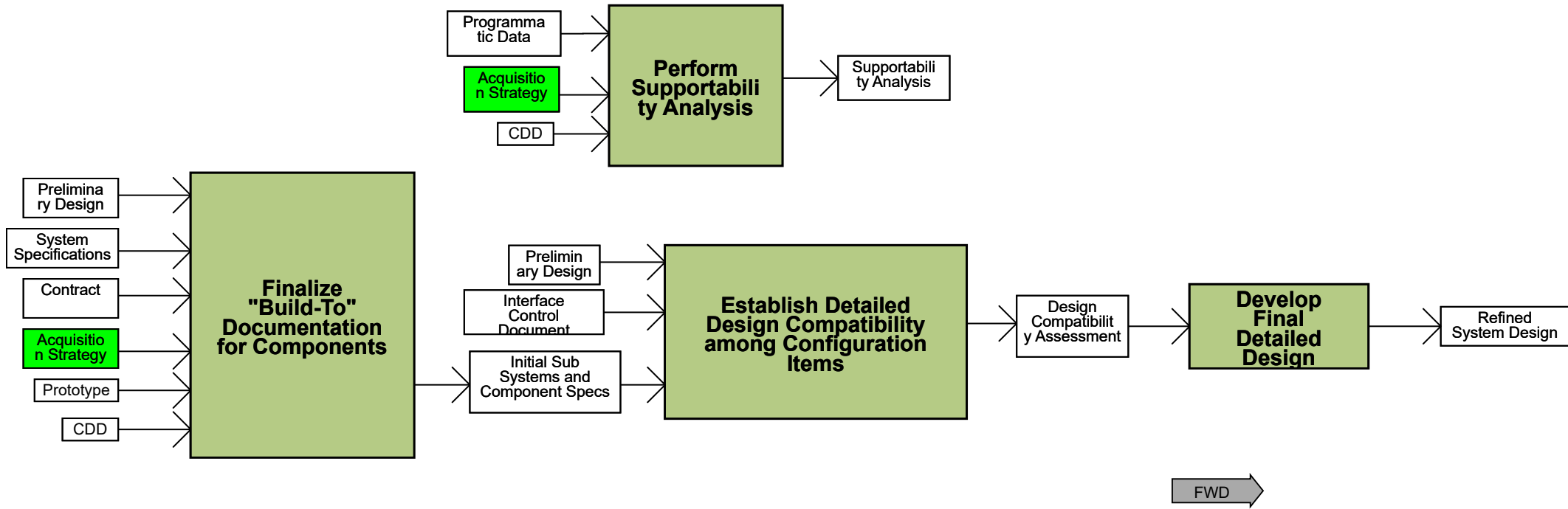

Go Up 1 Level

Acquisition Process Model

1.4.1.1.2 Finalize Detailed Design

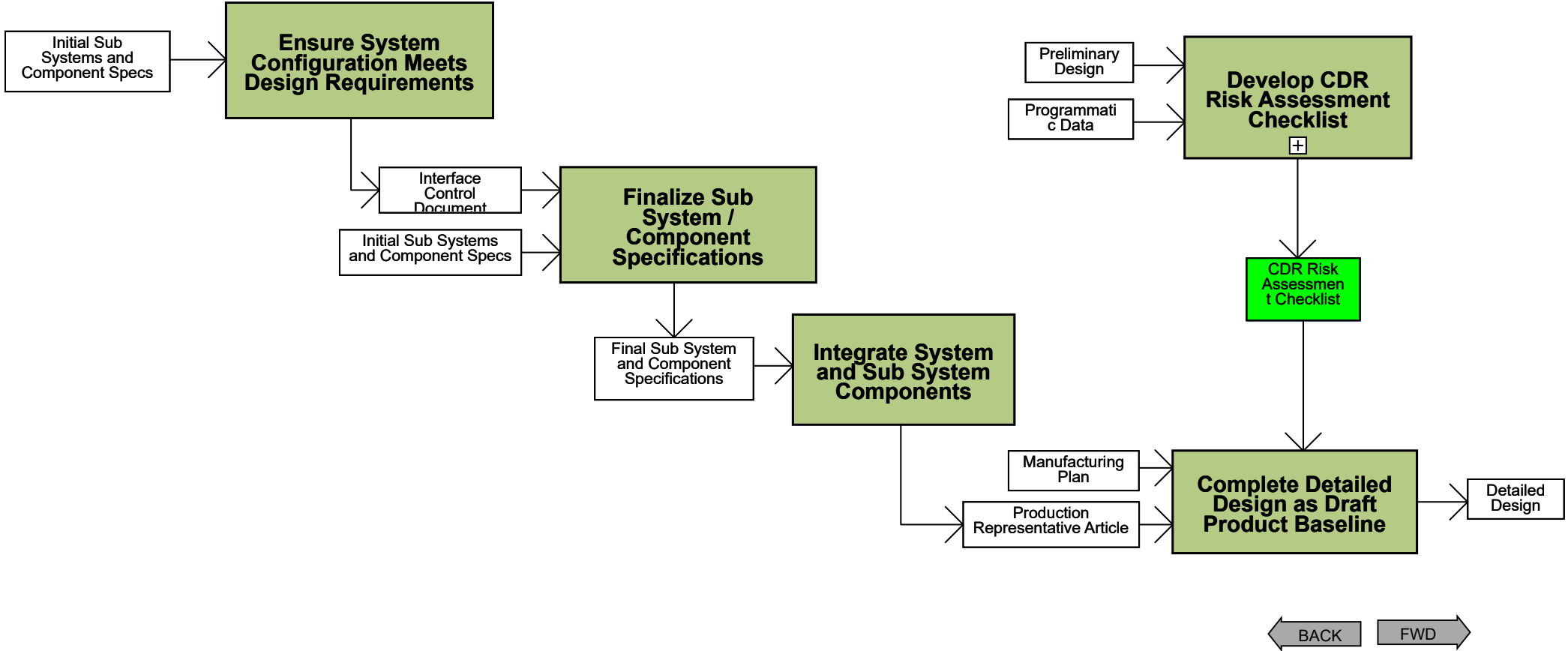

Go Up 1 Level

Acquisition Process Model

1.4.1.1.2.4 Develop CDR Risk Assessment Checklist

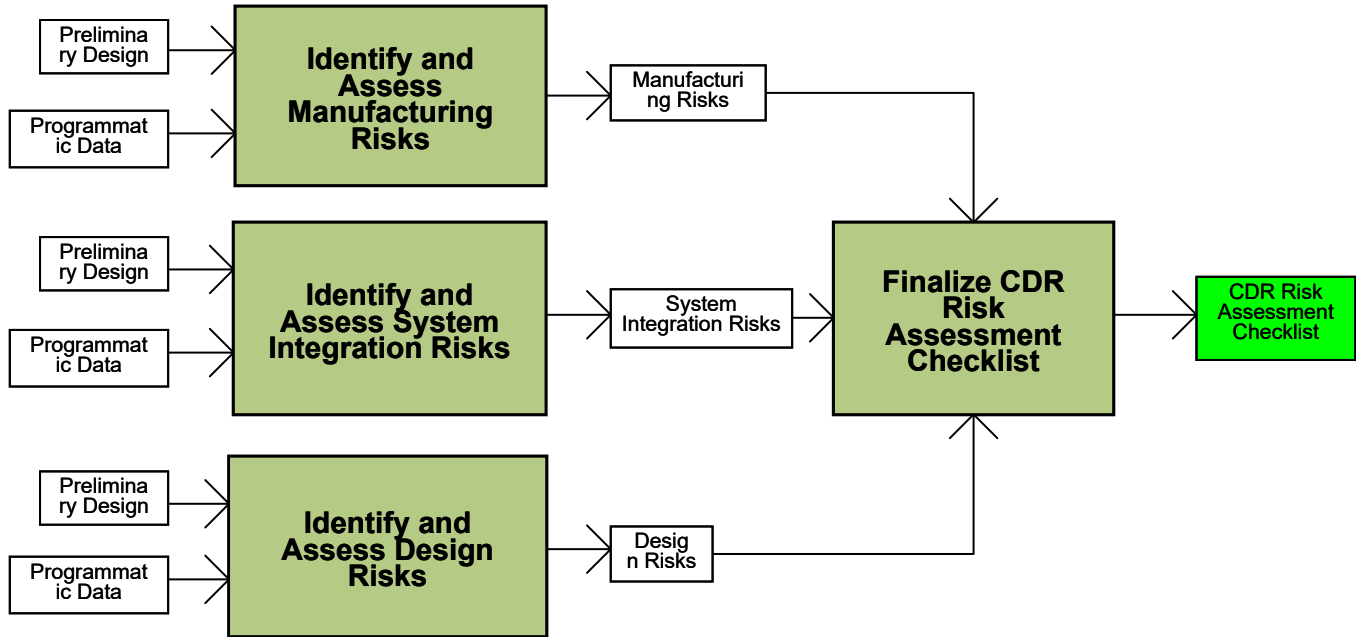

Go Up 1 Level

Acquisition Process Model

1.4.1.1.3 Address CDR (1.1.4.2)

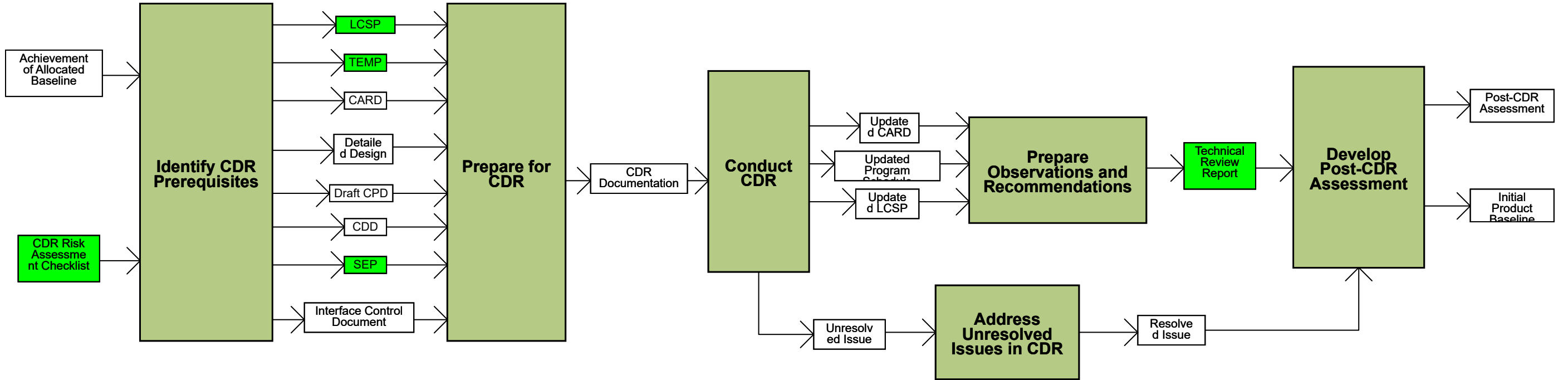

← BACK

Go Up 1 Level

Acquisition Process Model

1.4.1.2 Evaluate and Demonstrate the System

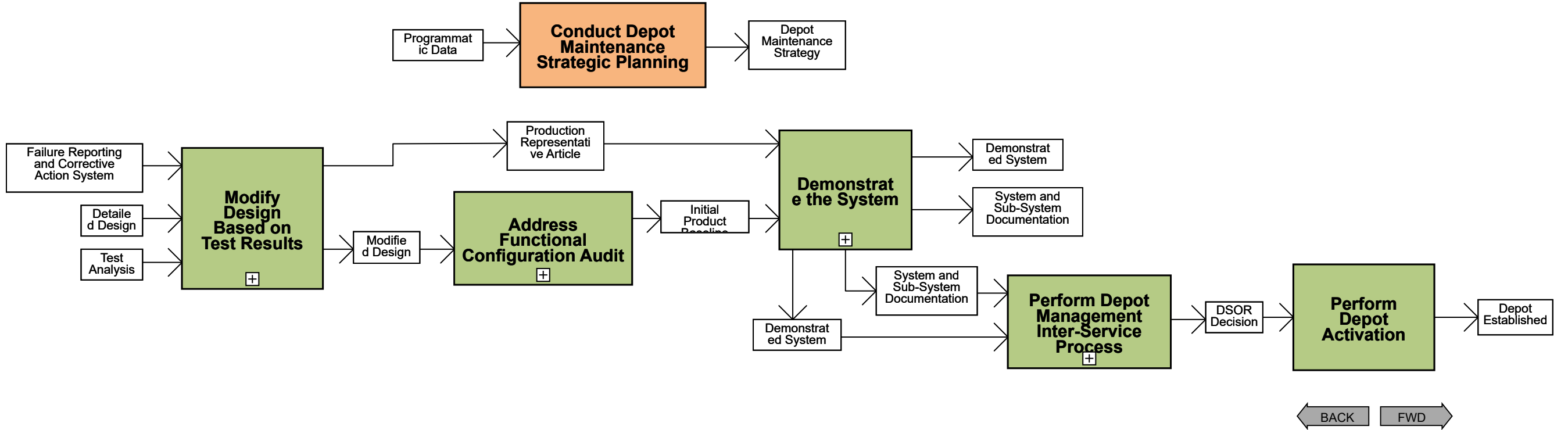

Acquisition Process Model

1.4.1.2.1 Modify Design Based on Test Results

Go Up 1 Level

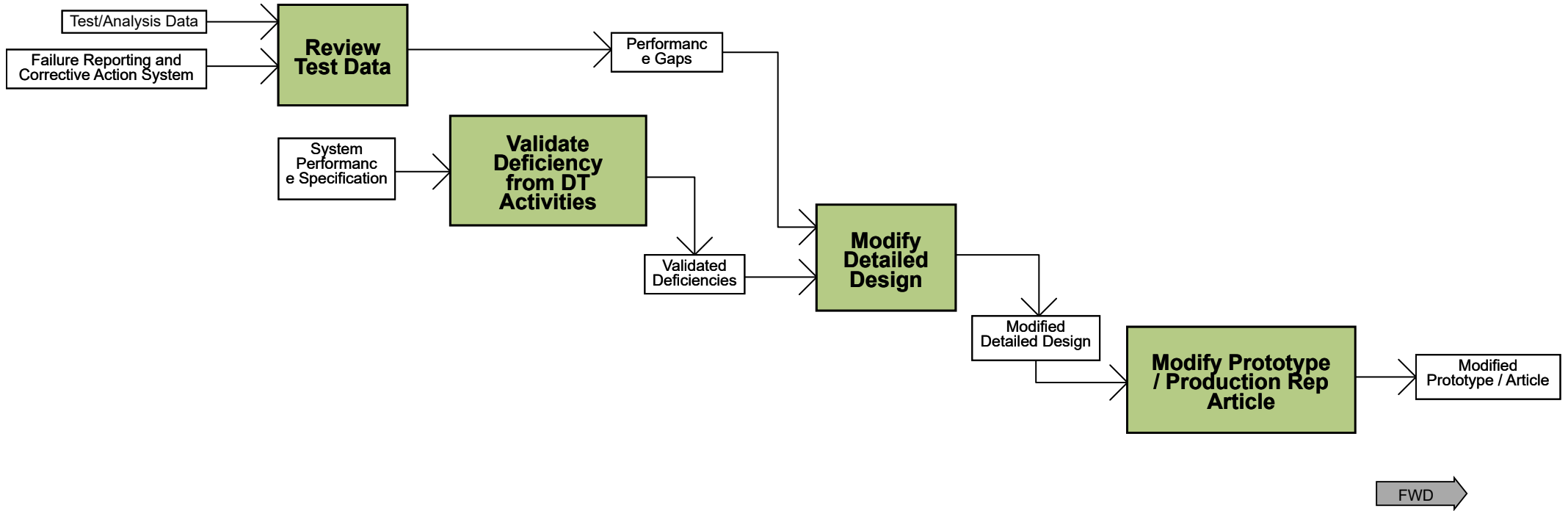

Go Up 1 Level

Acquisition Process Model

1.4.1.2.2 Address Functional Configuration Audit (FCA)

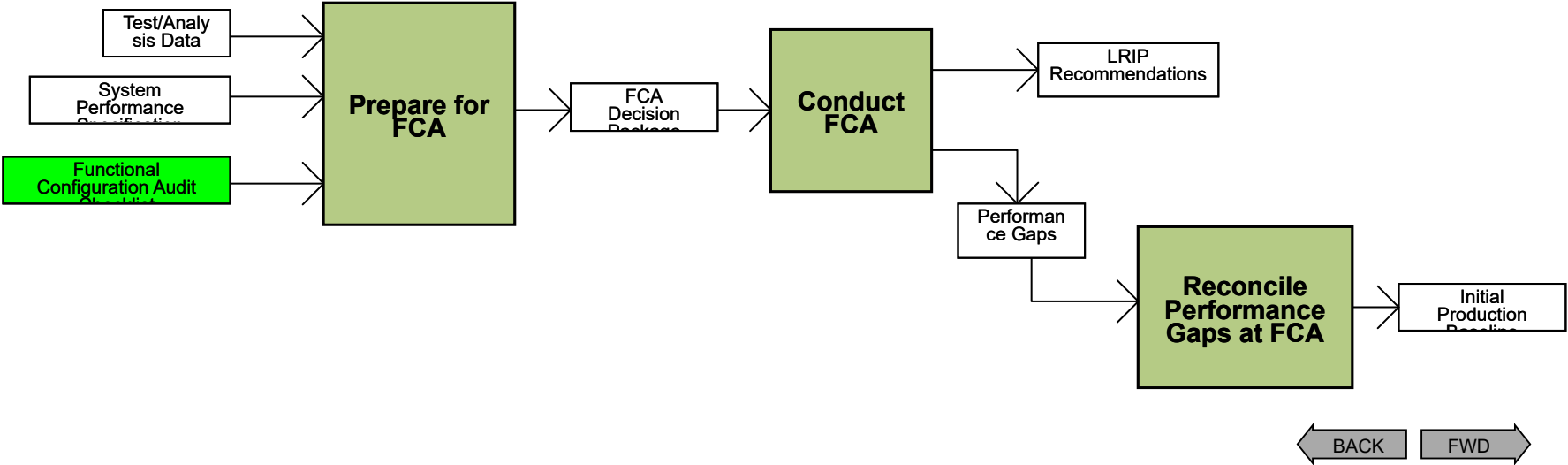

Go Up 1 Level

Acquisition Process Model

1.4.1.2.3 Demonstrate the System

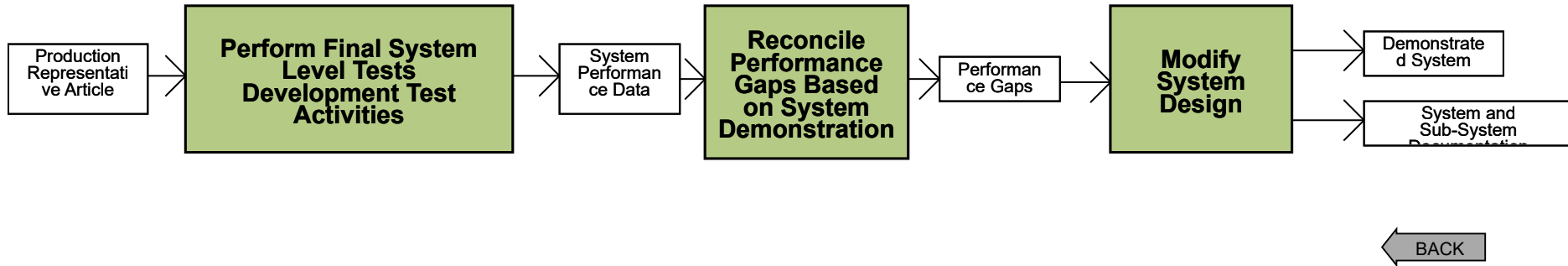

Go Up 1 Level

Acquisition Process Model

1.4.1.2.4 Perform Depot Management Inter-Service Process

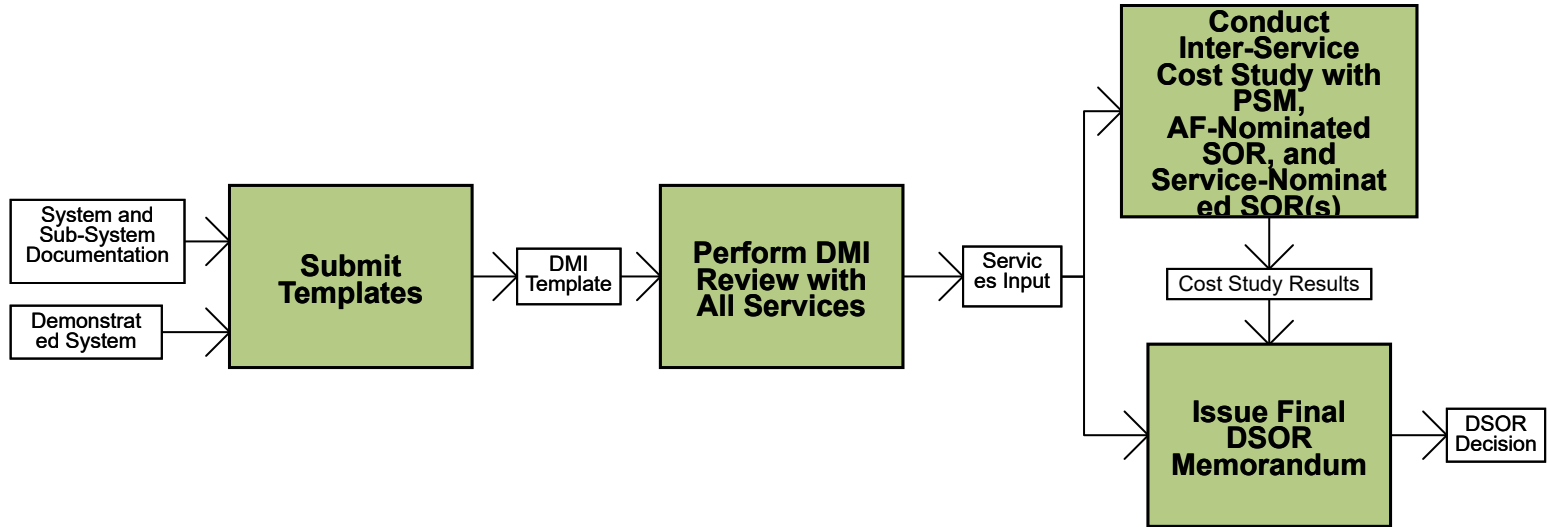

Go Up 1 Level

Acquisition Process Model

1.4.1.3 Demonstrate Manufacturing Readiness

PEO View

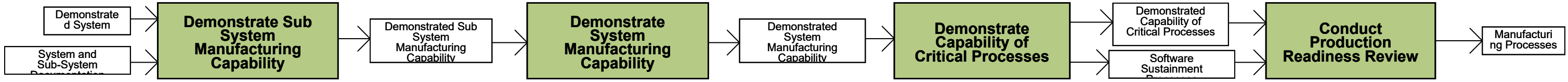

BACK FWD

Acquisition Process Model

1.4.1.4 Develop Capability Production Document (CPD)

Go Up 1 Level

PEO View

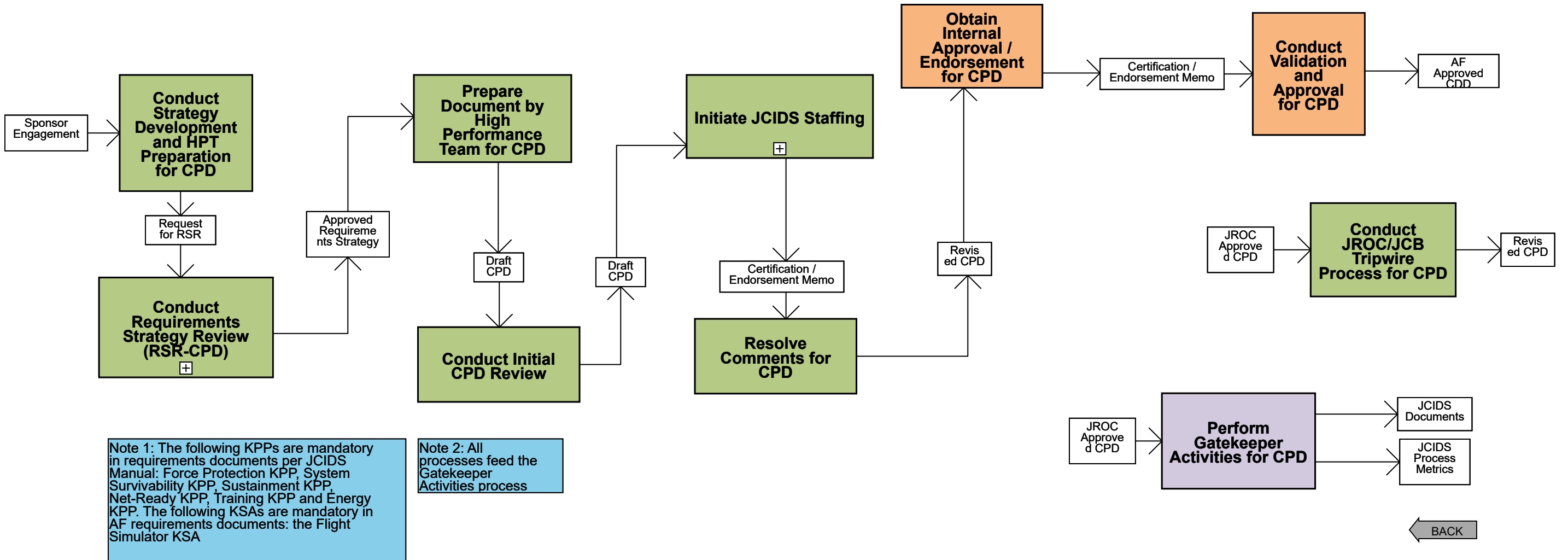

Go Up 1 Level

Acquisition Process Model

1.4.1.4.2 Conduct Requirements Strategy Review (RSR-CPD)

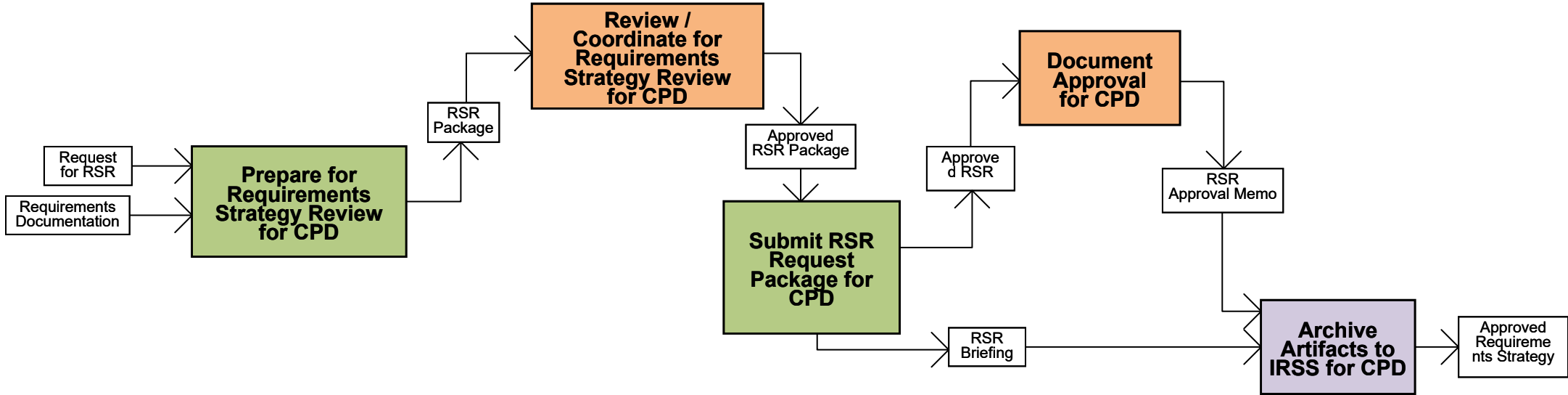

Go Up 1 Level

Acquisition Process Model

1.4.2 Program Production

PEO View

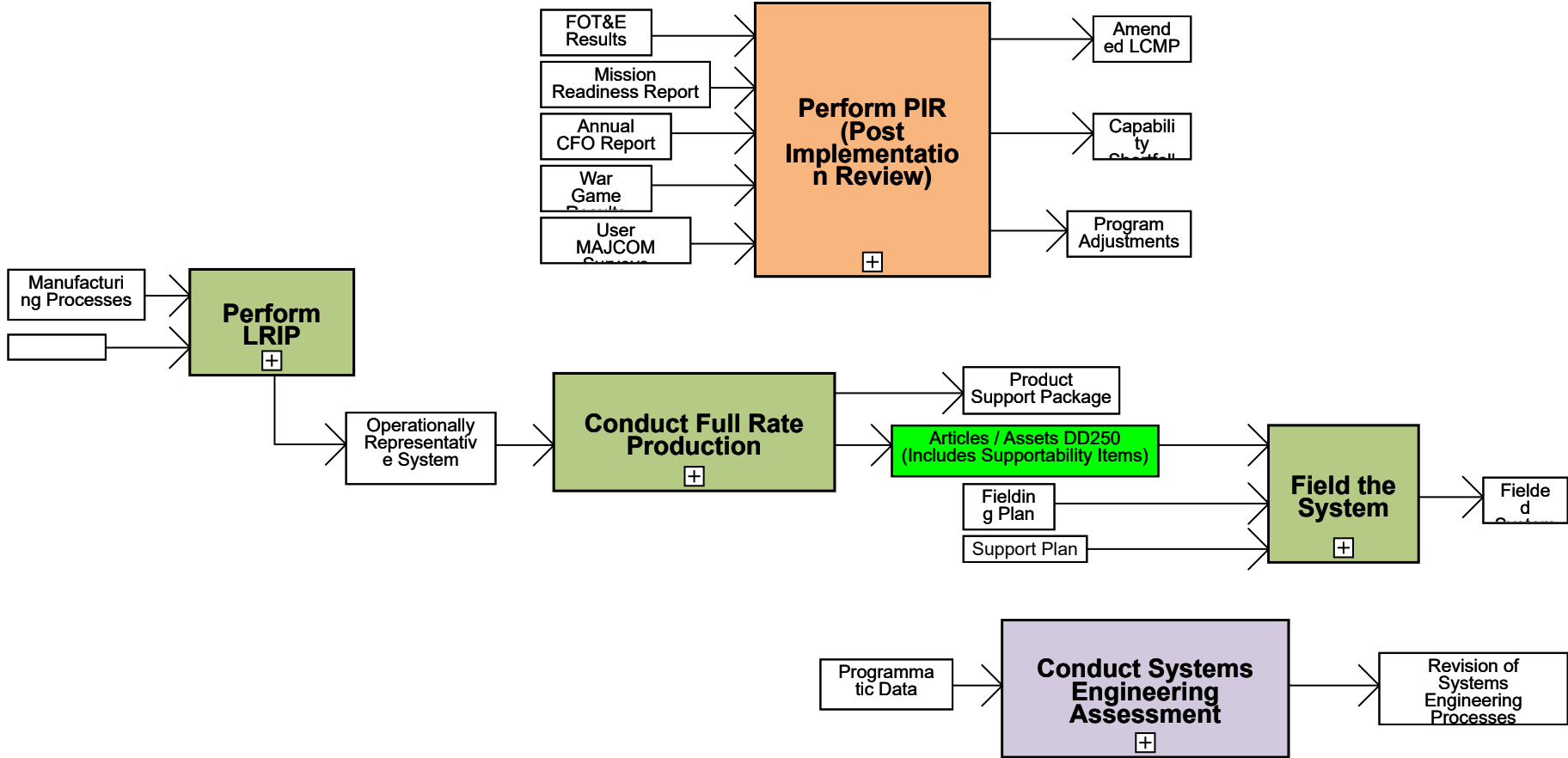

Note 1: The following websites provide valuable information for product support activities. The DoD Integrated Product Support Implementation Roadmap has links to over 2500 knowledge items (such as policy, references, and continuous learning modules). The Roadmap identifies activities and outputs for the twelve integrated product support (IPS) elements over the total life cycle. DoD has also established a Product Support Manager website that provides links to a variety of relevant documents. Finally, the Air Force has developed the Contract Sustainment Support Guide to provide best practices for contractor logistics support. Click here to access an active link to each of the above.

Note 2: This enabling process is based on the AFMC/EN and SMC/EN sponsored SEAM Guide.

Note 3: Enclosure 14, Sections 4 and 7 of DoDI 5000.02 provide a list of actions that RDT&E Organizations / Program Managers should take relative to Cybersecurity. Click here to access an active link to the instruction.

← BACK FWD →

Go Up 1 Level

Acquisition Process Model

1.4.2.1 Perform Low Rate Initial Production

PEO View

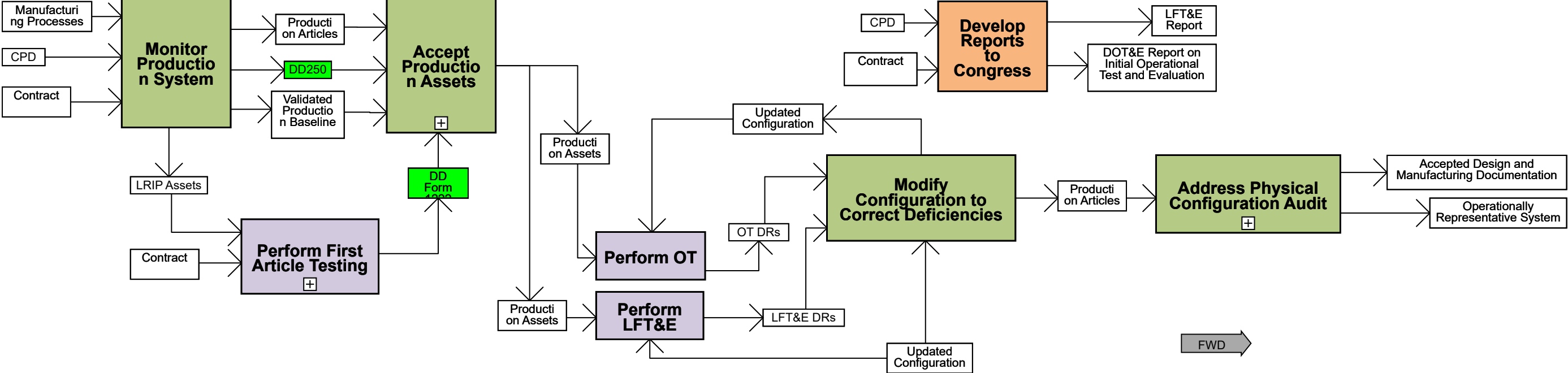

Acquisition Process Model

1.4.2.1.2 Perform First Article Testing (FAT)

Go Up 1 Level

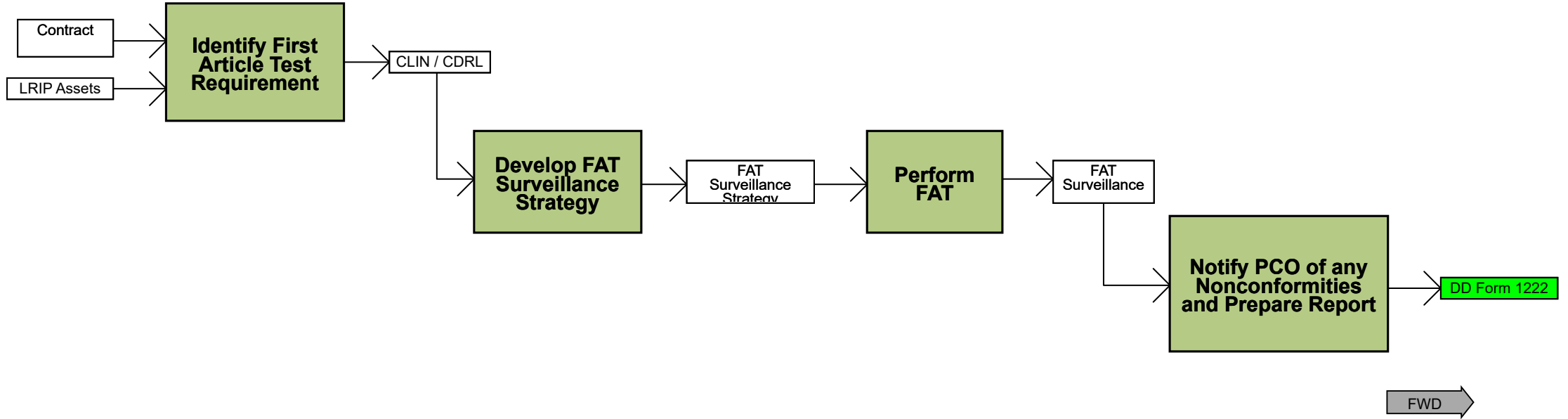

Go Up 1 Level

Acquisition Process Model

1.4.2.1.3 Accept Production Assets

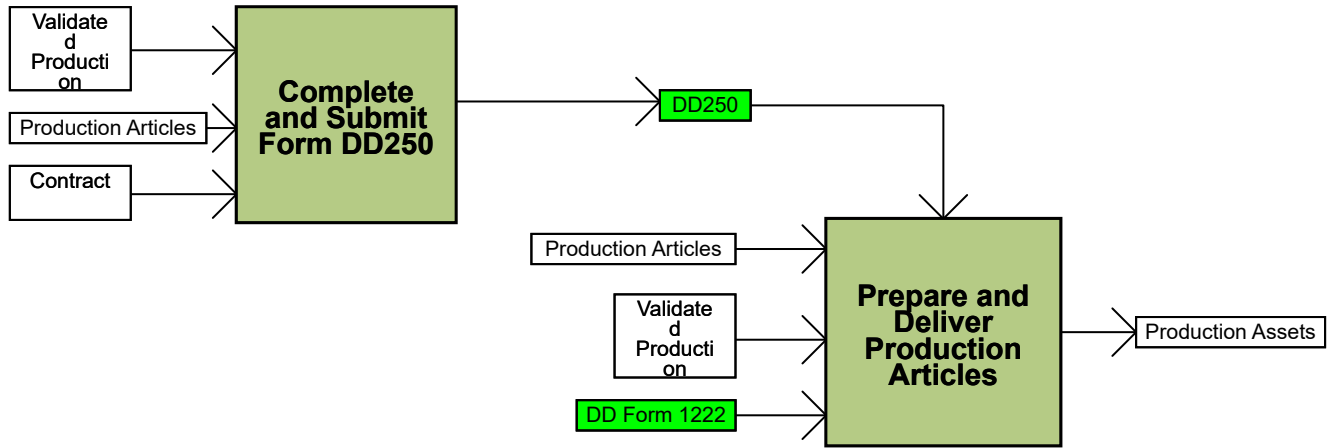

BACK FWD

Go Up 1 Level

Acquisition Process Model

1.4.2.1.7 Address Physical Configuration Audit (PCA)

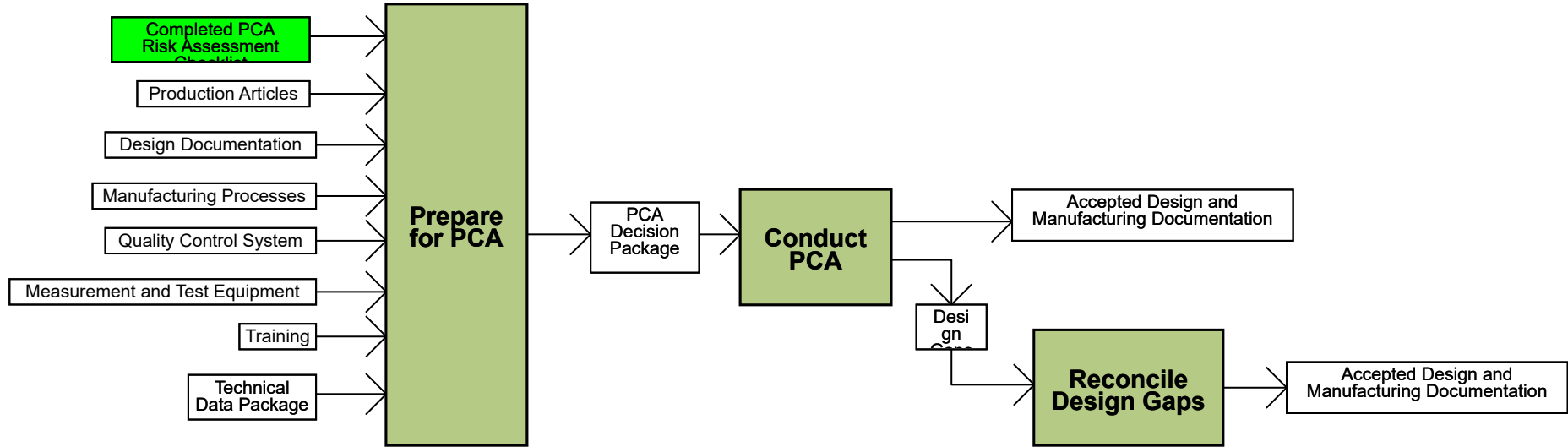

← BACK

Go Up 1 Level

Acquisition Process Model

1.4.2.2 Conduct Full Rate Production

PEO View

Full Rate Production Information Requirements

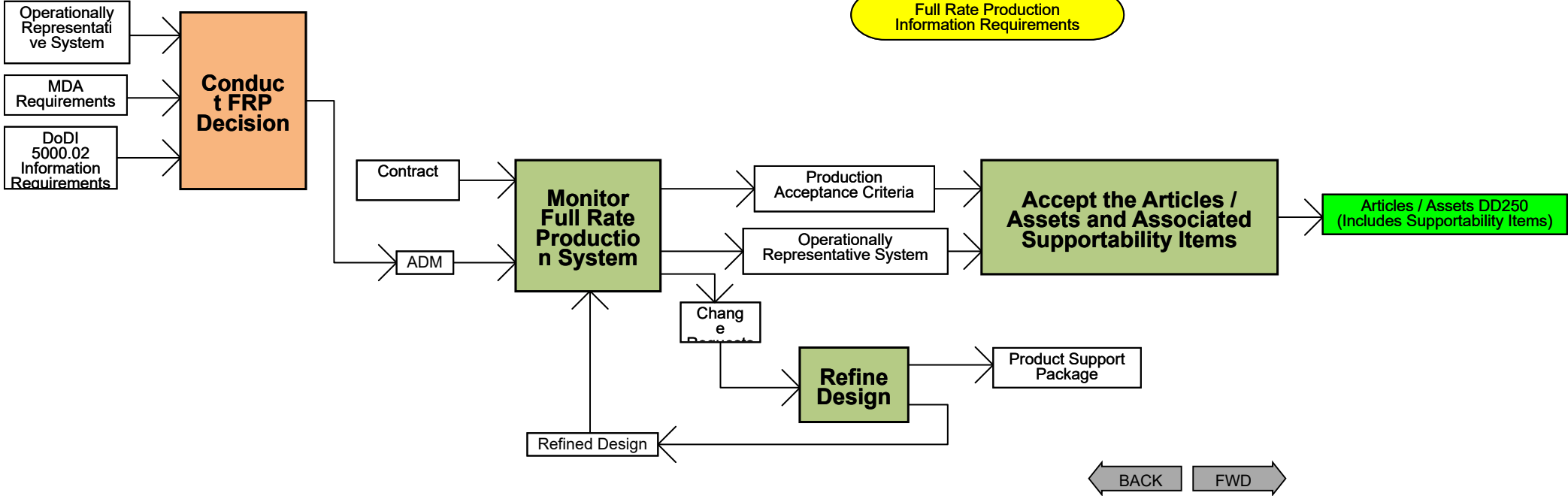

Acquisition Process Model

1.4.2.3 Field the System

PEO View

Go Up 1 Level

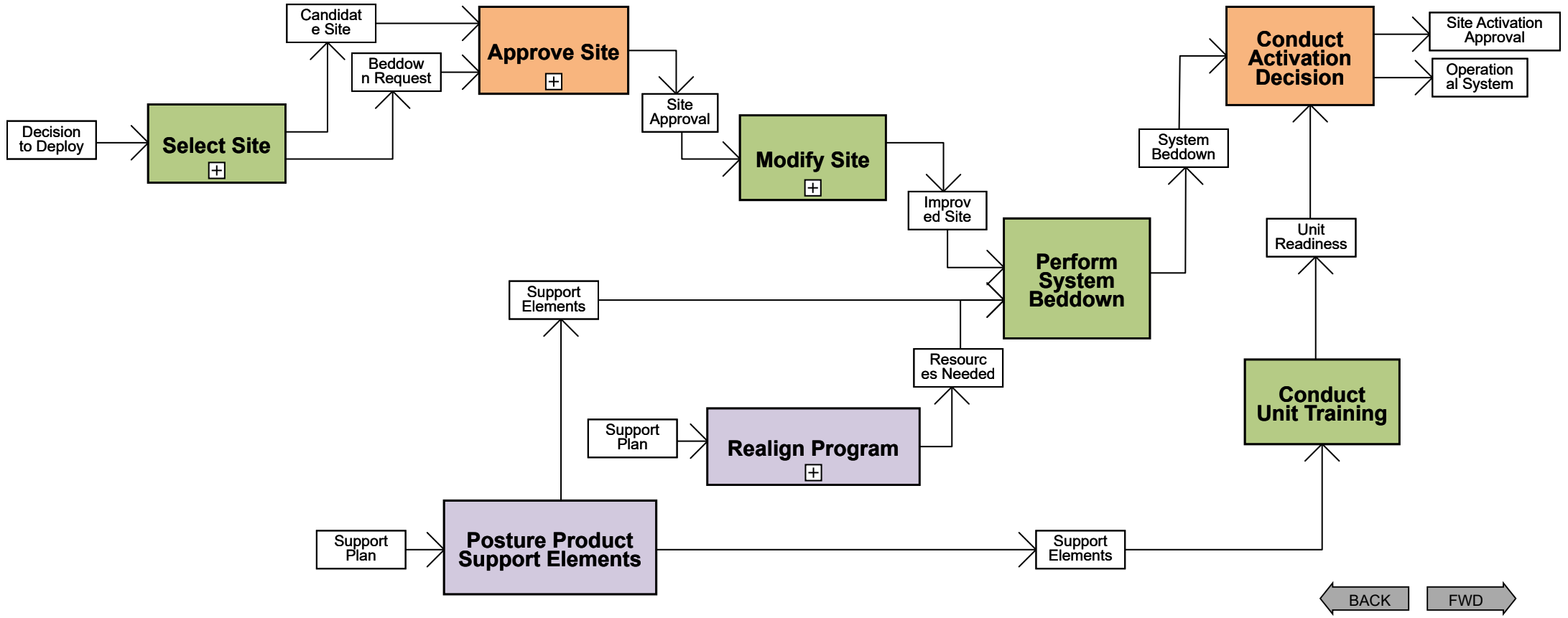

Go Up 1 Level

Acquisition Process Model

1.4.2.3.1 Select Site

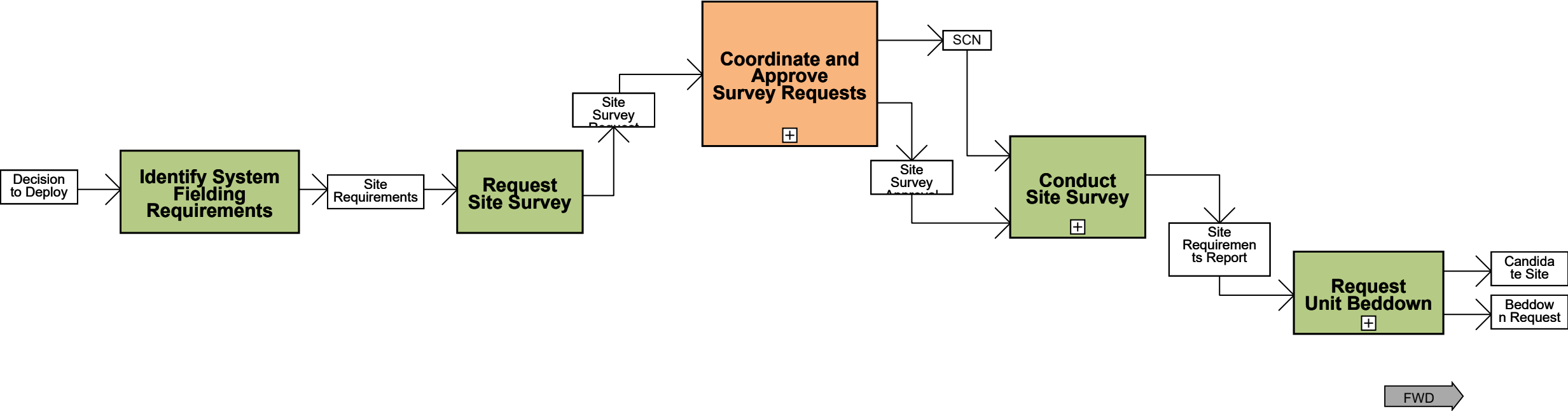

Go Up 1 Level

Acquisition Process Model

1.4.2.3.1.3 Coordinate and Approve Survey Requests

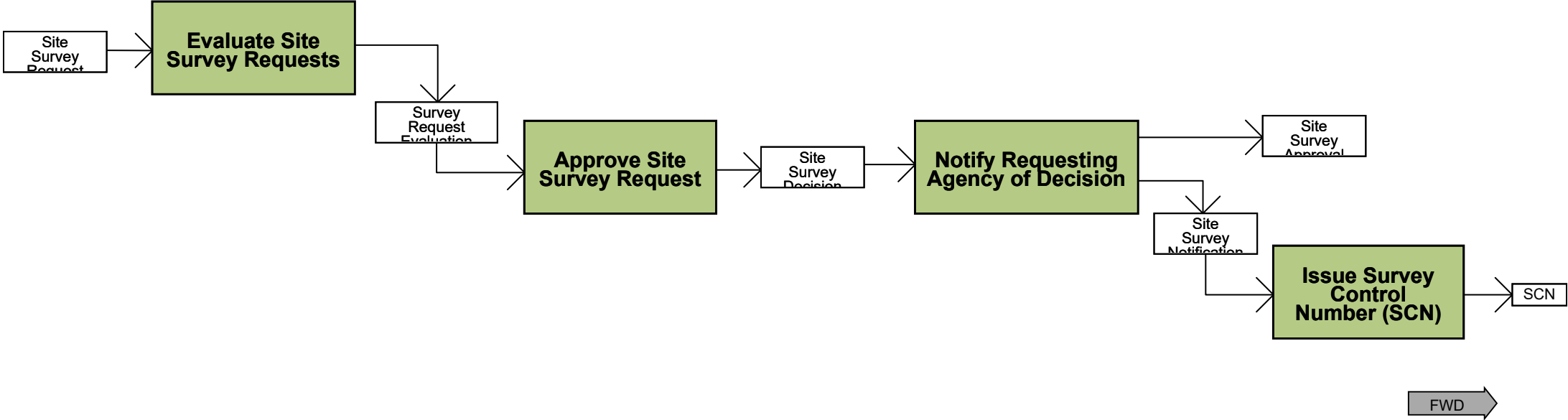

Acquisition Process Model

1.4.2.3.1.4 Conduct Site Survey

Go Up 1 Level

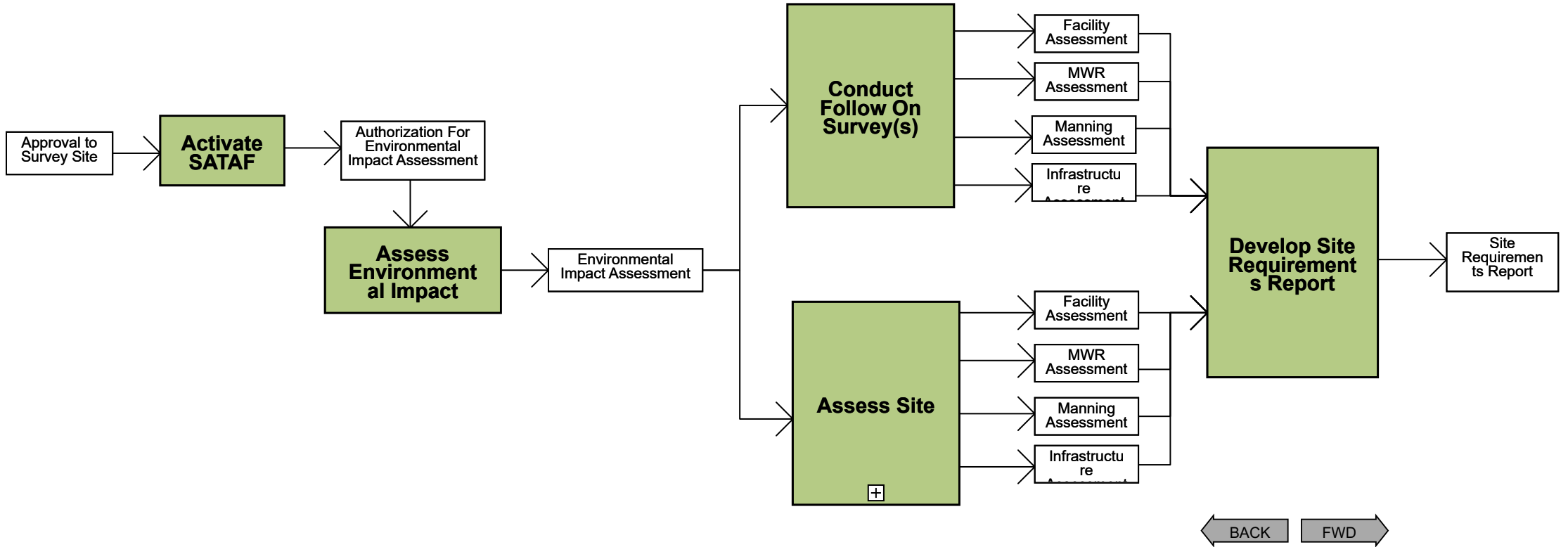

Go Up 1 Level

Acquisition Process Model

1.4.2.3.1.4.3 Assess Site

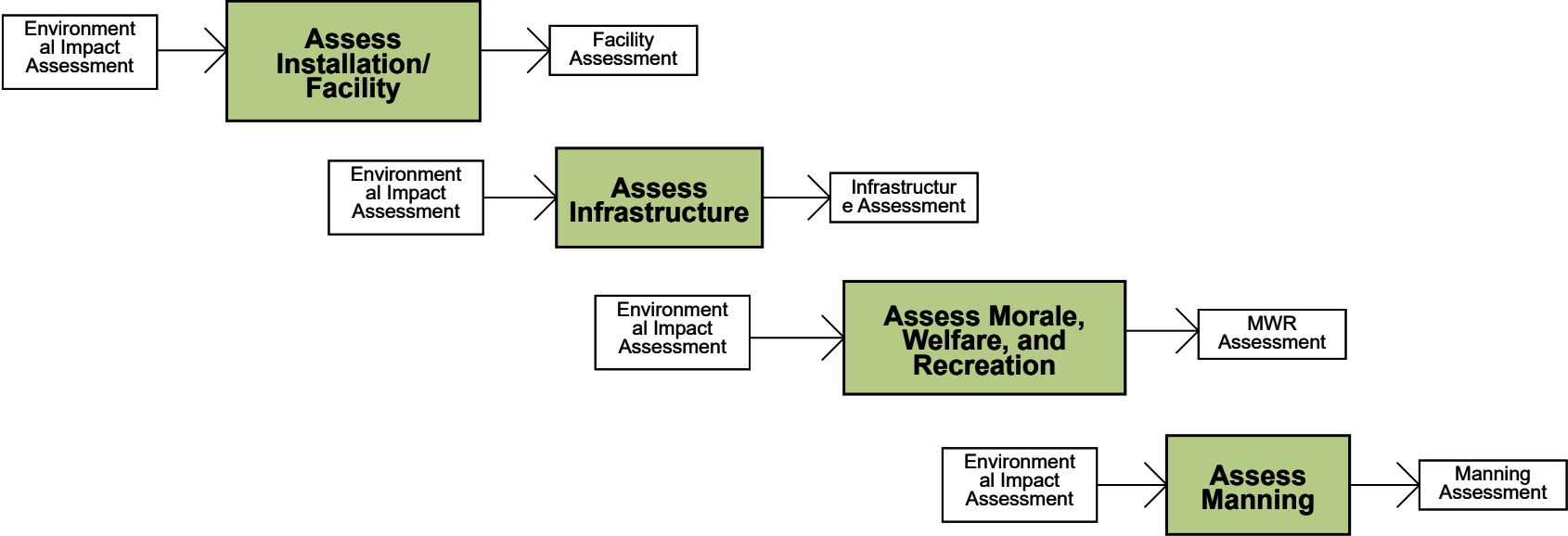

Go Up 1 Level

Acquisition Process Model

1.4.2.3.1.5 Request Unit Beddown

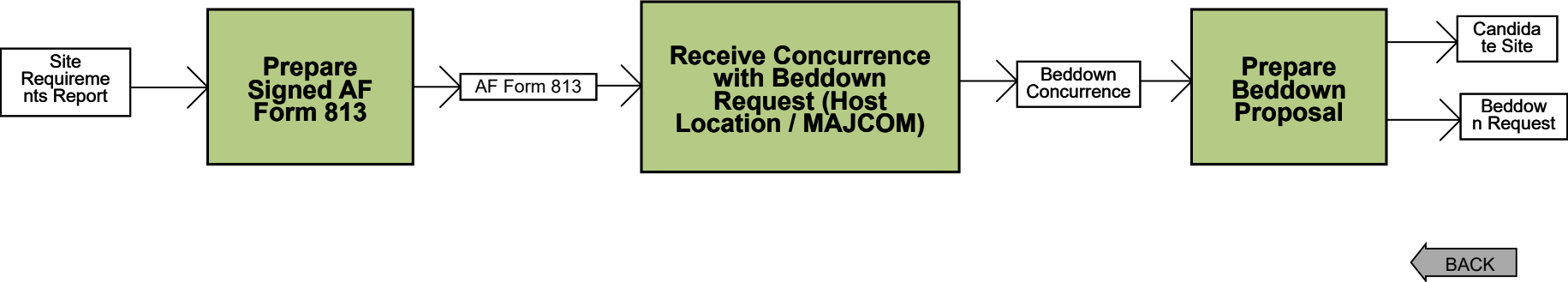



Acquisition Process Model

1.4.2.3.2 Approve Site

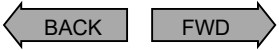
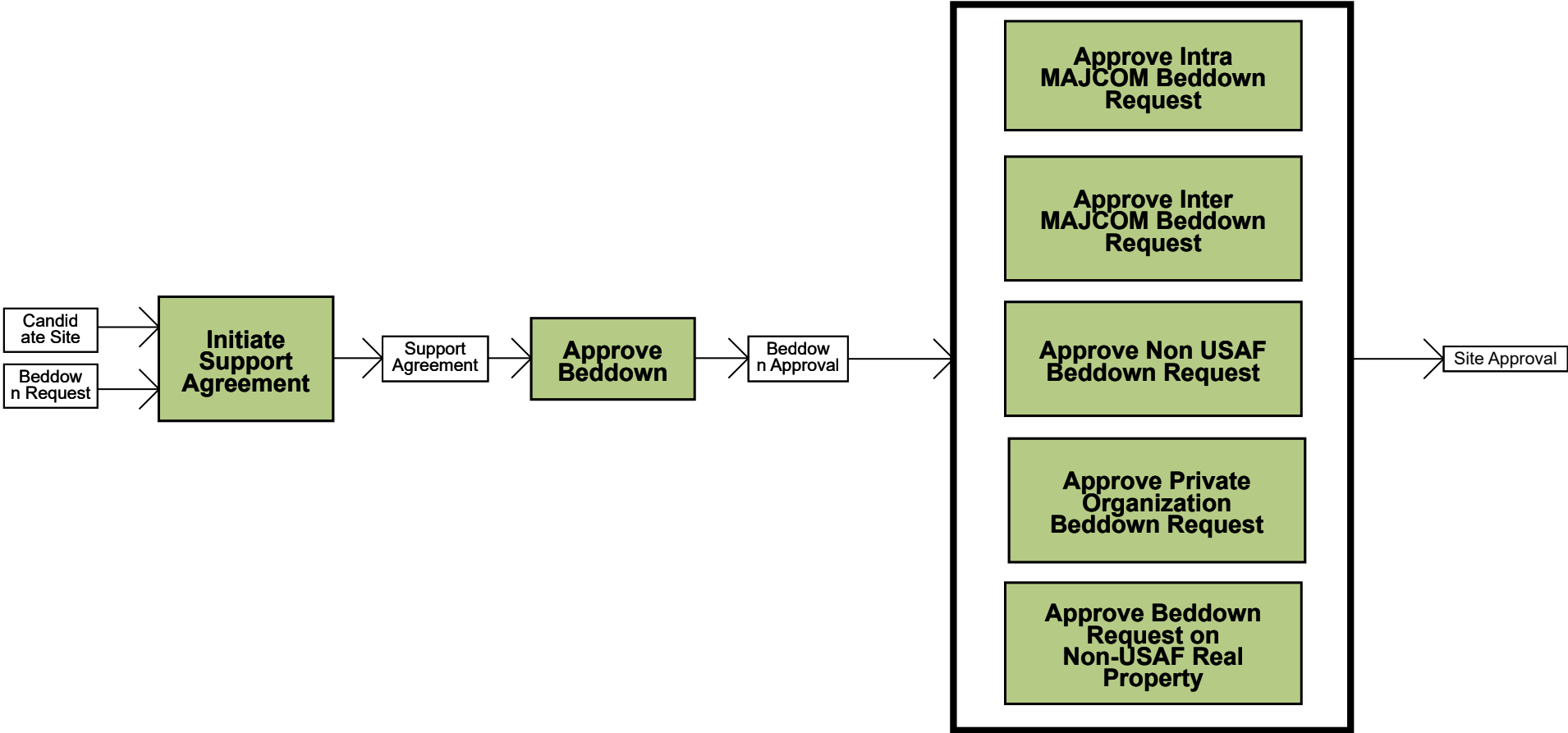

Go Up 1 Level

Acquisition Process Model

1.4.2.3.3 Modify Site

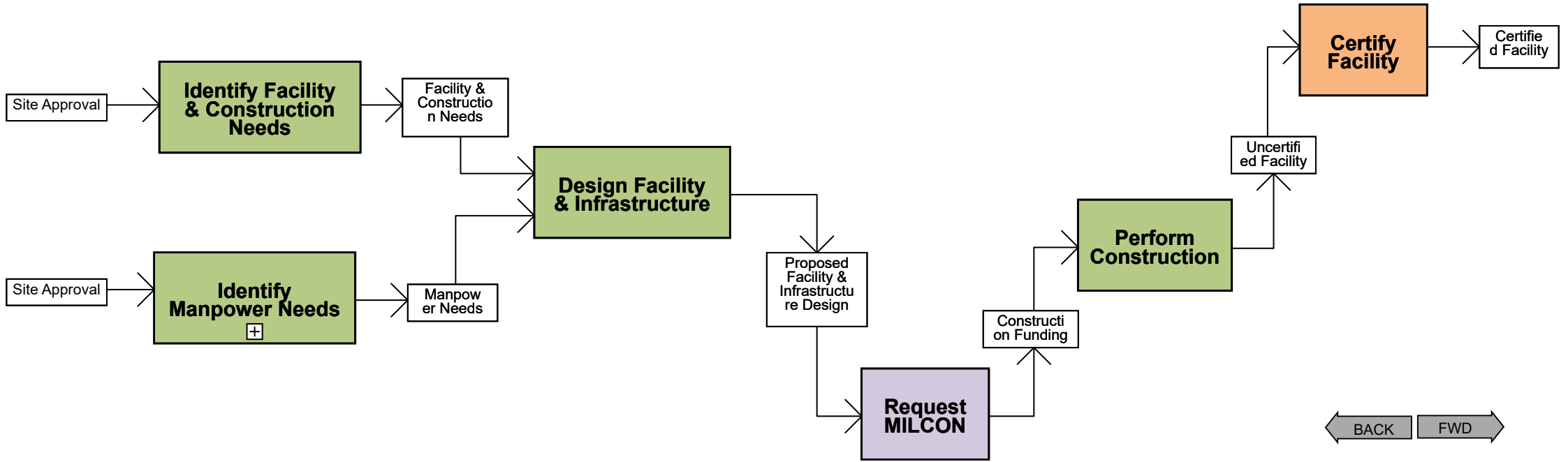

Go Up 1 Level

Acquisition Process Model

1.4.2.3.3.2 Identify Manpower Needs

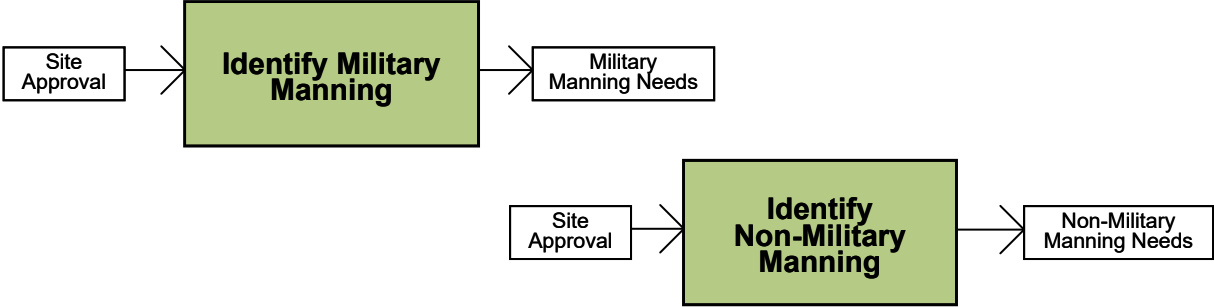

Go Up 1 Level

Acquisition Process Model

1.4.2.3.4 Realign Program

AFLCMC
Standard
Processes

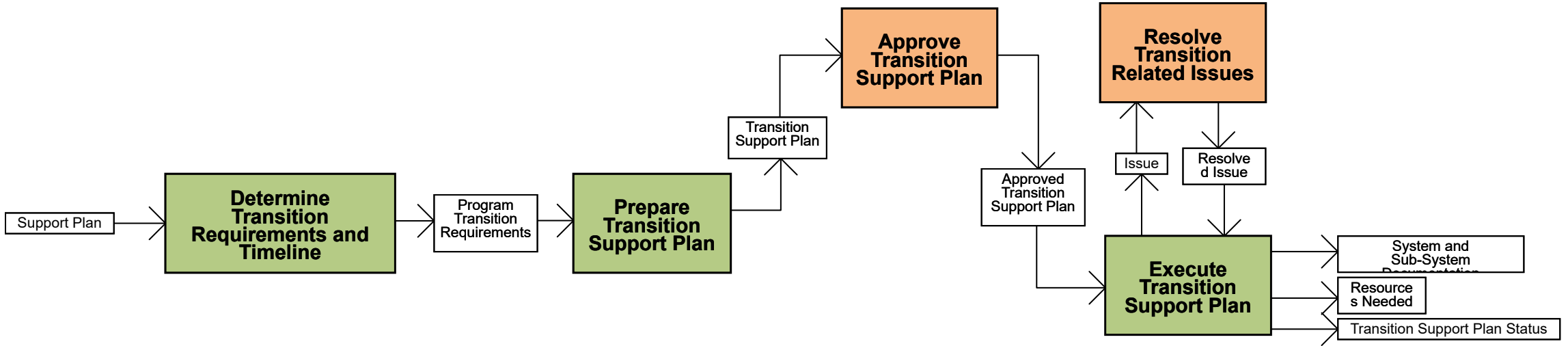

Note: Incorporated references to the AFLCMC Standard Process (Program Transition).

← BACK

Go Up 1 Level

Acquisition Process Model

1.4.2.4 Perform Post Implementation Review (PIR)

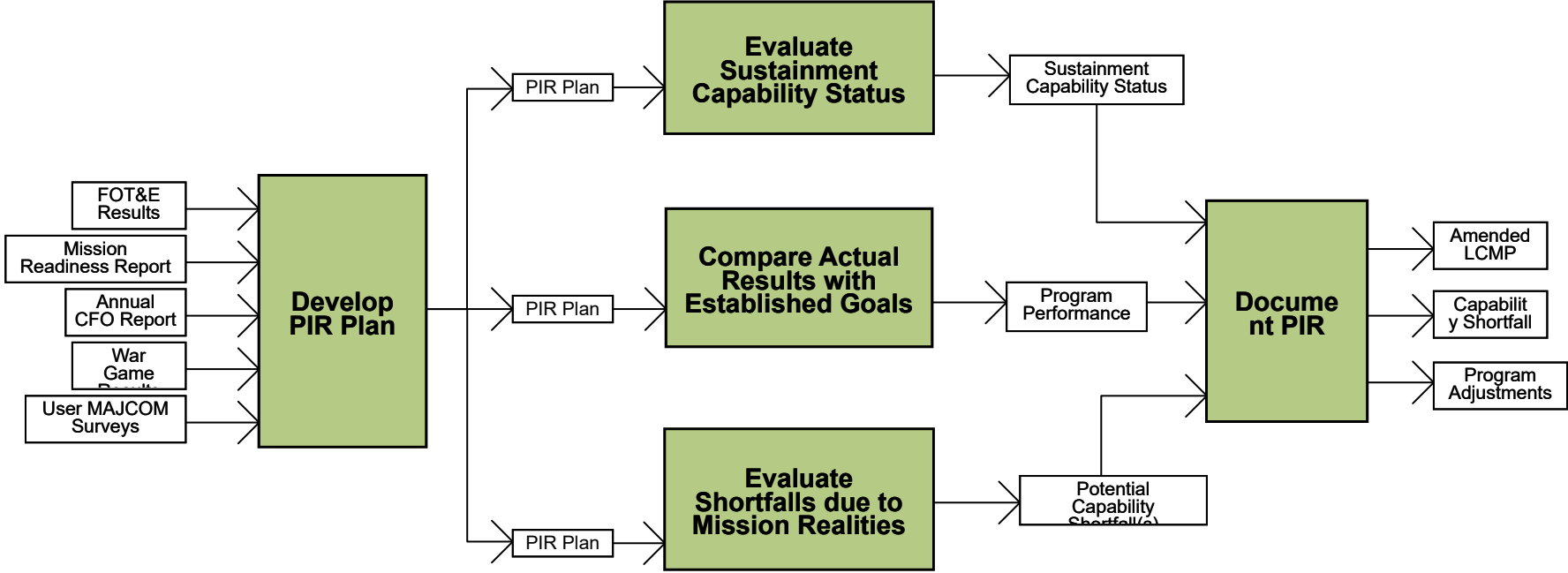

← BACK

Go Up 1 Level

Acquisition Process Model

1.4.3 System Sustainment

PEO View

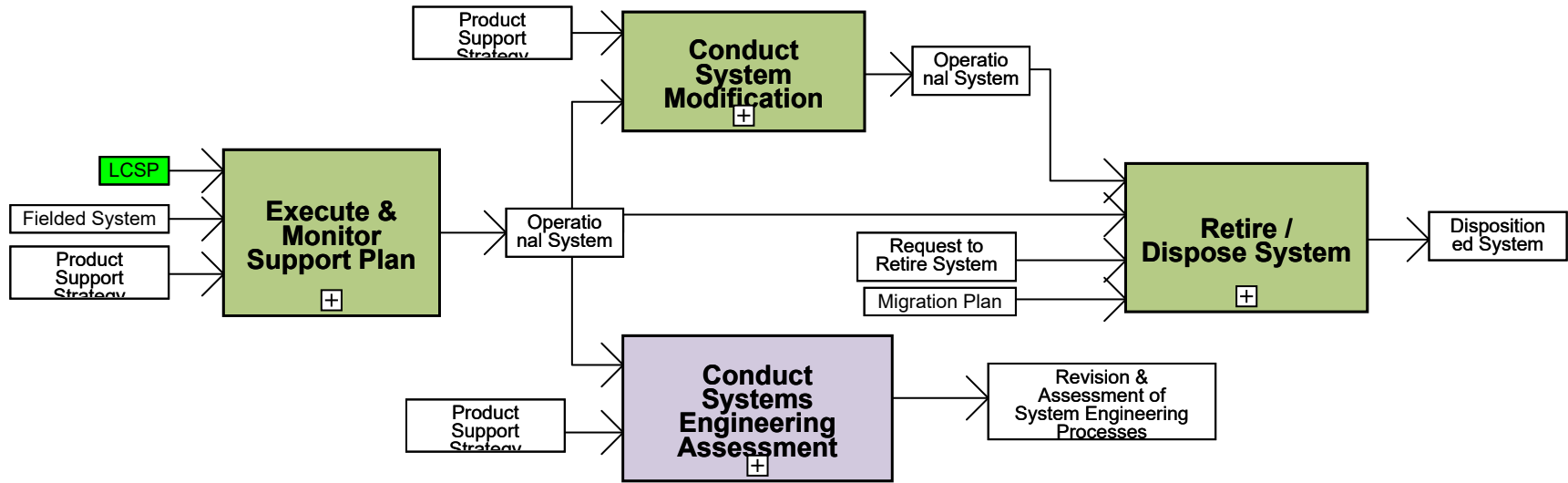

Note 1: The following websites provide valuable information for product support activities. The DoD Integrated Product Support Implementation Roadmap has links to over 2500 knowledge items (such as policy, references, and continuous learning modules). The Roadmap identifies activities and outputs for the twelve integrated product support (IPS) elements over the total life cycle. DoD has also established a Product Support Manager website that provides links to a variety of relevant documents. Finally, the Air Force has developed the Contract Sustainment Support Guide to provide best practices for contractor logistics support. Click here to access an active link to each of the above.

Note 2: The Conduct Systems Engineering Assessment process is based on the AFMC/EN and SMC/EN sponsored SEAM Guide.

Note 3: Enclosure 14, Sections 4 and 7 of DoDI 5000.02 provide a list of actions that RDT&E Organizations / Program Managers should take relative to Cybersecurity. Click here to access an active link to the instruction.

← BACK FWD →

Go Up 1 Level

Acquisition Process Model

1.4.3.1 Execute & Monitor Support Plan

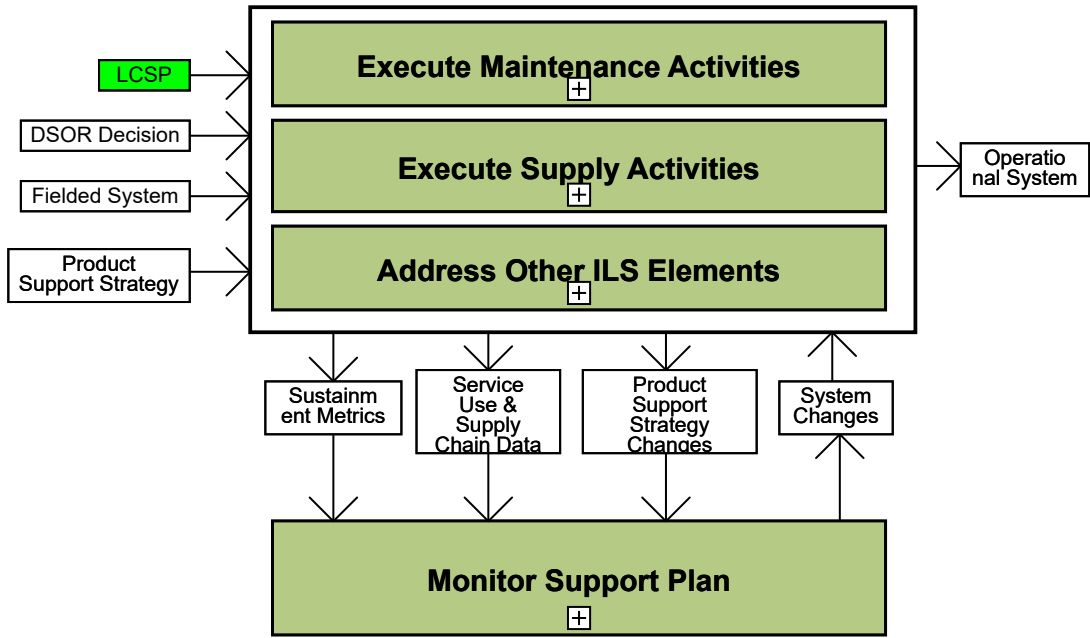

Note: The following websites provide valuable information for product support activities. The DoD Integrated Product Support Implementation Roadmap has links to over 2500 knowledge items (such as policy, references, and continuous learning modules). The Roadmap identifies activities and outputs for the twelve integrated product support (IPS) elements over the total life cycle. DoD has also established a Product Support Manager website that provides links to a variety of relevant documents. Finally, the Air Force has developed the Contract Sustainment Support Guide to provide best practices for contractor logistics support. Click here to access an active link to each of the above.

FWD →

Go Up 1 Level

Acquisition Process Model

1.4.3.1.1 Execute Maintenance Activities

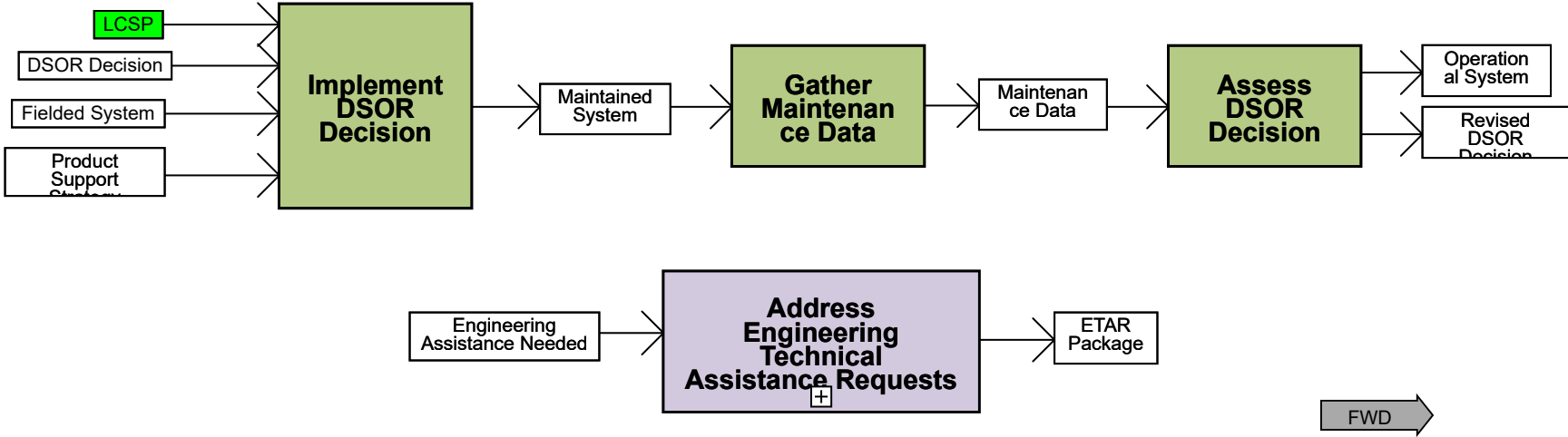

Go Up 1 Level

Acquisition Process Model

1.4.3.1.1.4 Address Engineering Technical Assistance Requests

AFLCMC
Standard
Processes

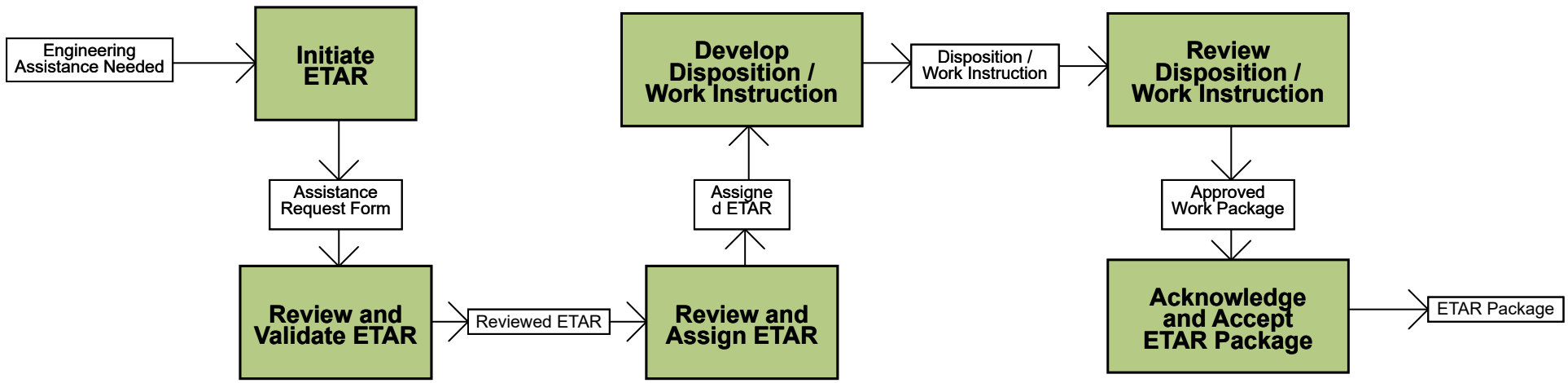

Note: This is an AFLCMC Standard Process

Go Up 1 Level

Acquisition Process Model

1.4.3.1.2 Execute Supply Activities

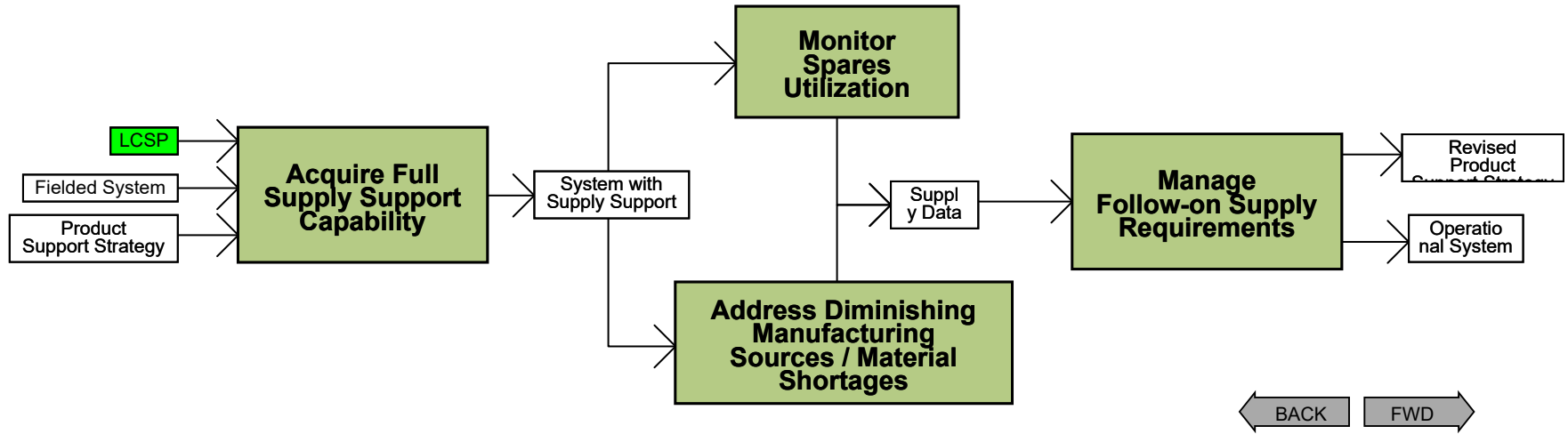

Go Up 1 Level

Acquisition Process Model

1.4.3.1.3.1 Execute PHS&T Activities

AFLCMC
Standard
Processes

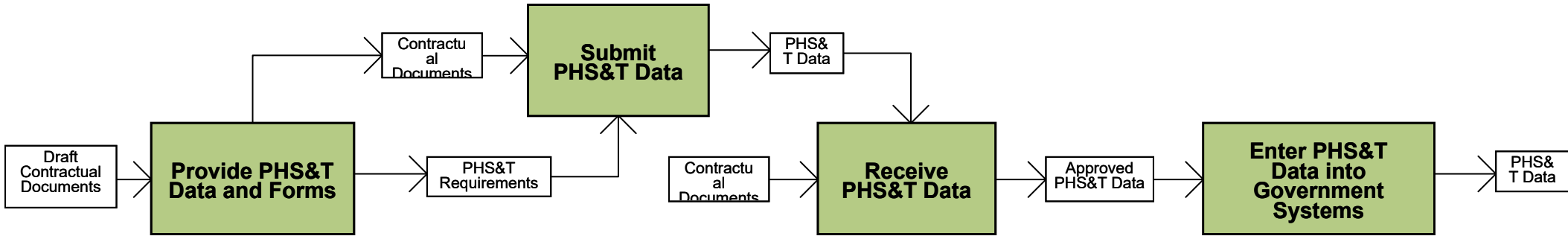

Note: This is an AFLCMC Standard Process. Steps 1.1-1.3 and 1.5-1.9 of this process are reflected within 1.4.4 Contract Management.

Go Up 1 Level

Acquisition Process Model

1.4.3.1.4 Monitor Support Plan

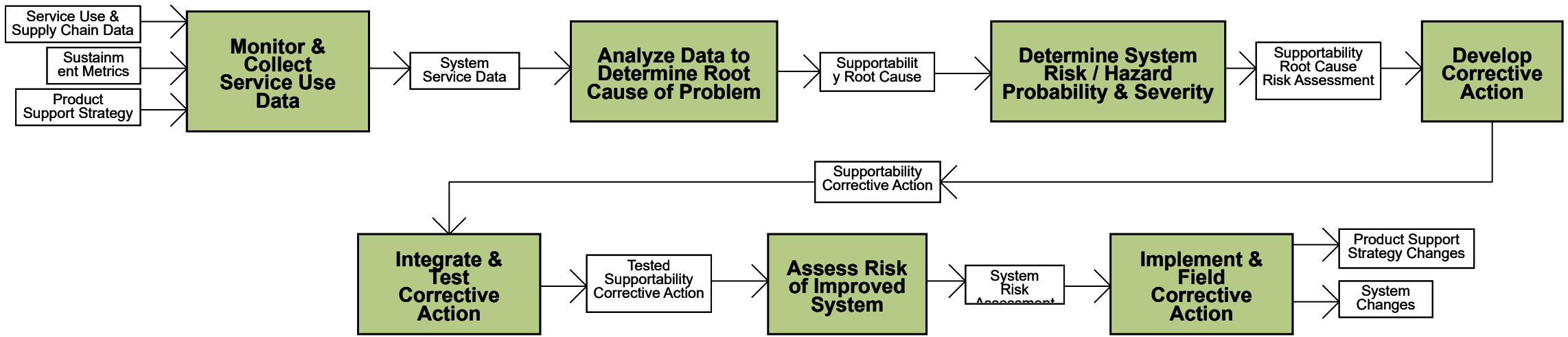

BACK

Go Up 1 Level

Acquisition Process Model

1.4.3.2 System Modification

PEO View

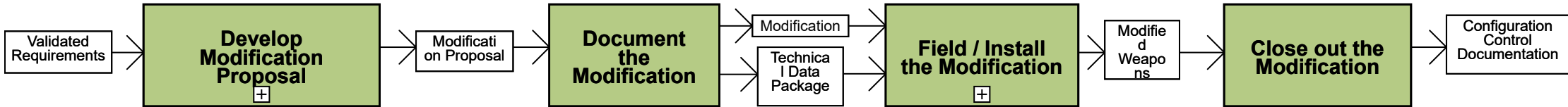

Note: The enabling process receives information from all of the core processes. For display purposes, we have not shown these

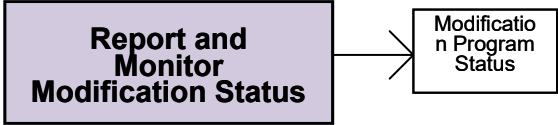

Go Up 1 Level

Acquisition Process Model

1.4.3.2.1 Develop Modification Proposal

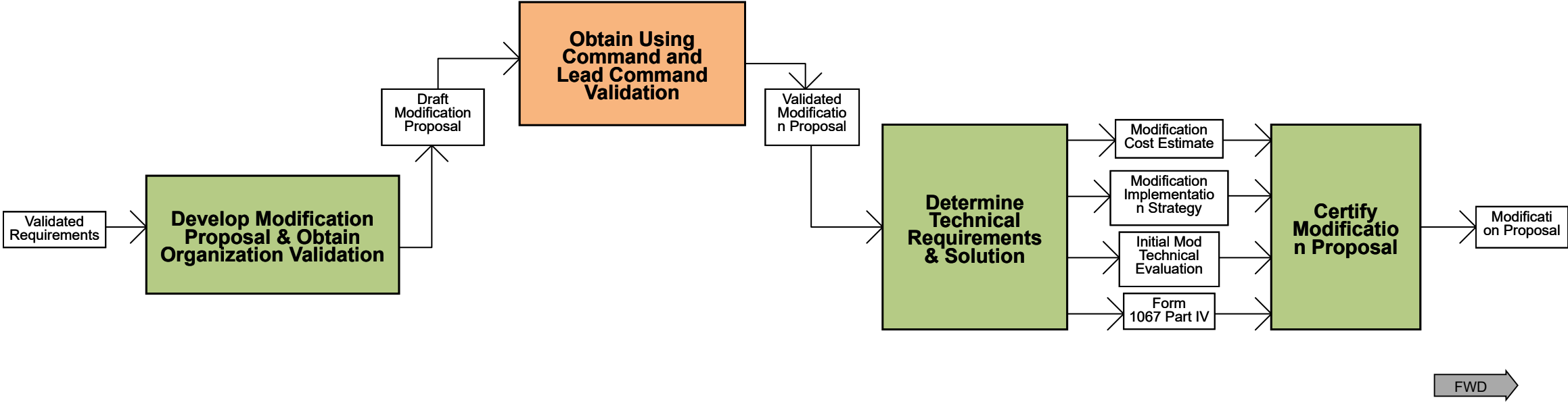

Go Up 1 Level

Acquisition Process Model

1.4.3.2.3 Field the Modification

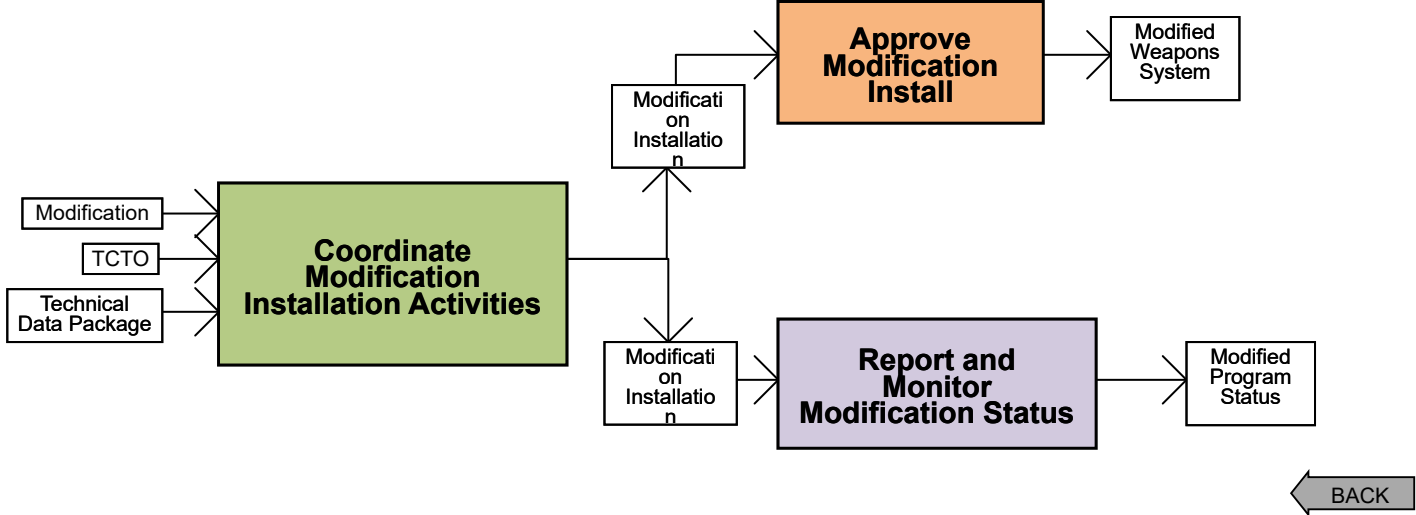

Acquisition Process Model

1.4.3.3 Conduct SEAM

Go Up 1 Level

PEO View

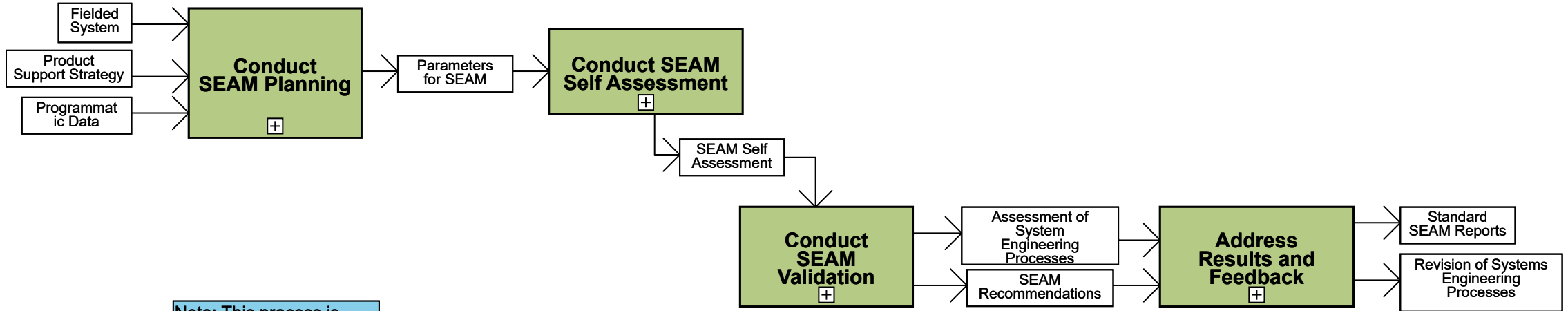

Note: This process is based on the AFMC/EN and SMC/EN sponsored SEAM Guide.

BACK FWD

Go Up 1 Level

Acquisition Process Model

1.4.3.3.1 Conduct SEAM Planning

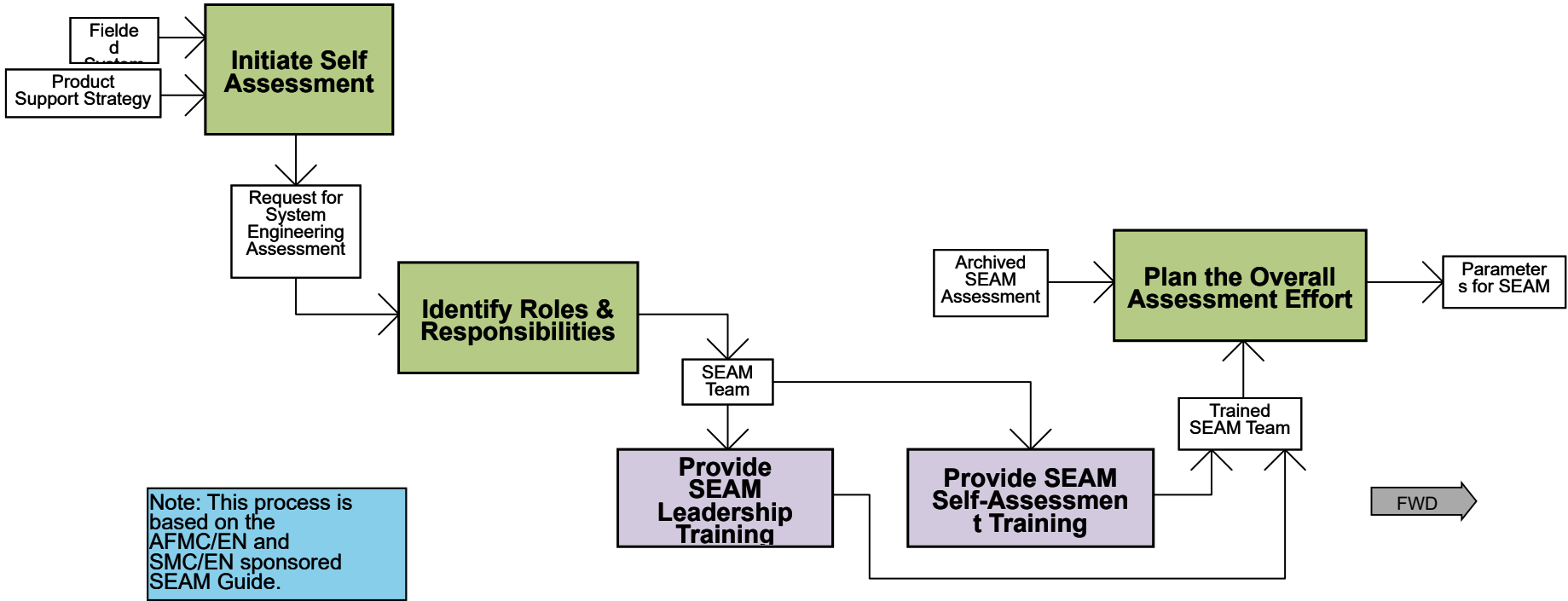

Go Up 1 Level

Acquisition Process Model

1.4.3.3.2 Conduct SEAM Self Assessment

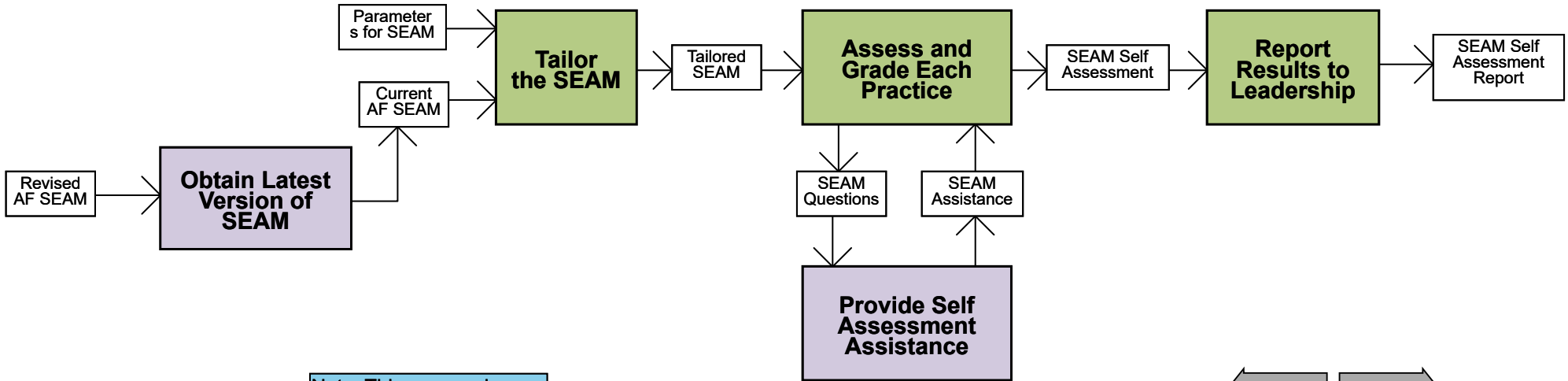

Note: This process is based on the AFMC/EN and SMC/EN sponsored SEAM Guide.

← BACK FWD →

Go Up 1 Level

Acquisition Process Model

1.4.3.3 Conduct SEAM Validation

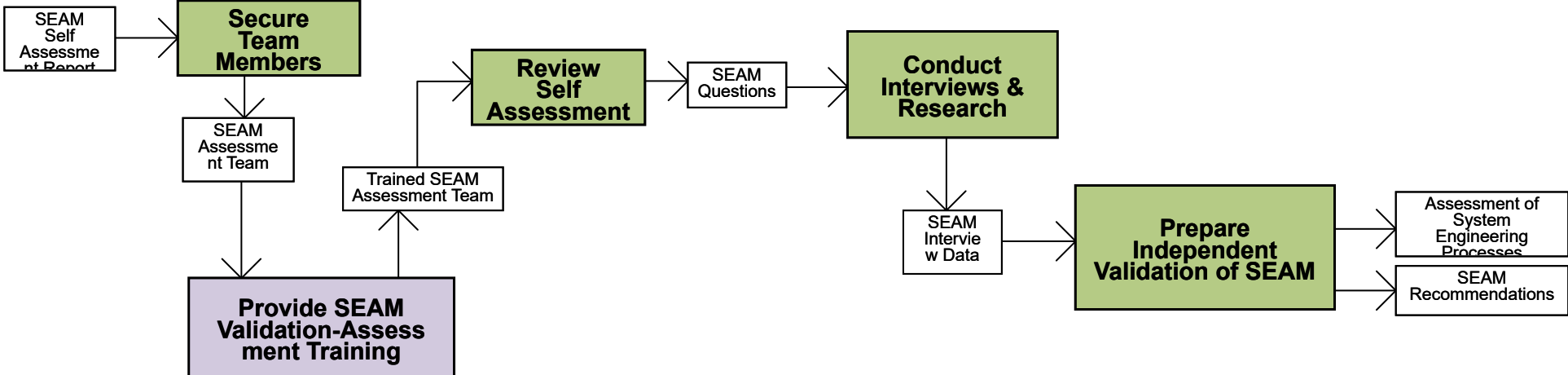

Note: This process is based on the AFMC/EN and SMC/EN sponsored SEAM Guide.

← BACK FWD →

Go Up 1 Level

Acquisition Process Model

1.4.3.3.4 Address Results and Feedback

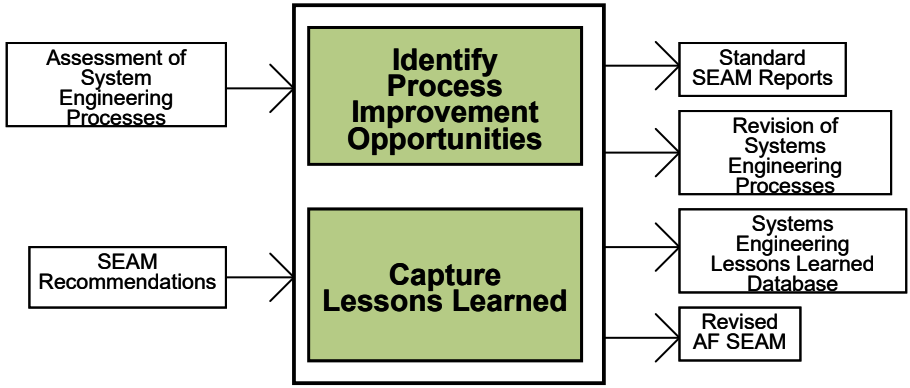

Note: This process is based on the AFMC/EN and SMC/EN sponsored SEAM Guide.

← BACK

Go Up 1 Level

Acquisition Process Model

1.4.3.4 Retire Dispose System

PEO View

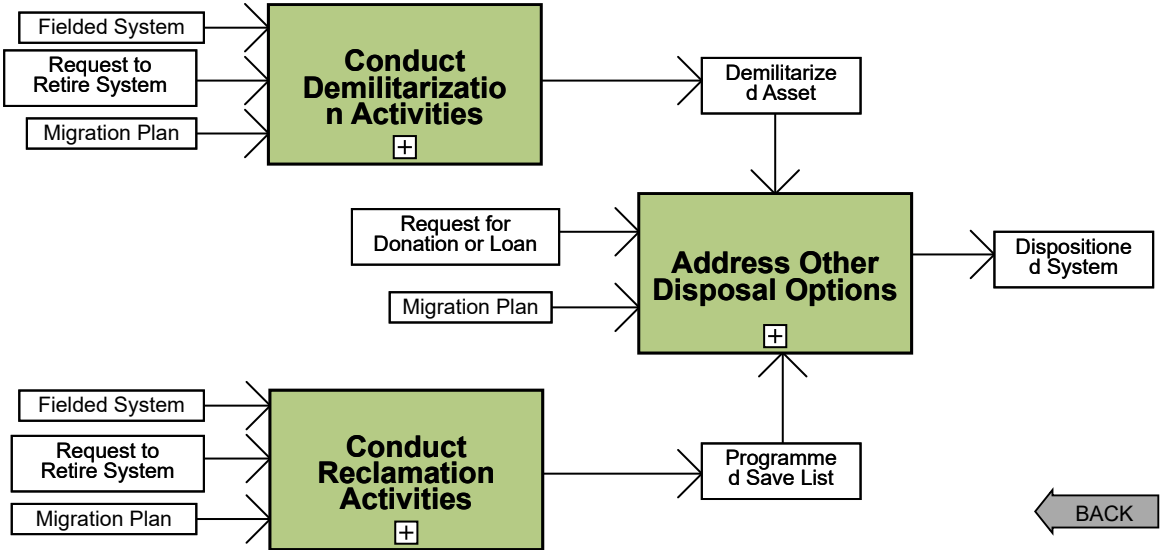

BACK

Go Up 1 Level

Acquisition Process Model

1.4.3.4.1 Conduct Demilitarization Activities

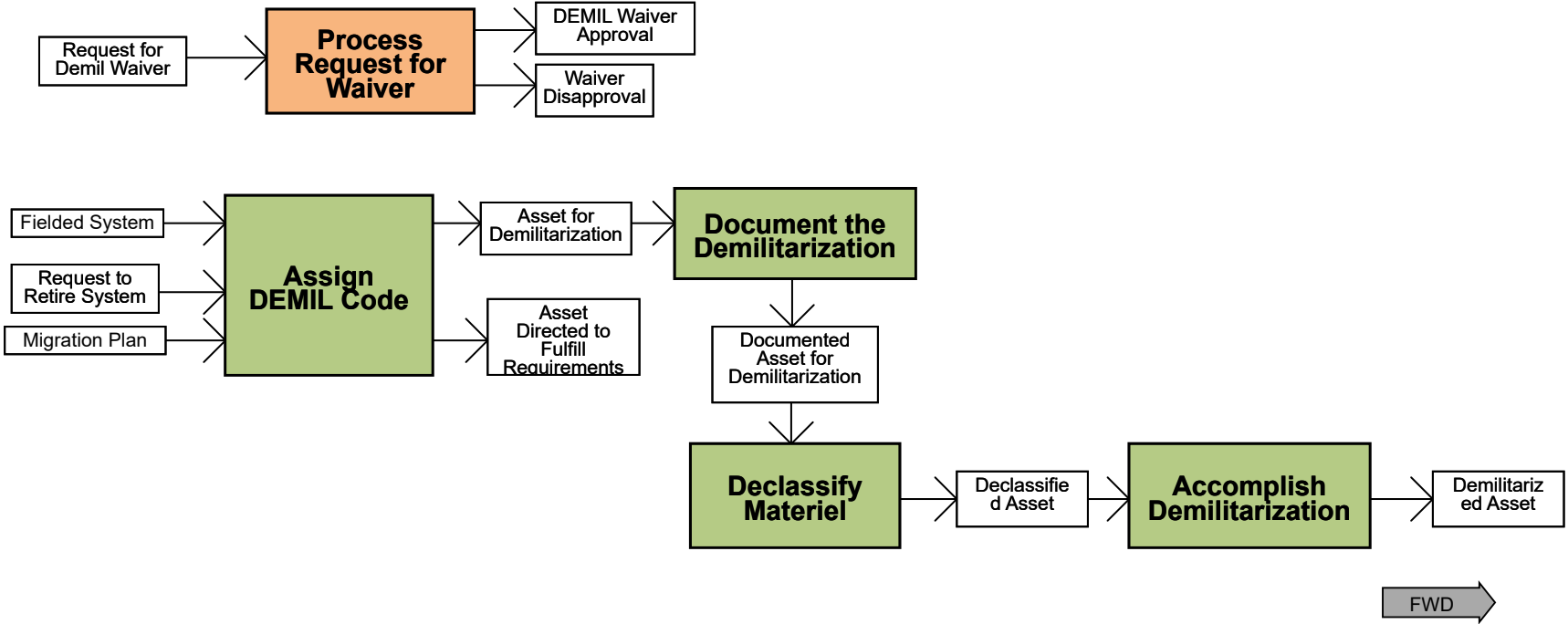

Go Up 1 Level

Acquisition Process Model

1.4.3.4.2 Conduct Reclamation Activities

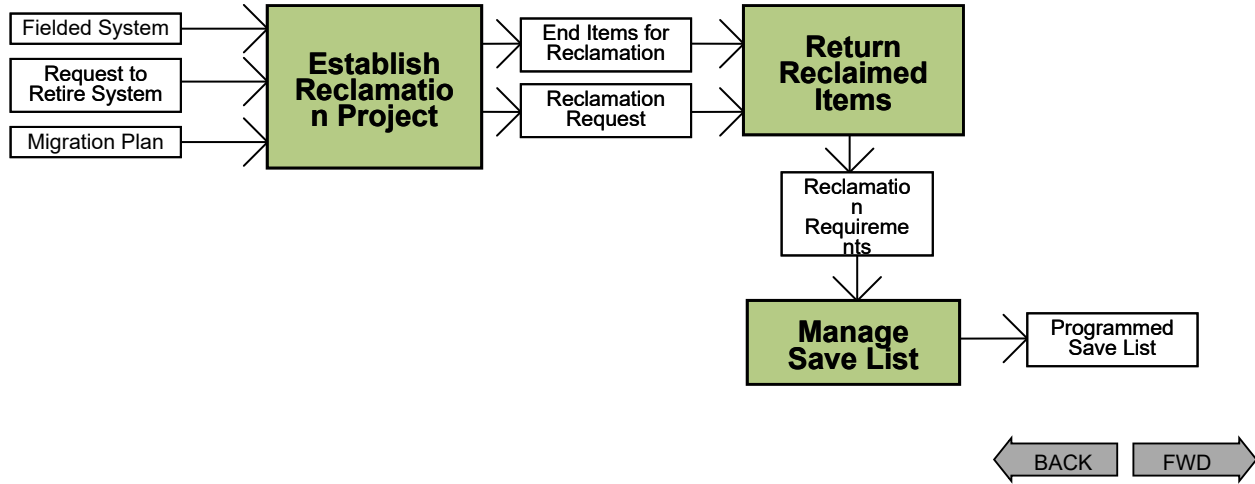

Go Up 1 Level

Acquisition Process Model

1.4.3.4.3 Address Other Disposal Options

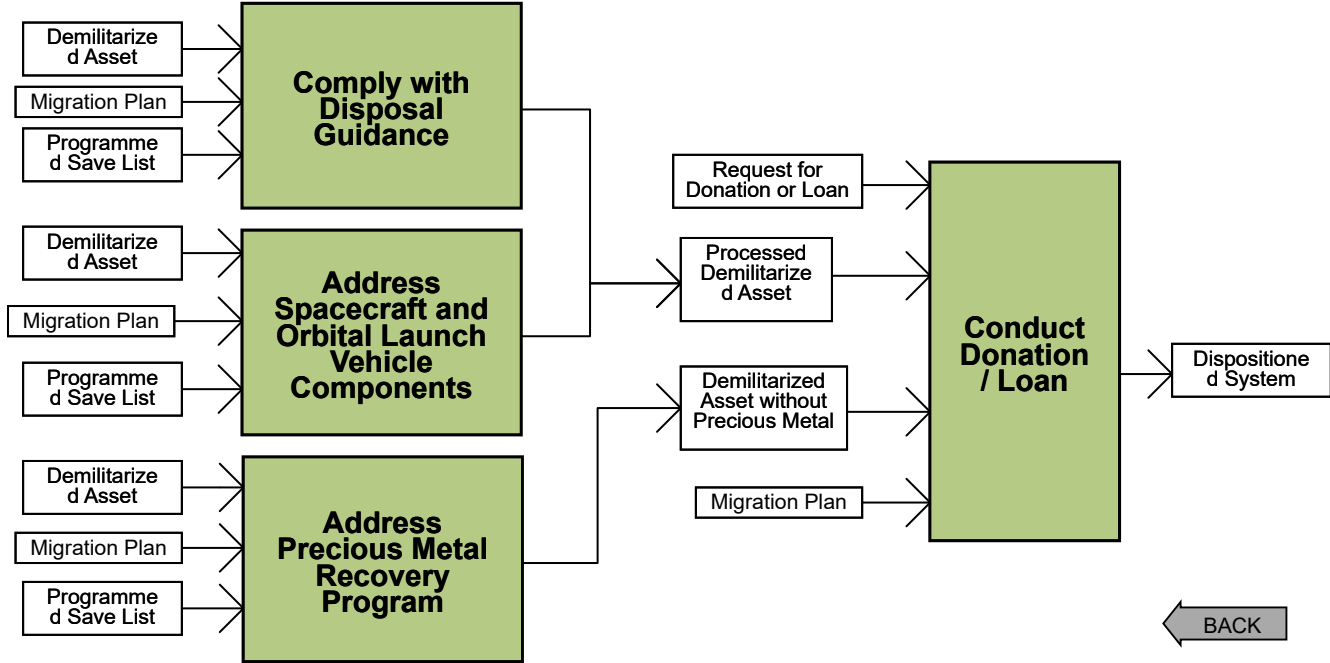

Go Up 1 Level

Acquisition Process Model

1.4.4 Contract Management

AFLCMC Standard Processes

PEO View

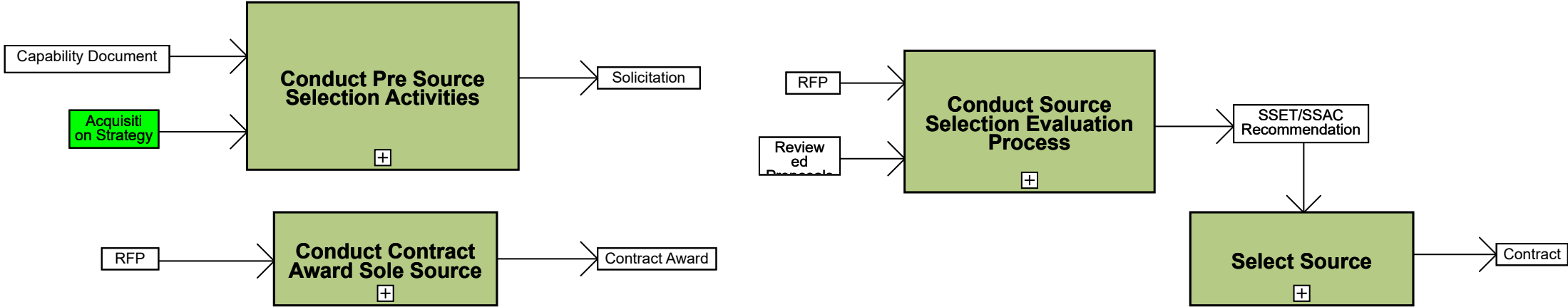

Note 1: Click to access an Active Link to Mr. Kendall's 21 Aug 2014 Memo on Actions to Improve DoD Competition. The guidelines he mentions in the memo are also available as an Active Link.

Note 2: The Conduct Contract Award Sole Source process is an AFLCMC Standard Process

← BACK

FWD →

Go Up 1 Level

Acquisition Process Model

1.4.4.1 Conduct Pre Source Selection Activities

AFLCMC Standard Processes

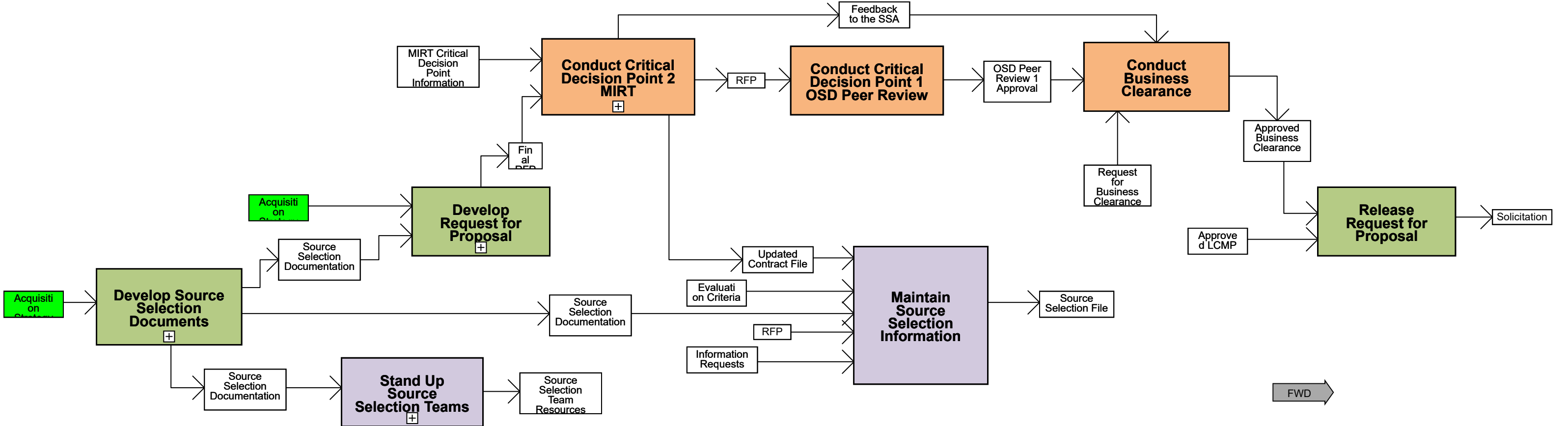

Note 1: An AFLCMC specific process exists to describe the RFP Process. This AFLCMC process is contained within the Air Force Process depicted here. Click here to access an active link to this process.

Note 2: For information regarding Small Business Solicitation Package and Source Selection Team click the link below:
SB 1.3 RFP Generation

FWD

Go Up 1 Level

Acquisition Process Model

1.4.4.1.1 Develop Source Selection Documents

AFLCMC
Standard
Processes

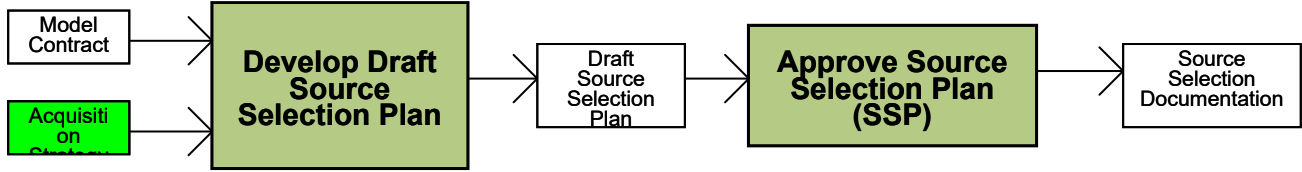

Note: An AFLCMC specific process exists to describe the RFP Process. This AFLCMC process is contained within the Air Force Process depicted here. Click here to access an active link to this process.

FWD

Go Up 1 Level

Acquisition Process Model

1.4.4.1.2 Develop Request for Proposal

AFLCMC Standard Processes

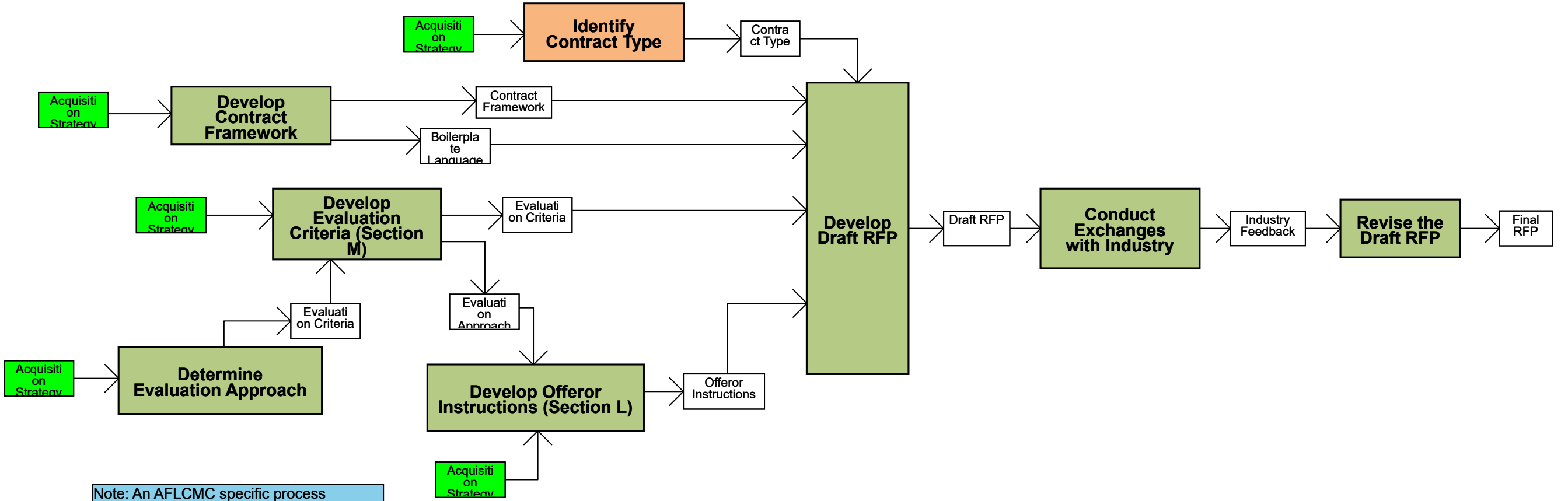

Note: An AFLCMC specific process exists to describe the RFP Process. This AFLCMC process is contained within the Air Force Process depicted here. Click here to access an active link to this process.

BACK FWD

Go Up 1 Level

Acquisition Process Model

1.4.4.1.3 CDP 2 (RFP Sections L and M) MIRT

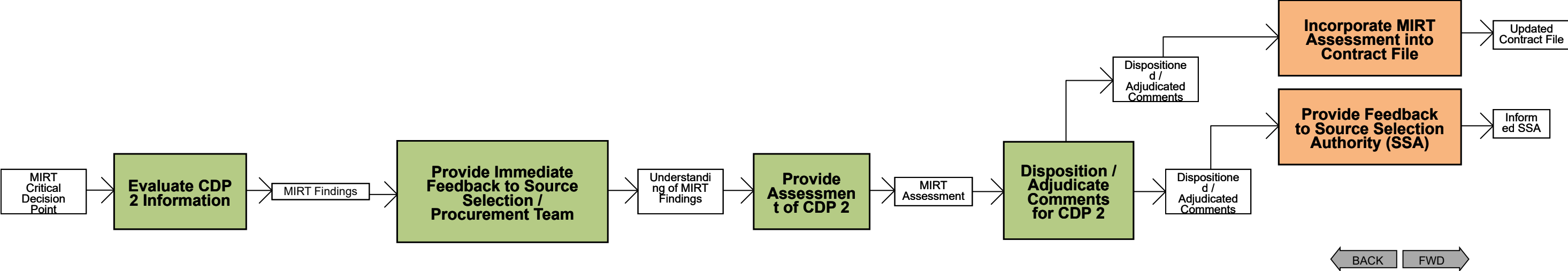

Note: For information regarding Small Business MIRT click the link below:
SB. 1.6 Post Award/Stand Alone Processes

Go Up 1 Level

Acquisition Process Model

1.4.4.1.4 Stand Up Source Selection Teams

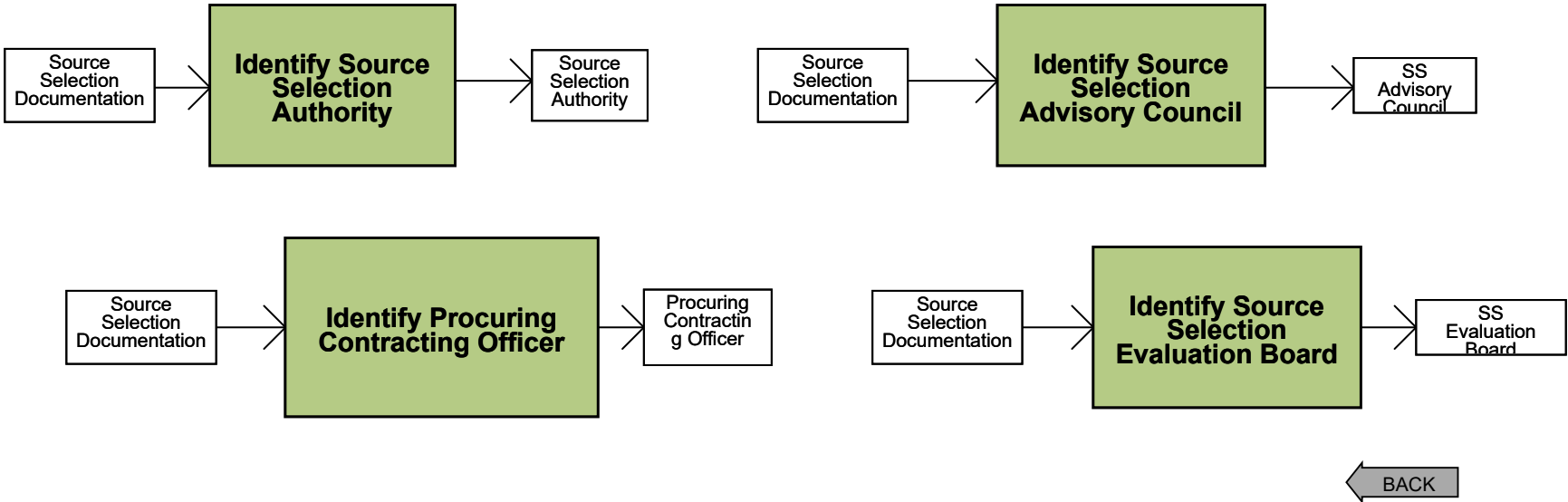

Go Up 1 Level

Acquisition Process Model

1.4.4.2 Conduct Source Selection Evaluation Process

AFLCMC Standard Processes

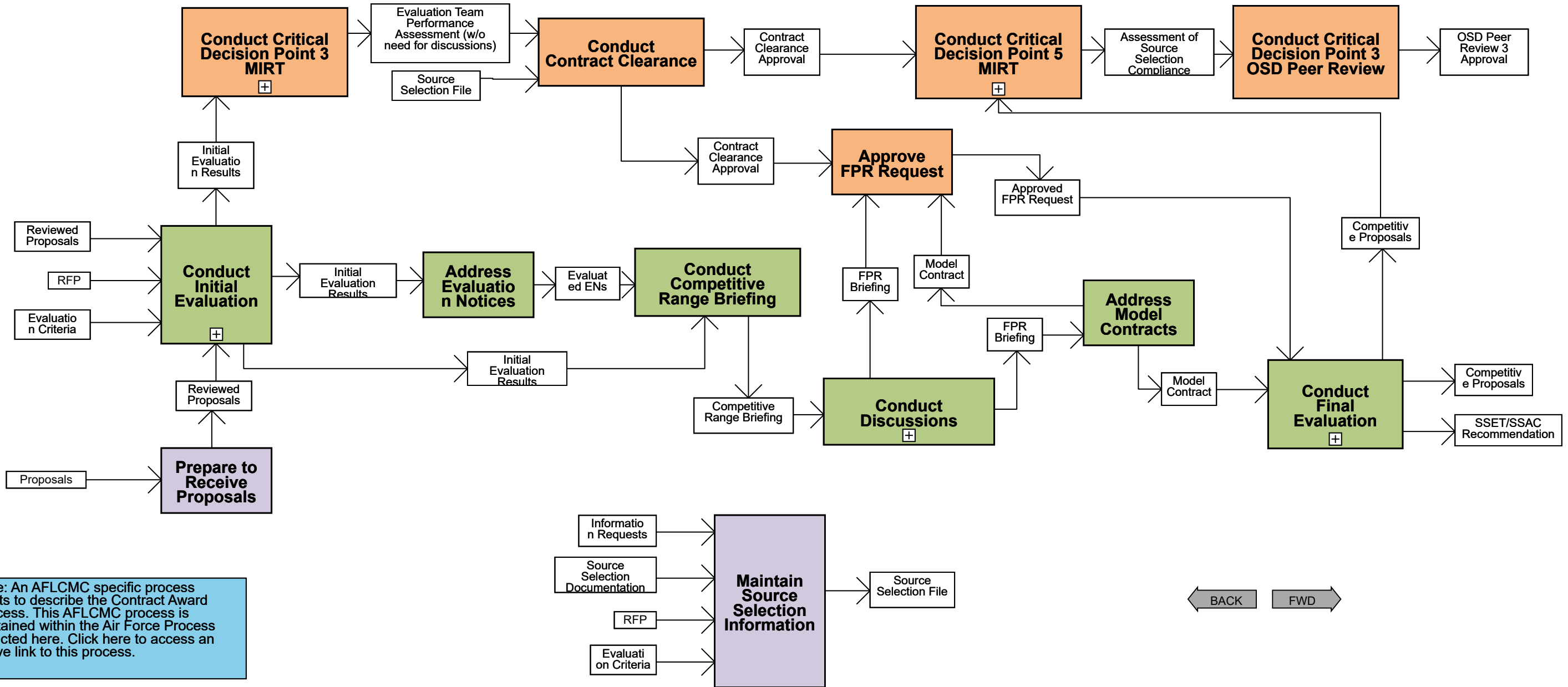

Note: An AFLCMC specific process exists to describe the Contract Award Process. This AFLCMC process is contained within the Air Force Process depicted here. Click here to access an active link to this process.

Go Up 1 Level

Acquisition Process Model

1.4.4.2.1 Conduct Initial Evaluation

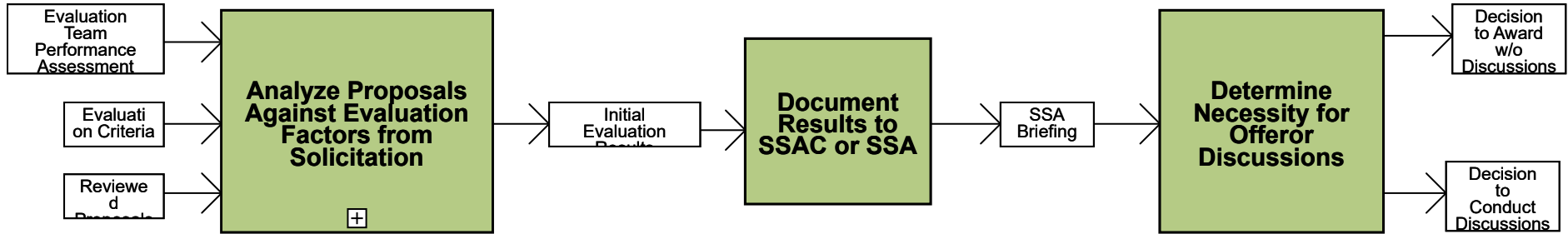

FWD

Note: For information regarding Small Business MIRT Click the link below:
SB. 1.6 Post Award/Stand Alone Processes

Acquisition Process Model

1.4.4.2.1.1 Analyze Proposals Against Evaluation Factors from Solicitation

Go Up 1 Level

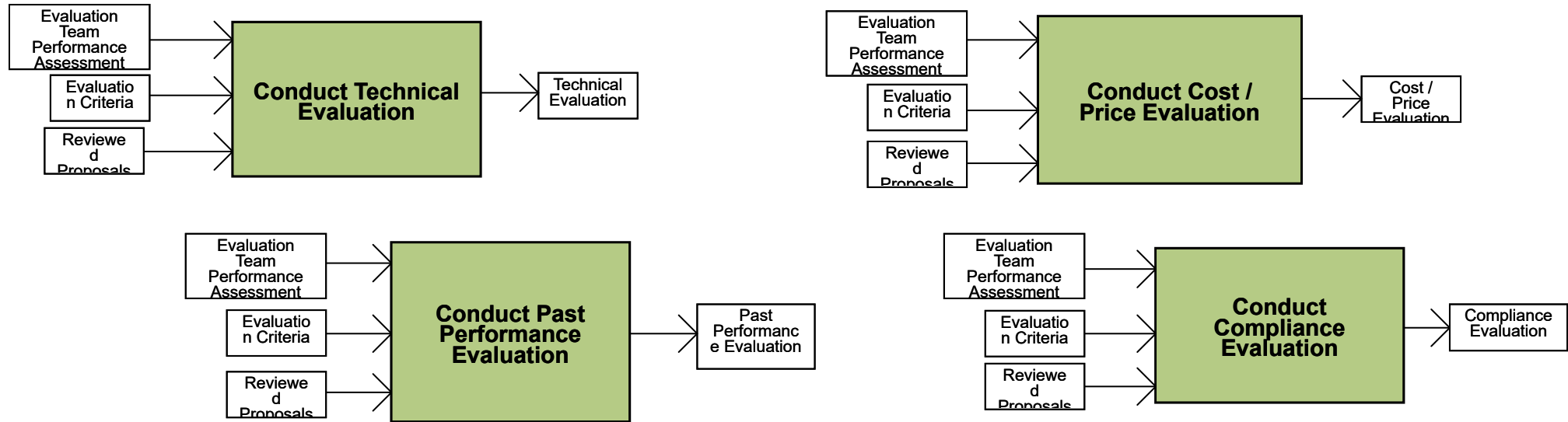

Go Up 1 Level

Acquisition Process Model

1.4.4.2.2 Conduct CDP 3 (Pre-Initial Evaluation/Pre-Competitive Range (Award w/o Discussions)/Pre-release of Interim Ratings) MIRT

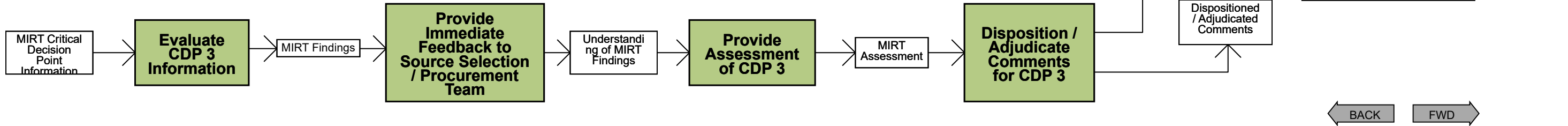

Go Up 1 Level

Acquisition Process Model

1.4.4.2.5 Conduct Discussions

AFLCMC Standard Processes

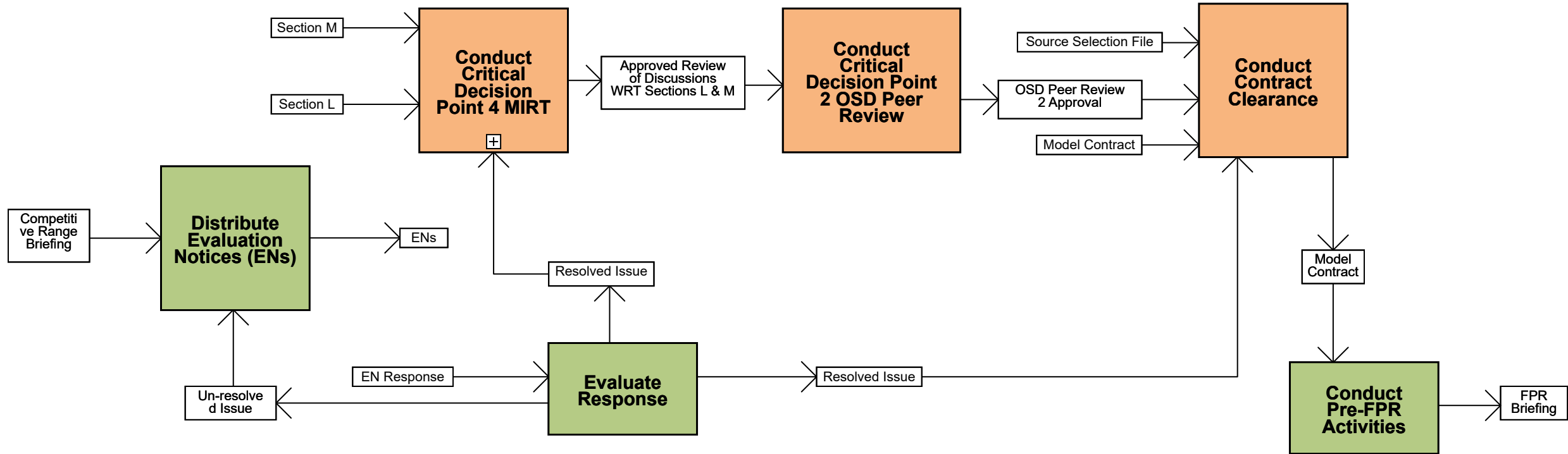

Note: An AFLCMC specific process exists to describe the Contract Award Process. This AFLCMC process is contained within the Air Force Process depicted here. Click here to access an active link to this process.

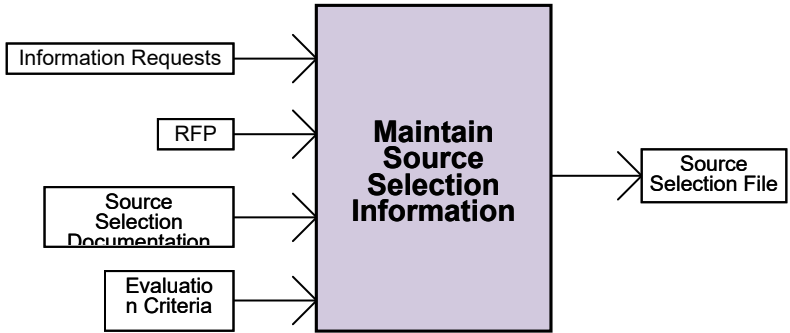

BACK FWD

Go Up 1 Level

Acquisition Process Model

1.4.4.2.5.3 Conduct CDP 4 (Pre-Final Proposal Decision Brief) MIRT

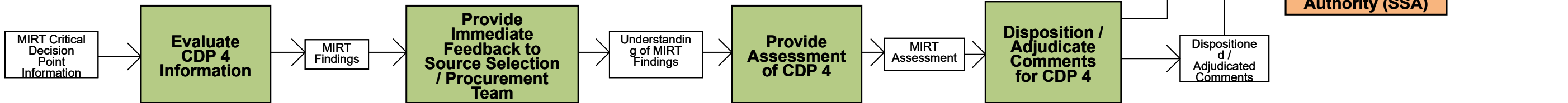

Acquisition Process Model

1.4.4.2.6 Conduct Final Evaluation

Go Up 1 Level

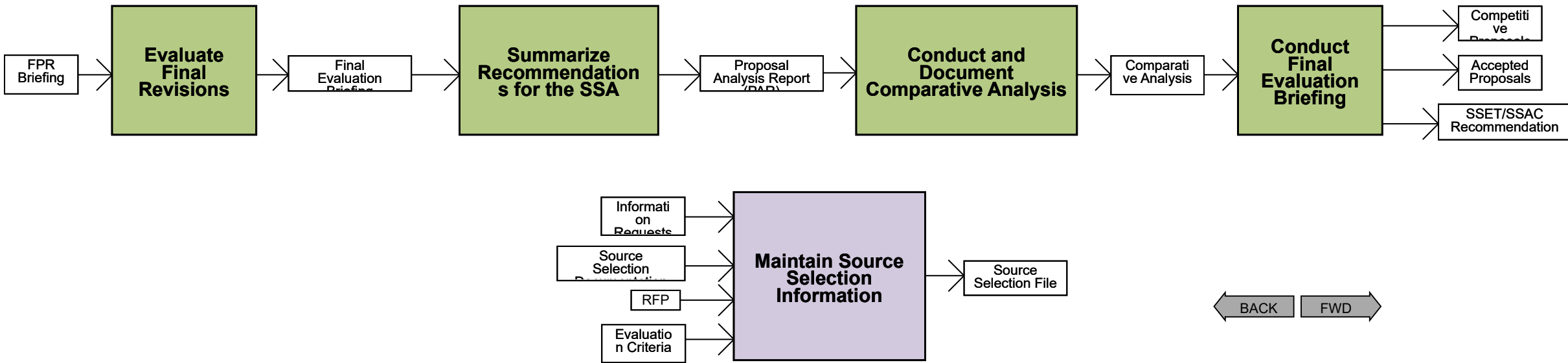

Go Up 1 Level

Acquisition Process Model

1.4.4.2.7 Conduct CDP 5 (Pre-Source Selection Decision Brief) MIRT

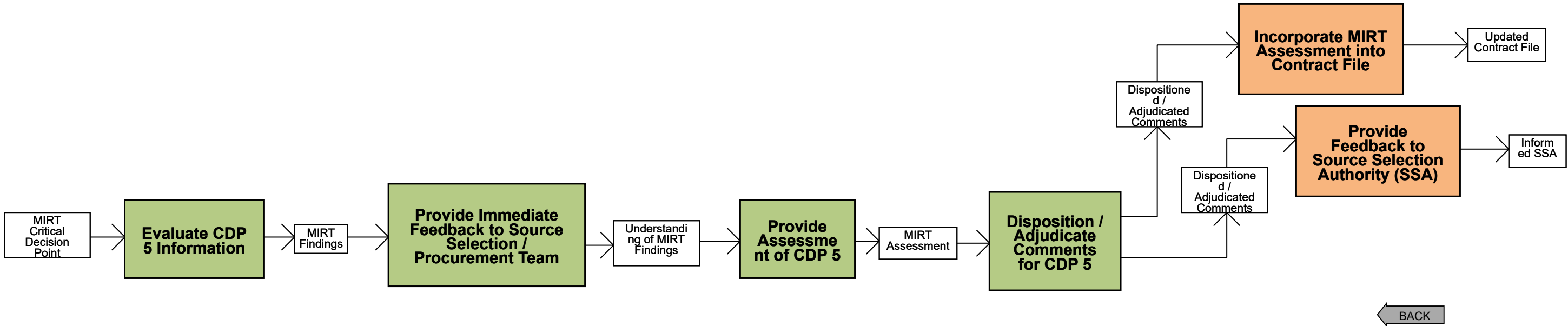

Note: For information regarding Small Business MIRT Click the link below:
SB. 1.6 Post Award/Stand Alone Processes

Acquisition Process Model

1.4.4.3 Select Source

Go Up 1 Level

AFLCMC
Standard
Processes

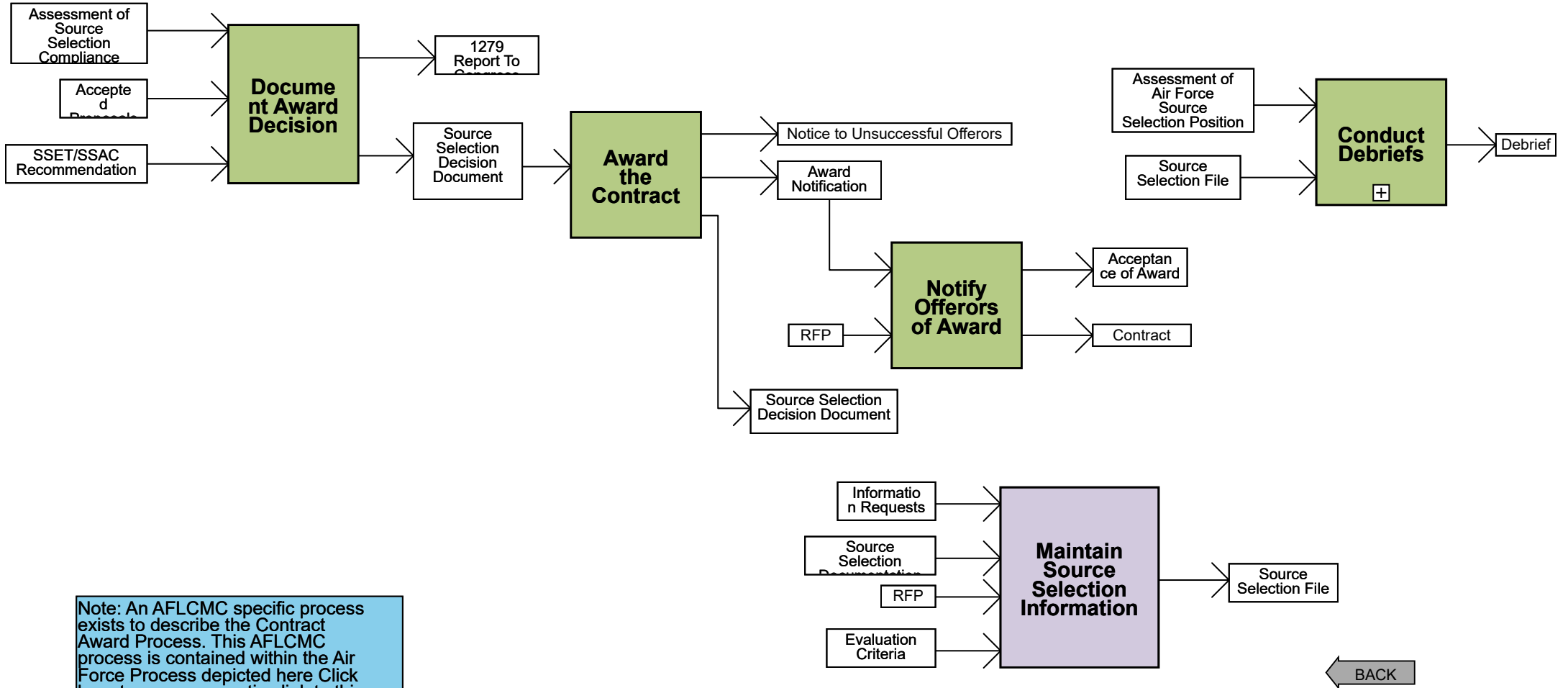

Note: An AFLCMC specific process exists to describe the Contract Award Process. This AFLCMC process is contained within the Air Force Process depicted here. Click here to access an active link to this process.

BACK

Go Up 1 Level

Acquisition Process Model

1.4.4.3.5 Conduct Debriefs

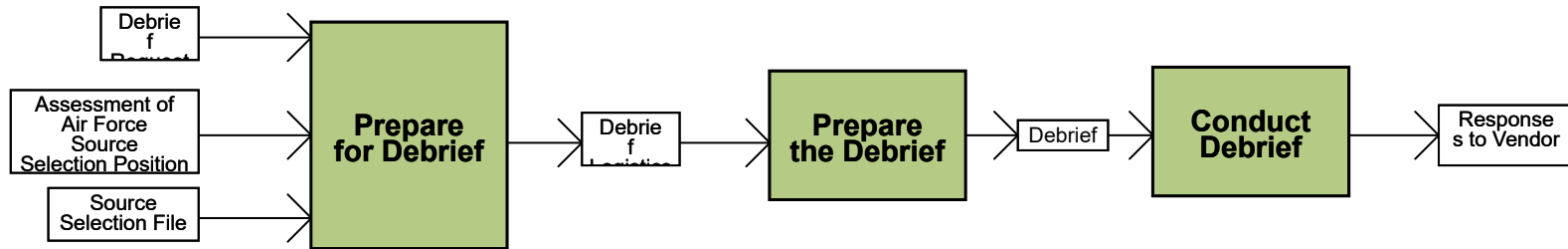

Acquisition Process Model

1.4.4.4 Conduct Contract Award Sole Source

Go Up 1 Level

AFLCMC
Standard
Processes

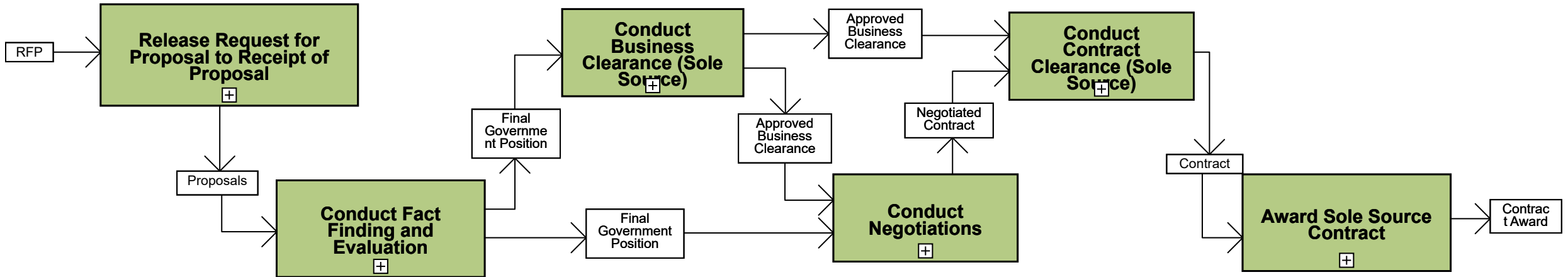

NOTE: The DoD Sole Source Streamlining Toolbox is a living document encompassing over 40 techniques which can be leveraged to increase efficiency throughout the acquisition process. Click here to access the toolkit.

Acquisition Process Model

1.4.4.4.1 Release Request for Proposal to Receipt of Proposal

Go Up 1 Level

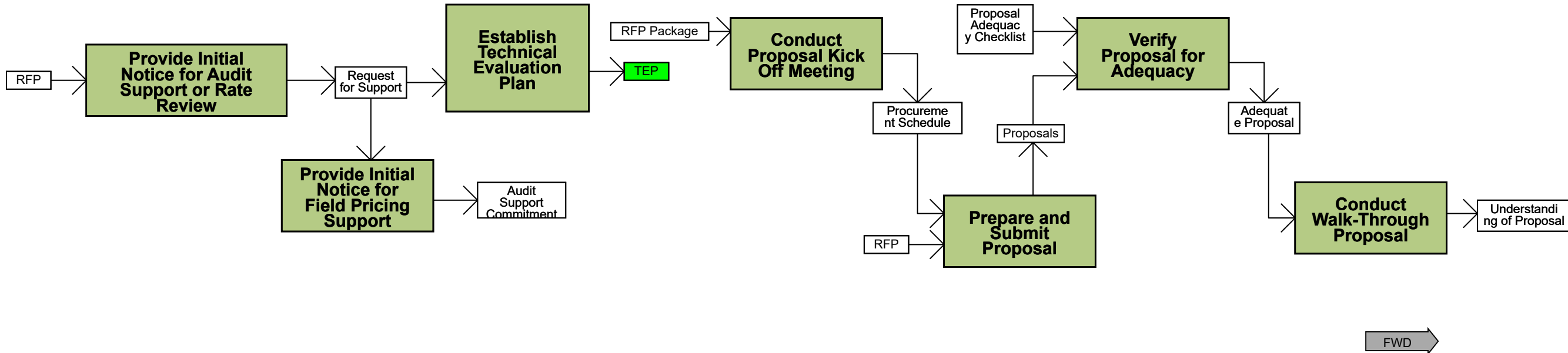

Go Up 1 Level

Acquisition Process Model

1.4.4.2 Conduct Fact Finding and Evaluation

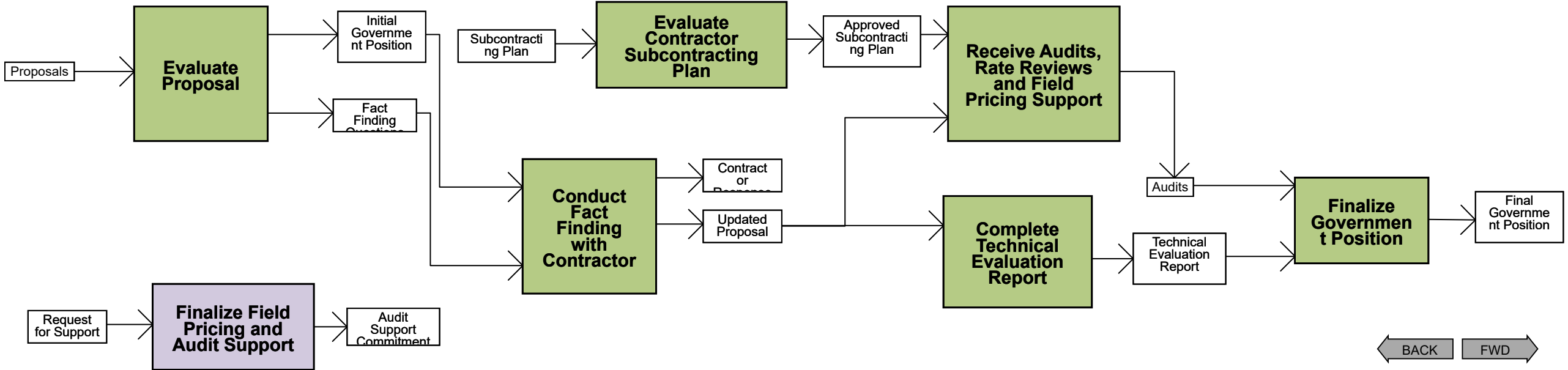

Note: For information regarding Small Business Subcontracting click the link below:
SB. 1.4 Evaluation and Award

Acquisition Process Model

1.4.4.4.3 Conduct Business Clearance

Go Up 1 Level

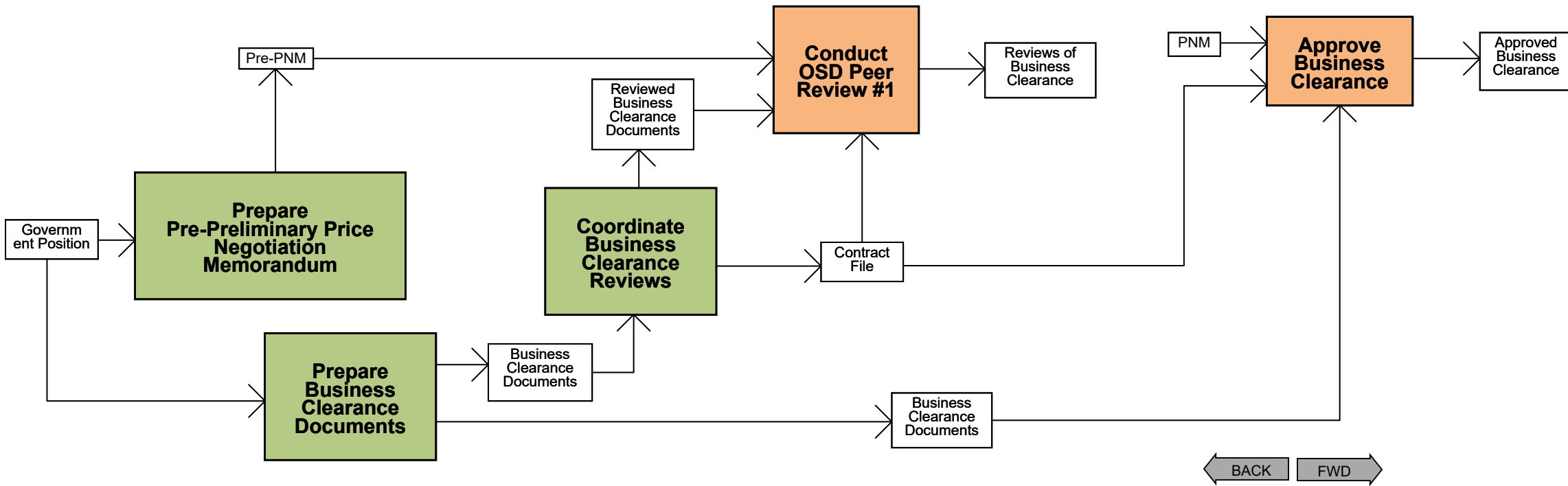

Go Up 1 Level

Acquisition Process Model

1.4.4.4 Conduct Negotiations

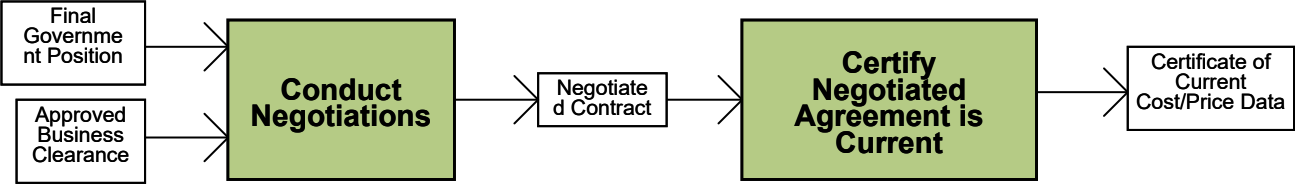

← BACK

FWD →

Go Up 1 Level

Acquisition Process Model

1.4.4.4.5 Conduct Contract Clearance

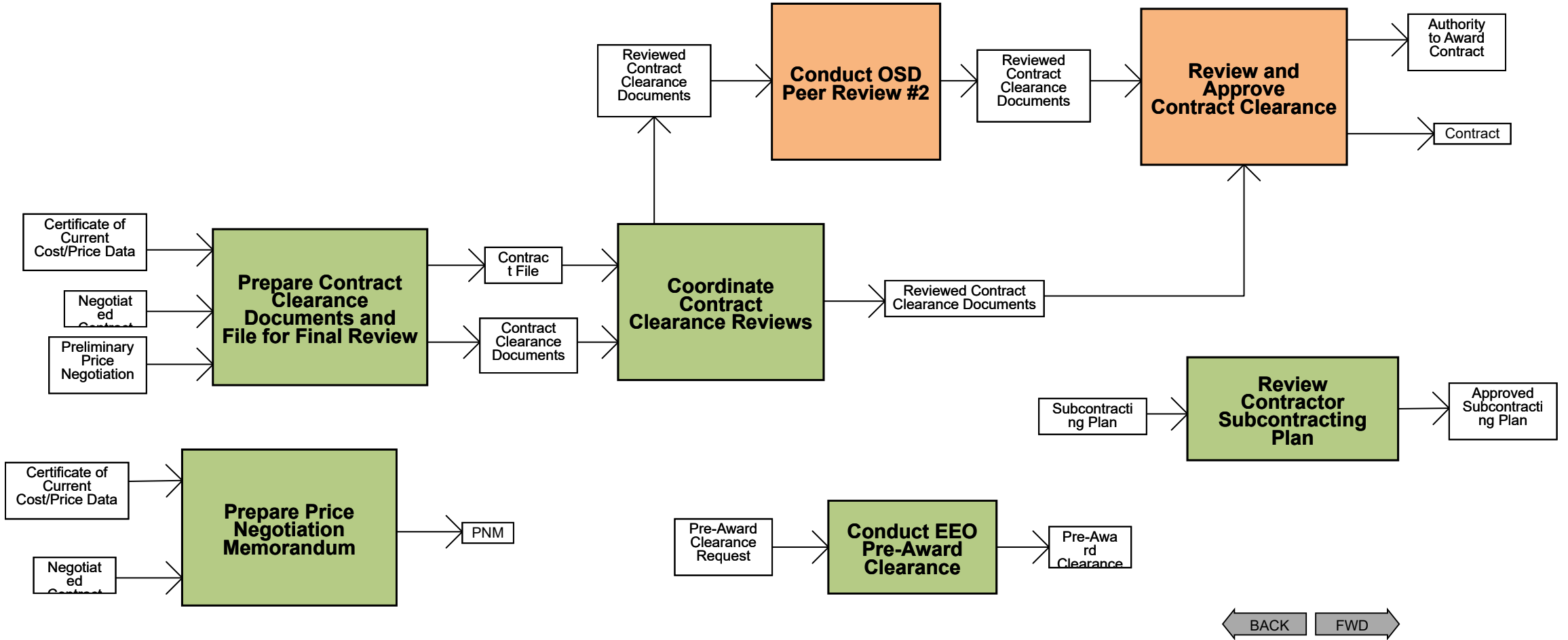

Go Up 1 Level

Acquisition Process Model

1.4.4.4.6 Award Sole Source Contract

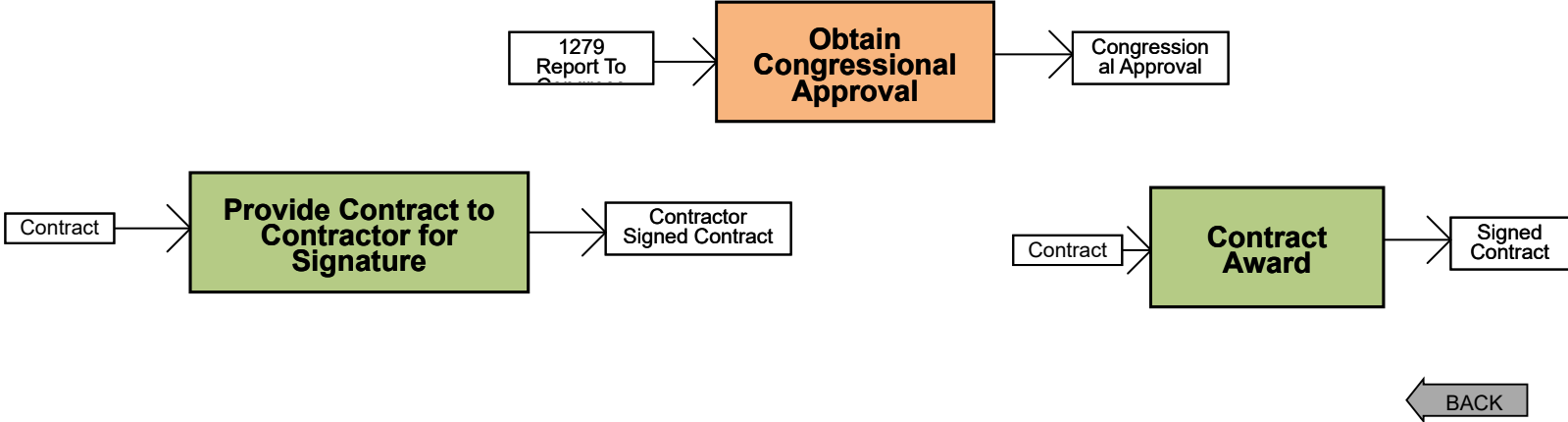

Go Up 1 Level

Acquisition Process Model

1.4.5 Test & Evaluation

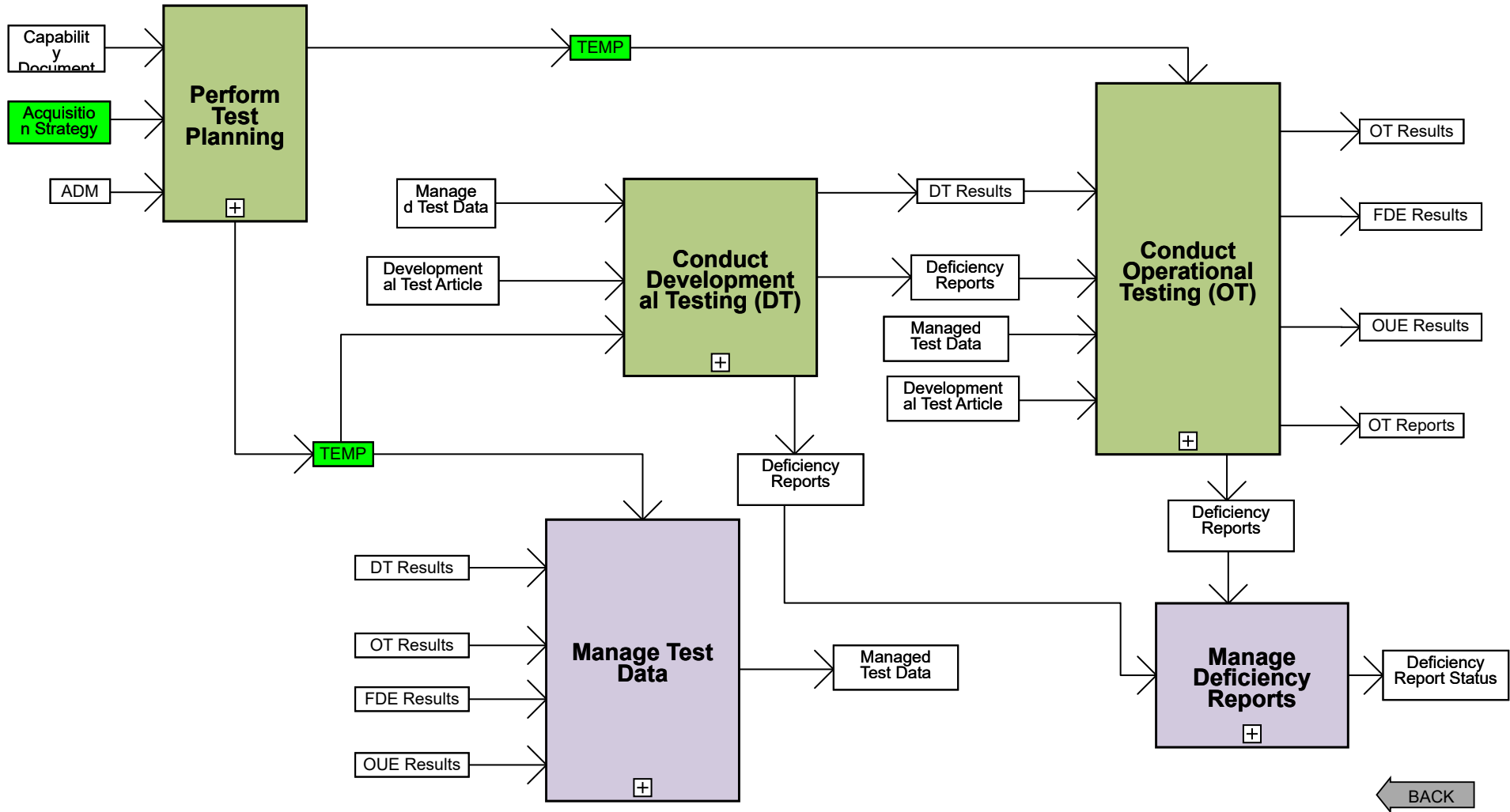

Acquisition Process Model

1.4.5.1 Perform Test Planning

Go Up 1 Level

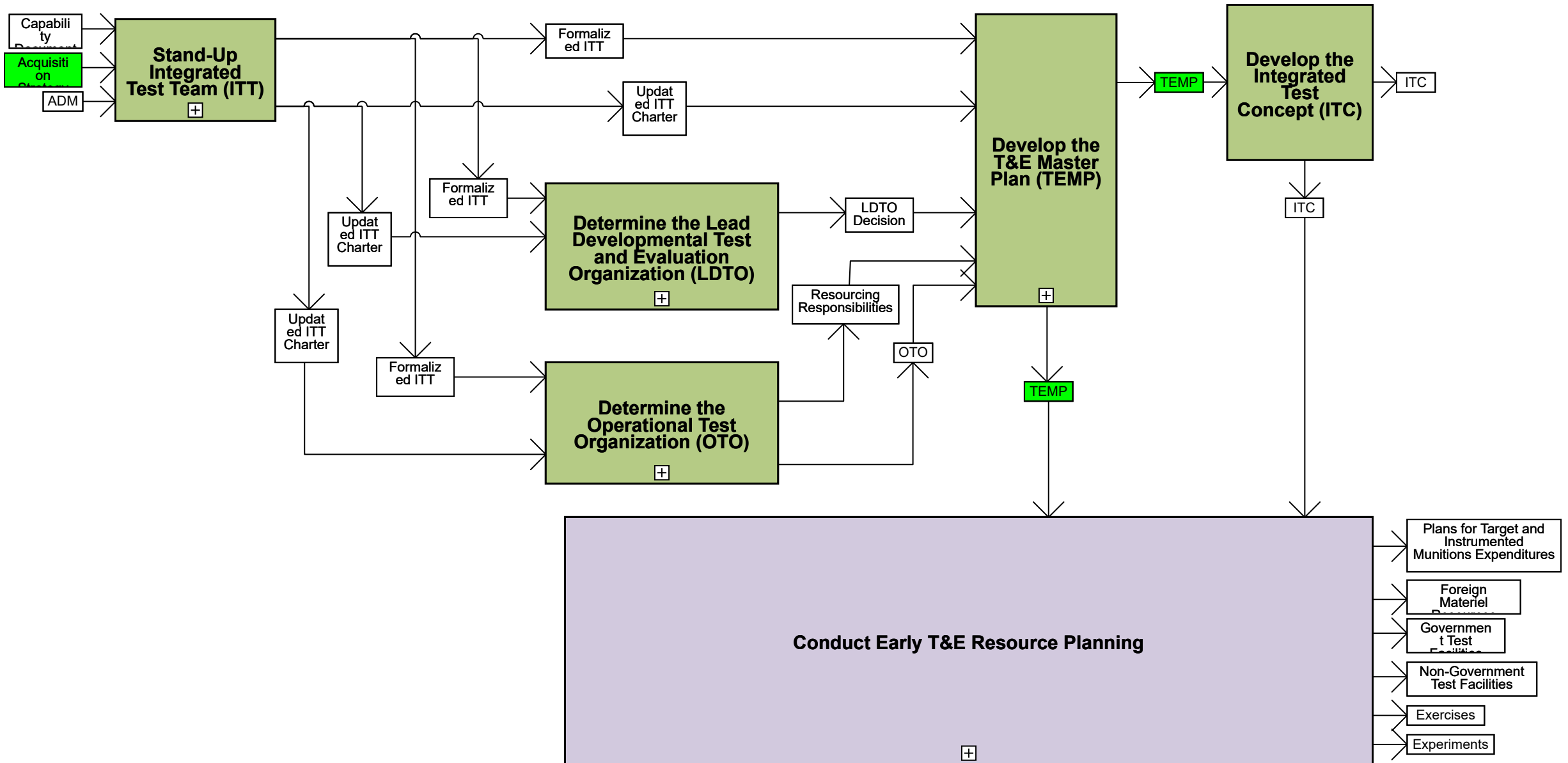

FWD

Acquisition Process Model

1.4.5.1.1 Stand-Up Integrated Test Team (ITT)

Go Up 1 Level

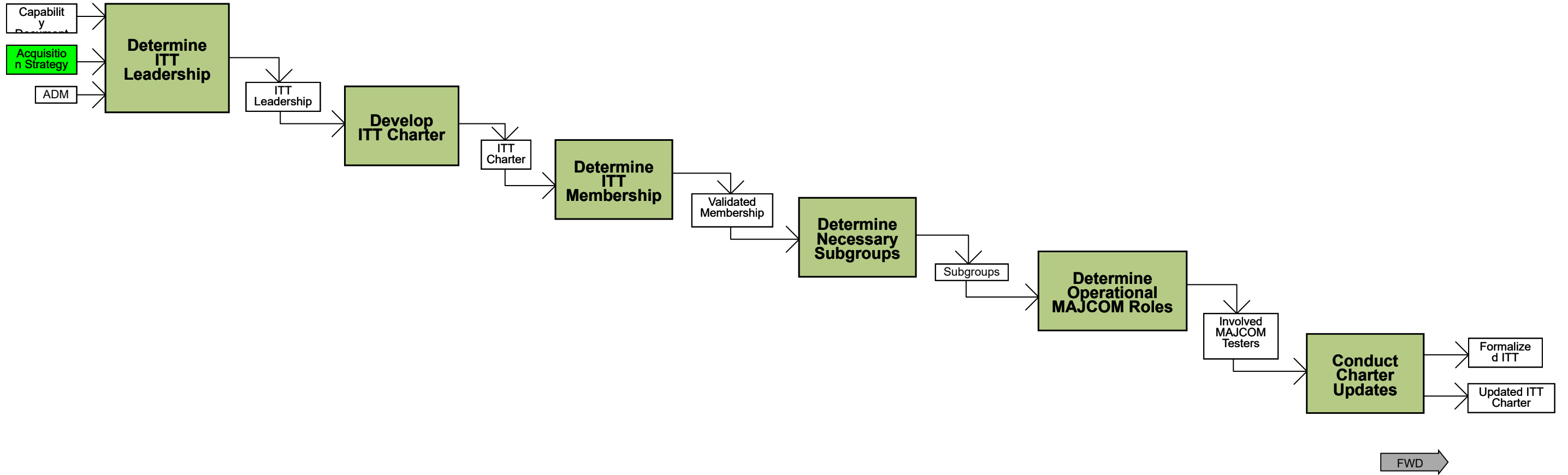

Go Up 1 Level

Acquisition Process Model

1.4.5.1.2 Determine the Lead Developmental Test and Evaluation Organization (LDTO)

AFLCMC Standard Processes

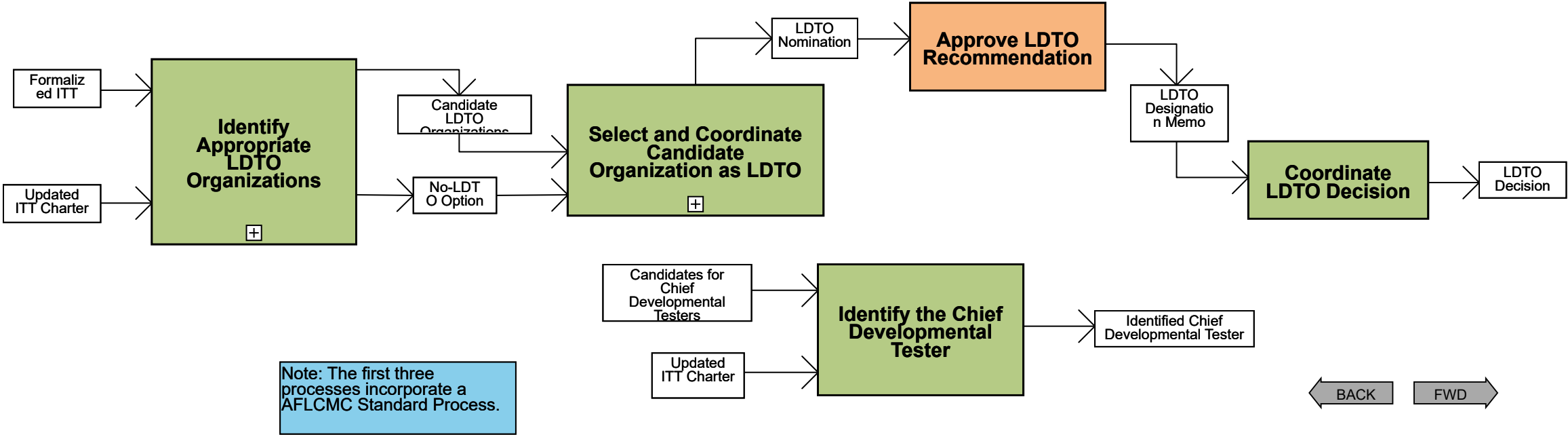

Note: The first three processes incorporate a AFLCMC Standard Process.

BACK

FWD

Go Up 1 Level

Acquisition Process Model

1.4.5.1.2.1 Identify Appropriate LDTO Organizations

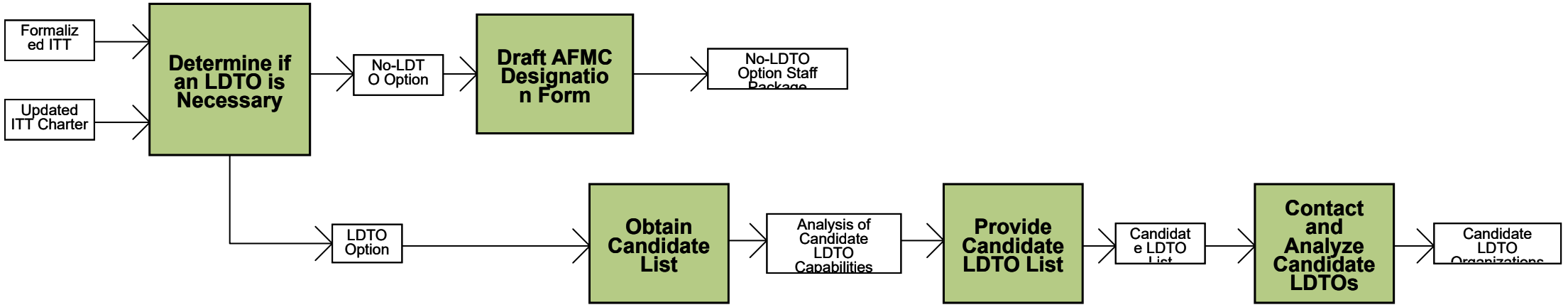

Note: The above process is part of an AFLCMC Standard Process.

FWD

Go Up 1 Level

Acquisition Process Model

1.4.5.1.2.2 Select and Coordinate Candidate Organization as LDTO

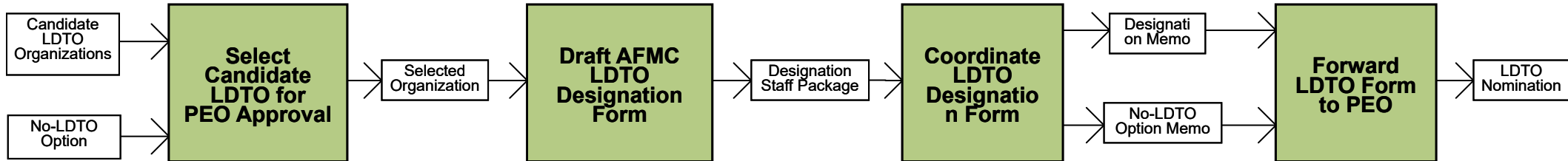

Note: The above process is part of an AFLCMC Standard Process.

← BACK

Go Up 1 Level

Acquisition Process Model

1.4.5.1.3 Determine the Operational Test Organization (OTO)

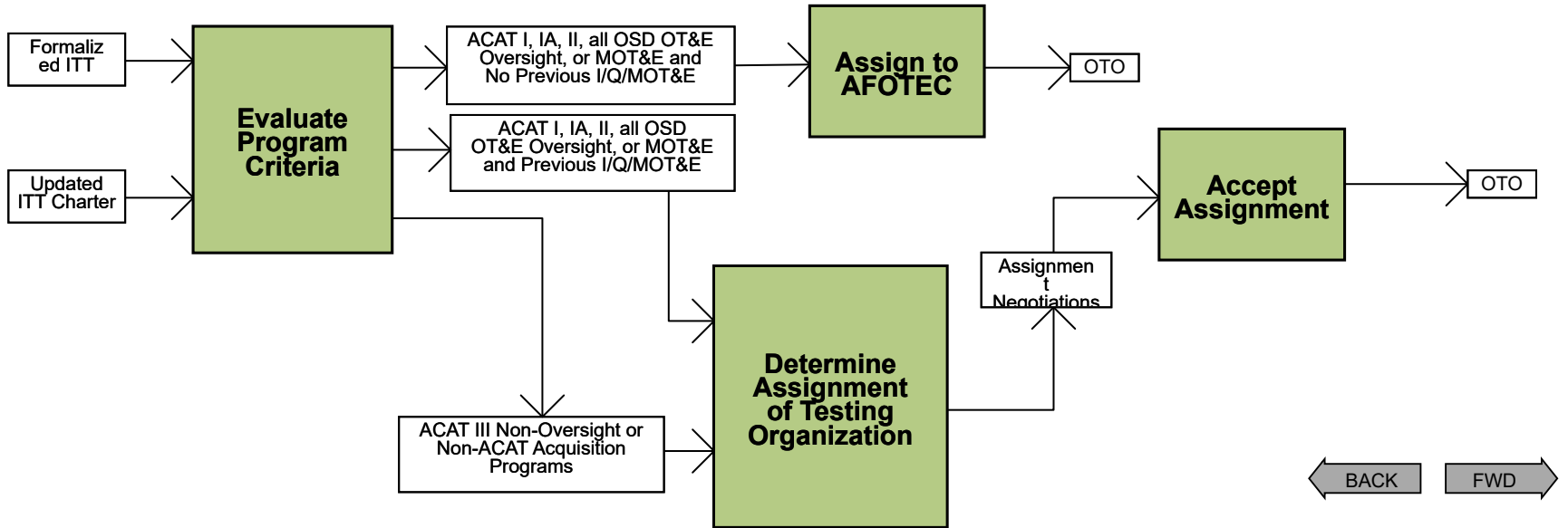

Go Up 1 Level

Acquisition Process Model

1.4.5.1.5 Develop the TEMP

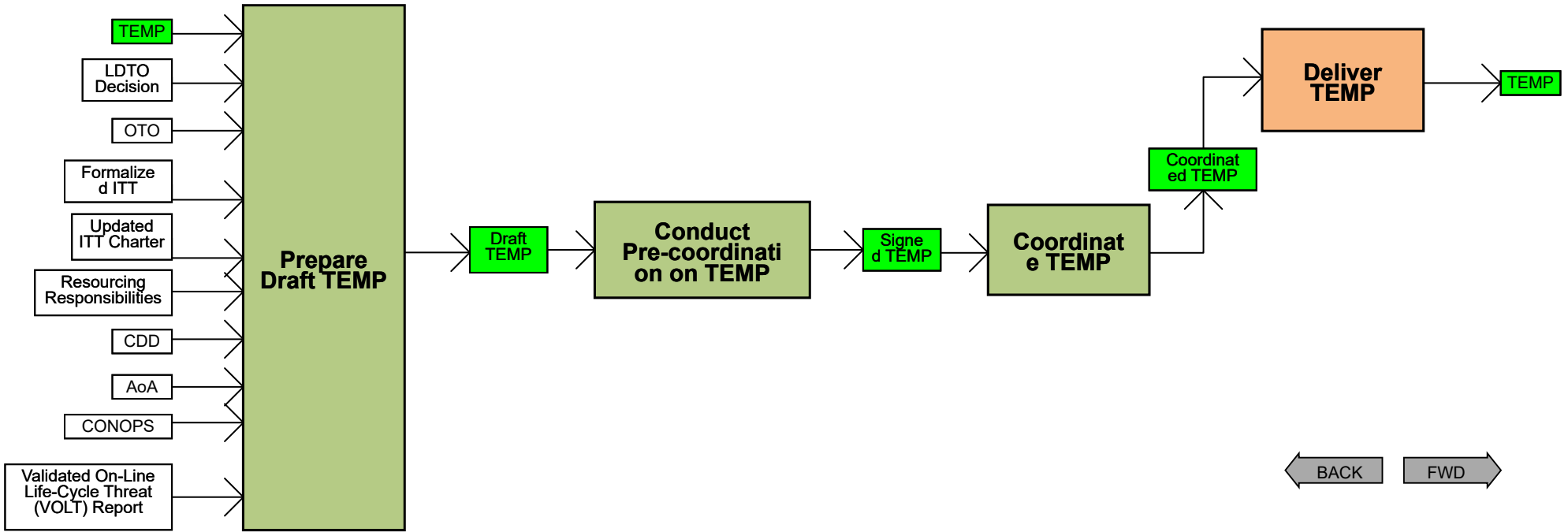

Go Up 1 Level

Acquisition Process Model

1.4.5.1.7 Conduct Early T&E Resource Planning

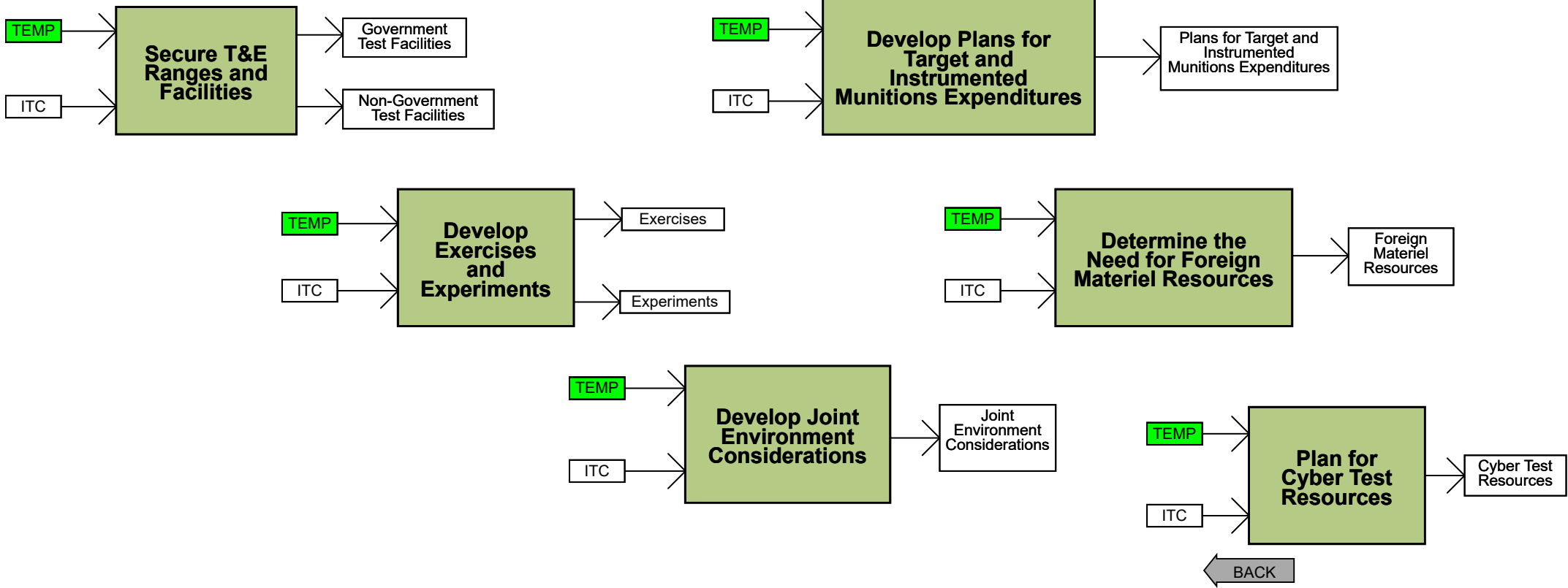

Go Up 1 Level

Acquisition Process Model

1.4.5.2 Conduct Developmental Testing

PEO View

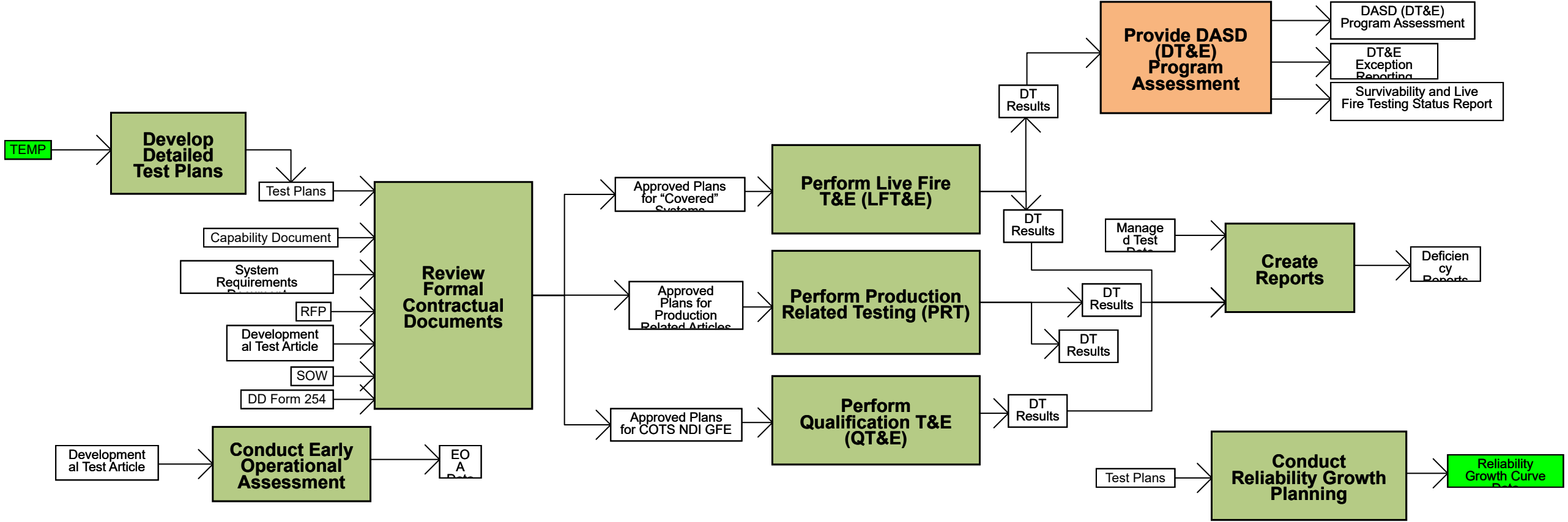

Note 1: Testing of Urgent Needs is included in the 1.3.3.2.3 process.

Note 2: Consistent with Section 5.14 of AFI 99-103, all aspects of cyber test including required resources, manpower, and infrastructure must be planned for and documented in the TEMP.

← BACK FWD →

Acquisition Process Model

1.4.5.3 Conduct Operational Testing

PEO View

Go Up 1 Level

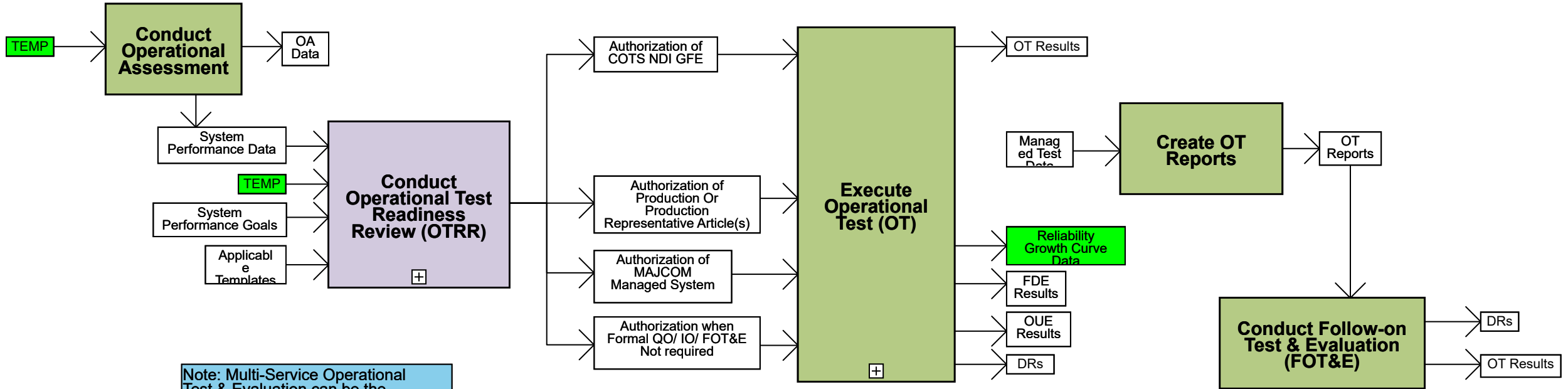

Note: Multi-Service Operational Test & Evaluation can be the FOT&E process provided above when conducted by two or more Services.

Acquisition Process Model

1.4.5.3.1 Conduct Operational Test Readiness Review (OTRR)

Go Up 1 Level

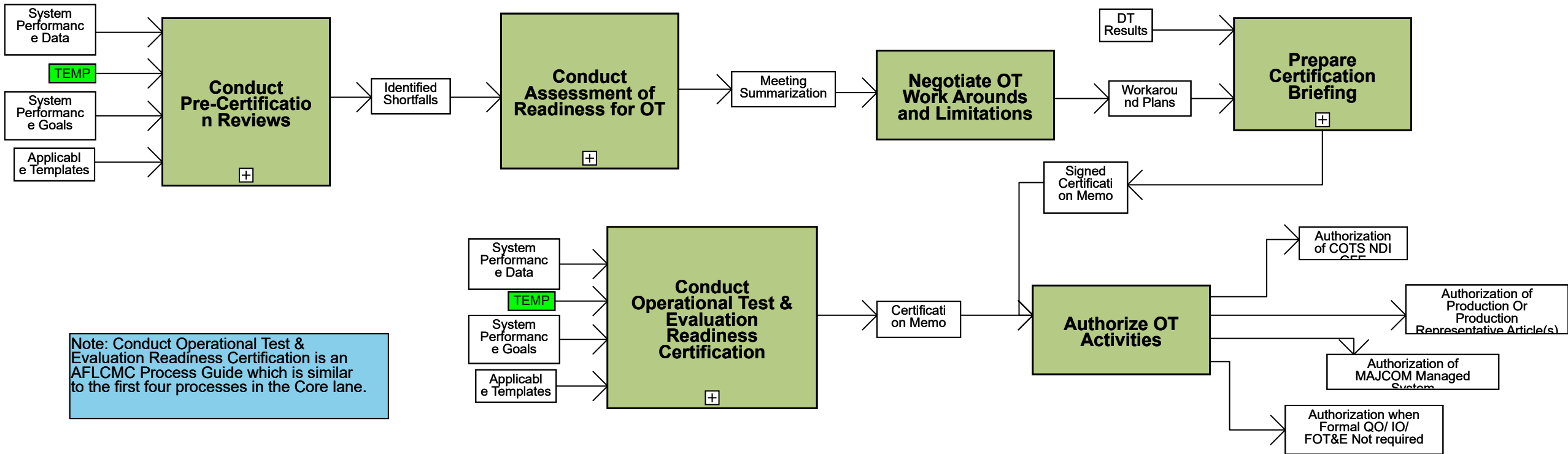

Note: Conduct Operational Test & Evaluation Readiness Certification is an AFLCMC Process Guide which is similar to the first four processes in the Core lane.

FWD

Go Up 1 Level

Acquisition Process Model

1.4.5.3.1.1 Conduct Pre-Certification Process

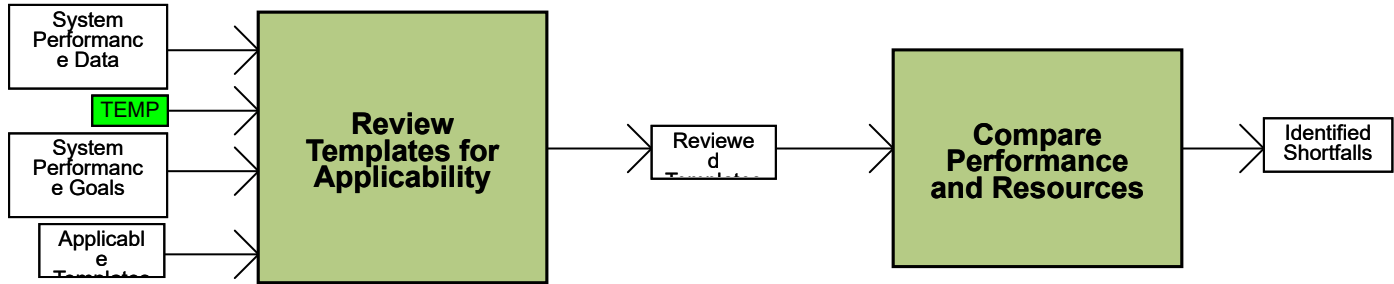

FWD

Acquisition Process Model

1.4.5.3.1.2 Conduct Assessment of Readiness for OT

Go Up 1 Level

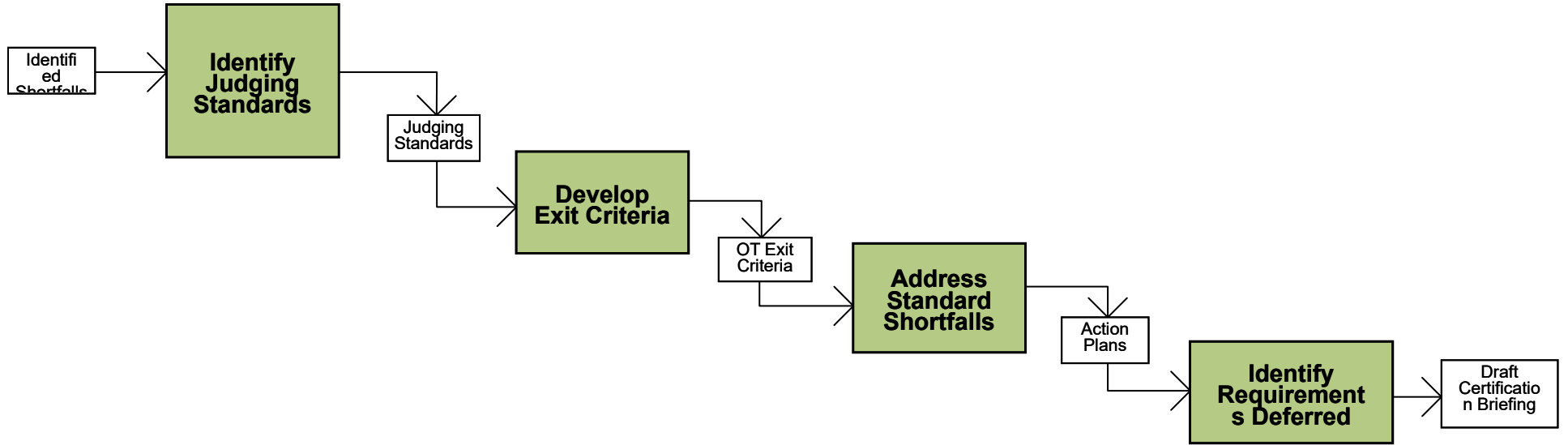

BACK

FWD

Go Up 1 Level

Acquisition Process Model

1.4.5.3.1.4 Prepare Certification Briefing

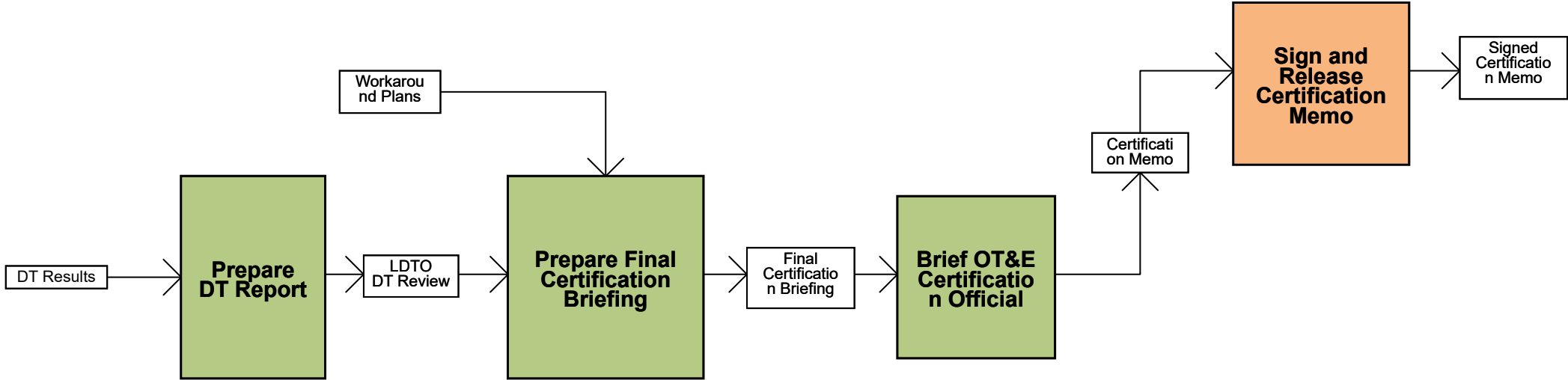

← BACK

FWD →

Go Up 1 Level

Acquisition Process Model

1.4.5.3.1.5 Conduct Operational Test & Evaluation Readiness Certification

AFLCMC Standard Processes

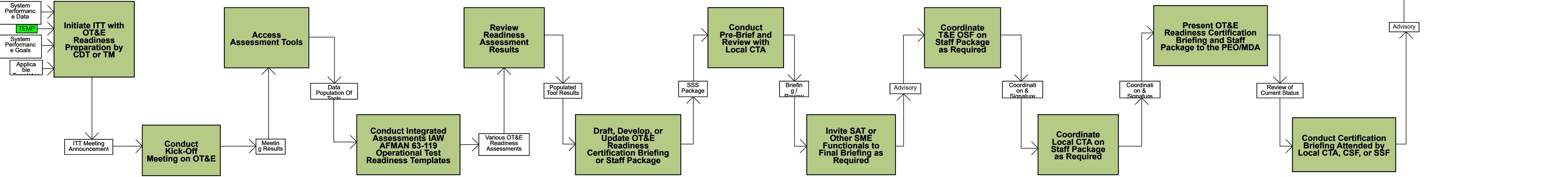

Note: Incorporated references to the AFLCMC Process Guide (OT&E Readiness Certification).

BACK

Go Up 1 Level

Acquisition Process Model

1.4.5.3.2 Execute Operational Testing

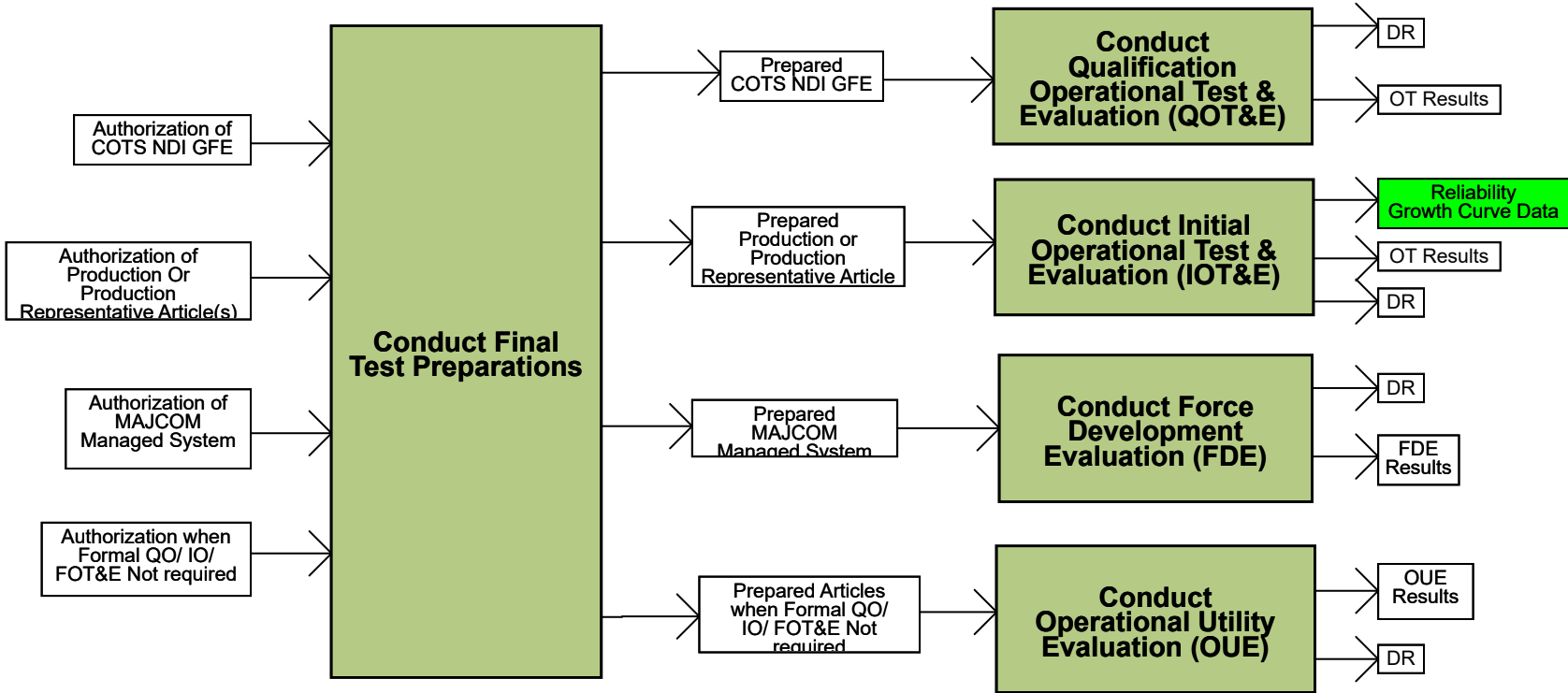

Note: Multi-Service Operational Test & Evaluation is OT&E (IOT&E, QOT&E, FOT&E, or FDE) conducted by two or more Service OTOs for systems acquired by more than one Service.

← BACK

Go Up 1 Level

Acquisition Process Model

1.4.5.4 Manage Test Data

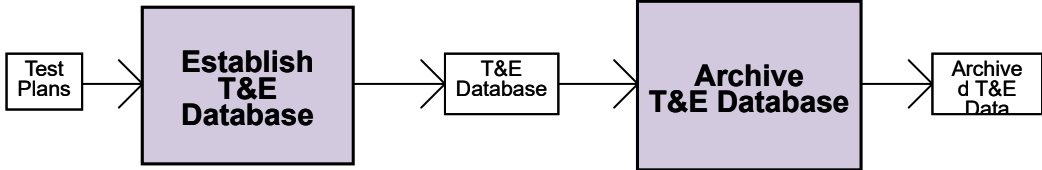
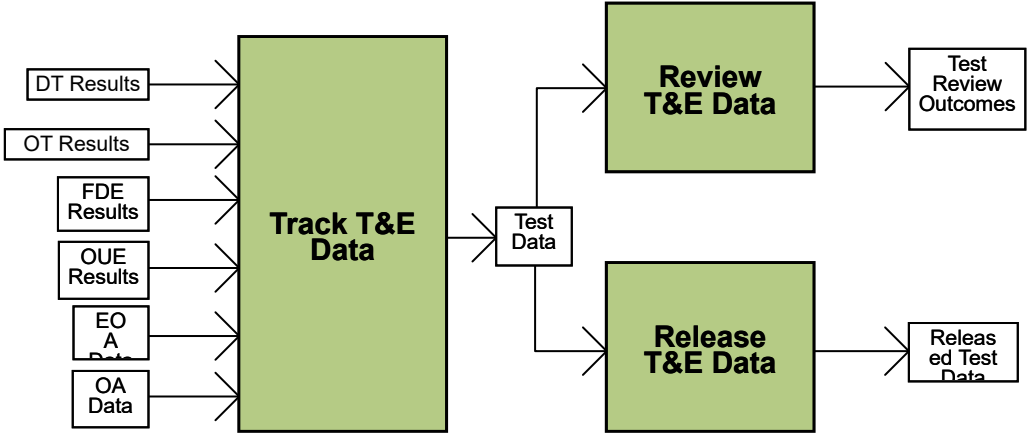

Note: The bottom processes interact with all of the top processes.

← BACK

FWD →

Go Up 1 Level

Acquisition Process Model

1.4.5.5 Manage Deficiency Reports

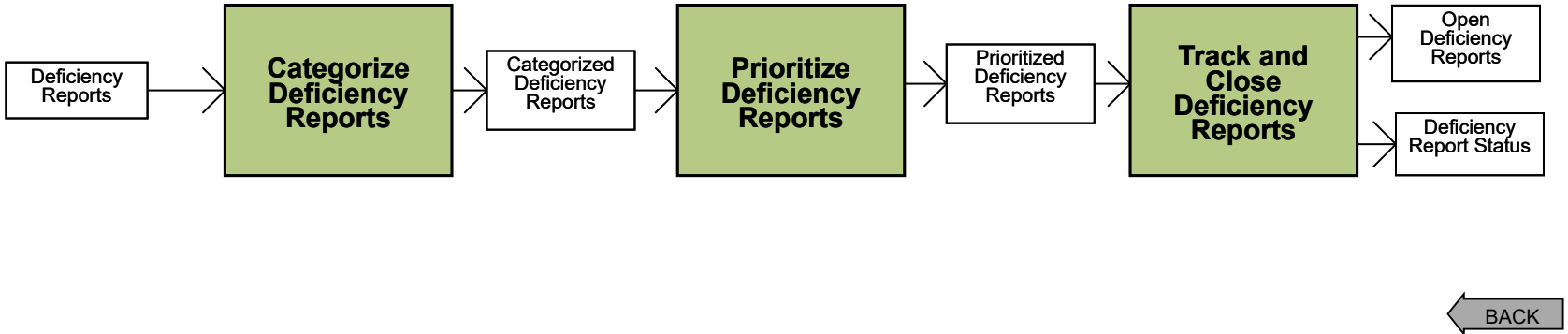

← BACK

Go Up 1 Level

Acquisition Process Model

1.5 Conduct "Program" Management Tasks

Note 1 from the Chief Process Officer: The Under Secretary of Defense for AT&L has provided four key enduring acquisition principles. The first of these principles is "Think". Program managers should tailor the program according to the specific needs of that program. The rote checking the blocks in a checklist or simply following each and every step of a process is the antithesis of Mr Kendall's challenge to Program Managers. Use this Model as a model. If your program's situation warrants a waiver from the checklist or process, seek that waiver from your milestone decision authority. Click here to access an active link to Mr. Kendall's thoughts.

Note 2: Issue Management applies resources to address and resolve current problems, while risk management applies resources to mitigate future potential root causes and their consequences

Note 3: Program Integration provides the AF with consistent insightful and synchronized recommendations, improved data reporting and analysis, and maximized utilization of resources. The objective is to strengthen decision-making across AF Acquisition leadership.

Note 4: The purpose of program tailoring is to streamline the acquisition program to the maximum extent possible, consistent with risk, to provide new systems to operational commanders as fast as possible. DoDI 5000.02, Section 5.a.2; AFPAM 63-128, Section 14.1

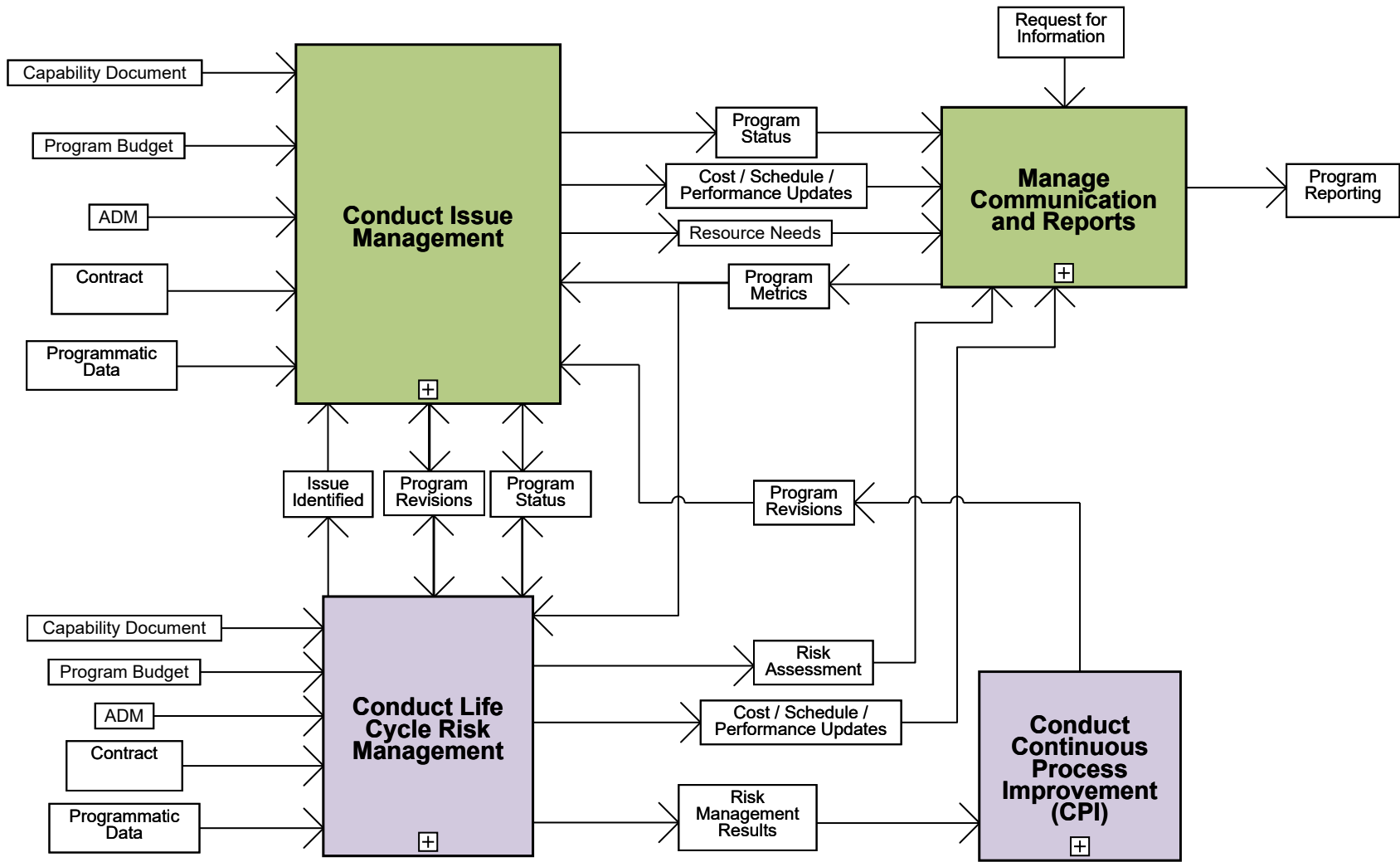

← BACK

Go Up 1 Level

Acquisition Process Model

1.5.1 Conduct Issue Management

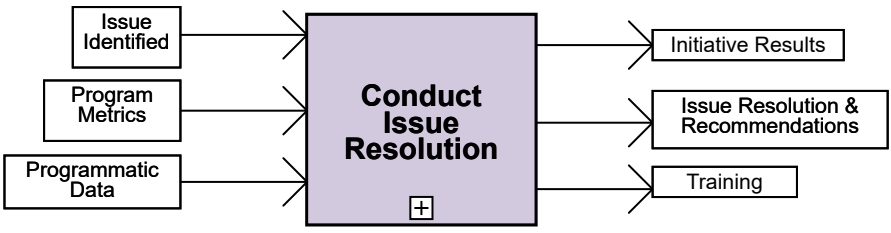
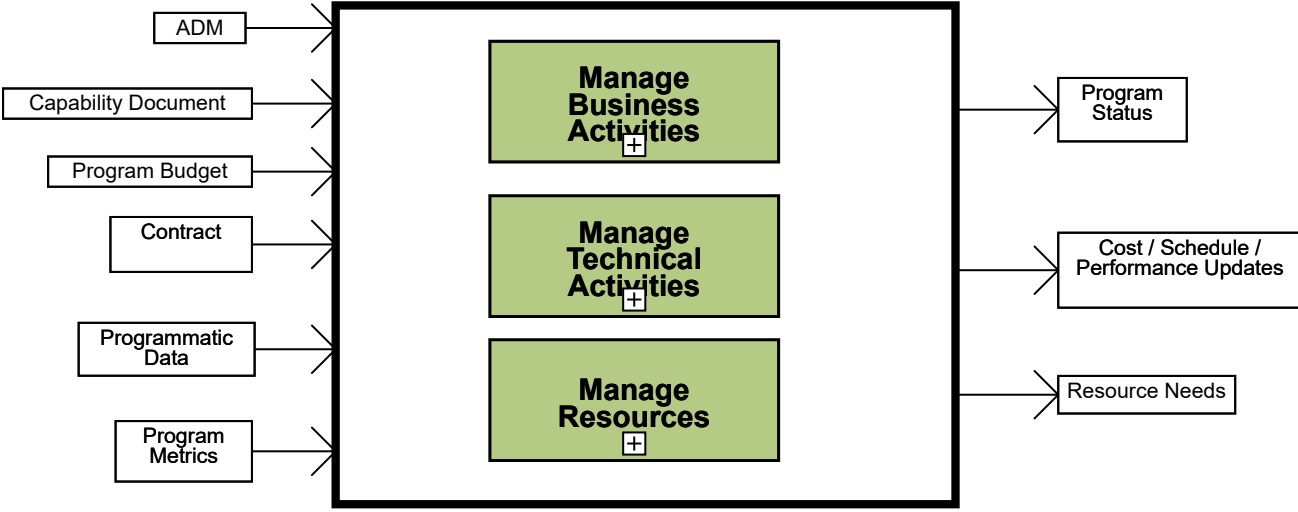

FWD →

Note: The DoD Risk, Issue, and Opportunity Management Guide for Defense Acquisition Programs describes a five-step process for both issue management (Section 3.6) and opportunity management (Section 4), each of which is similar to the Risk Management process. Click to access the guide.

Go Up 1 Level

Acquisition Process Model

1.5.1.1 Manage Business Activities

PEO View

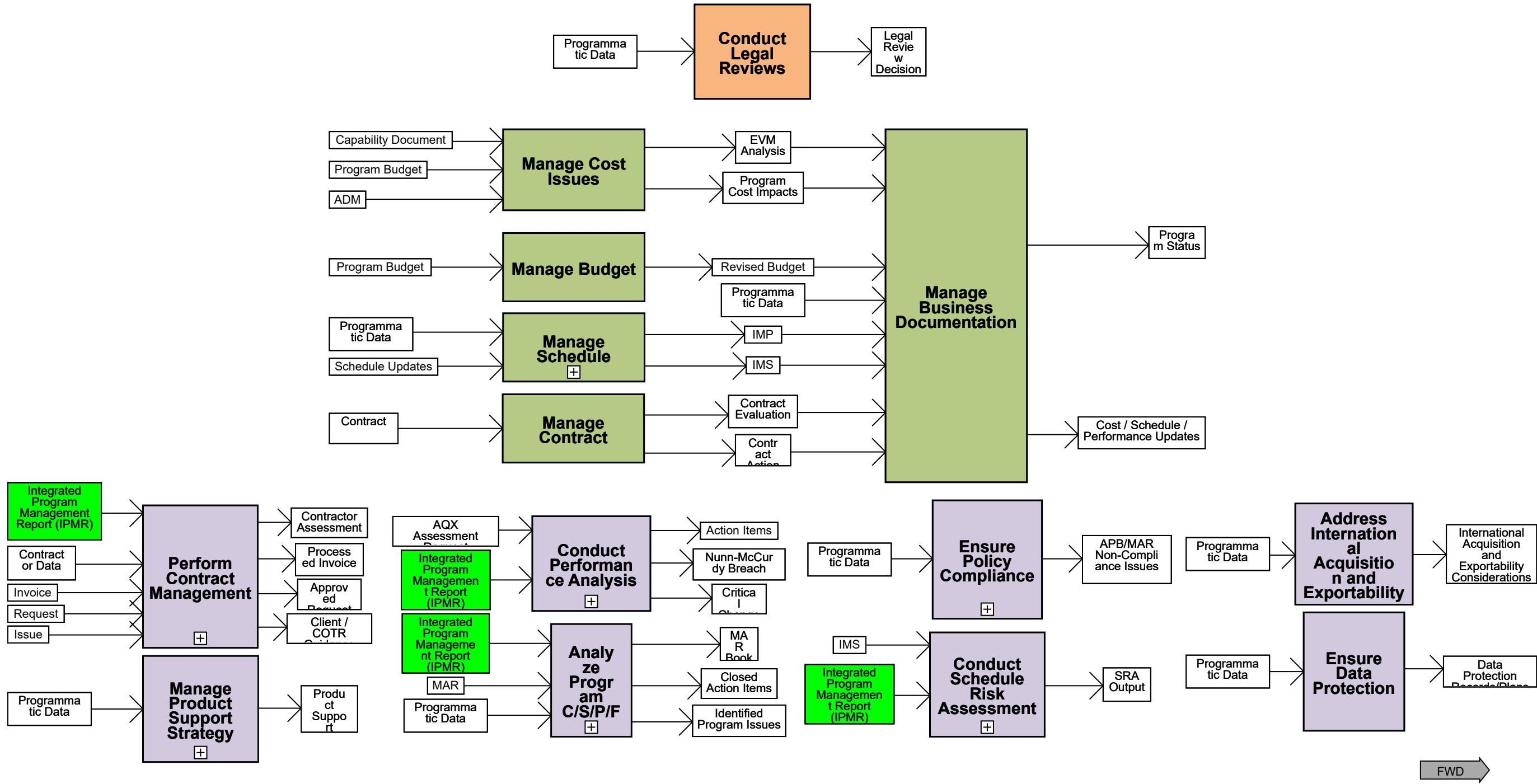

Go Up 1 Level

Acquisition Process Model

1.5.1.1.10 Ensure Policy Compliance

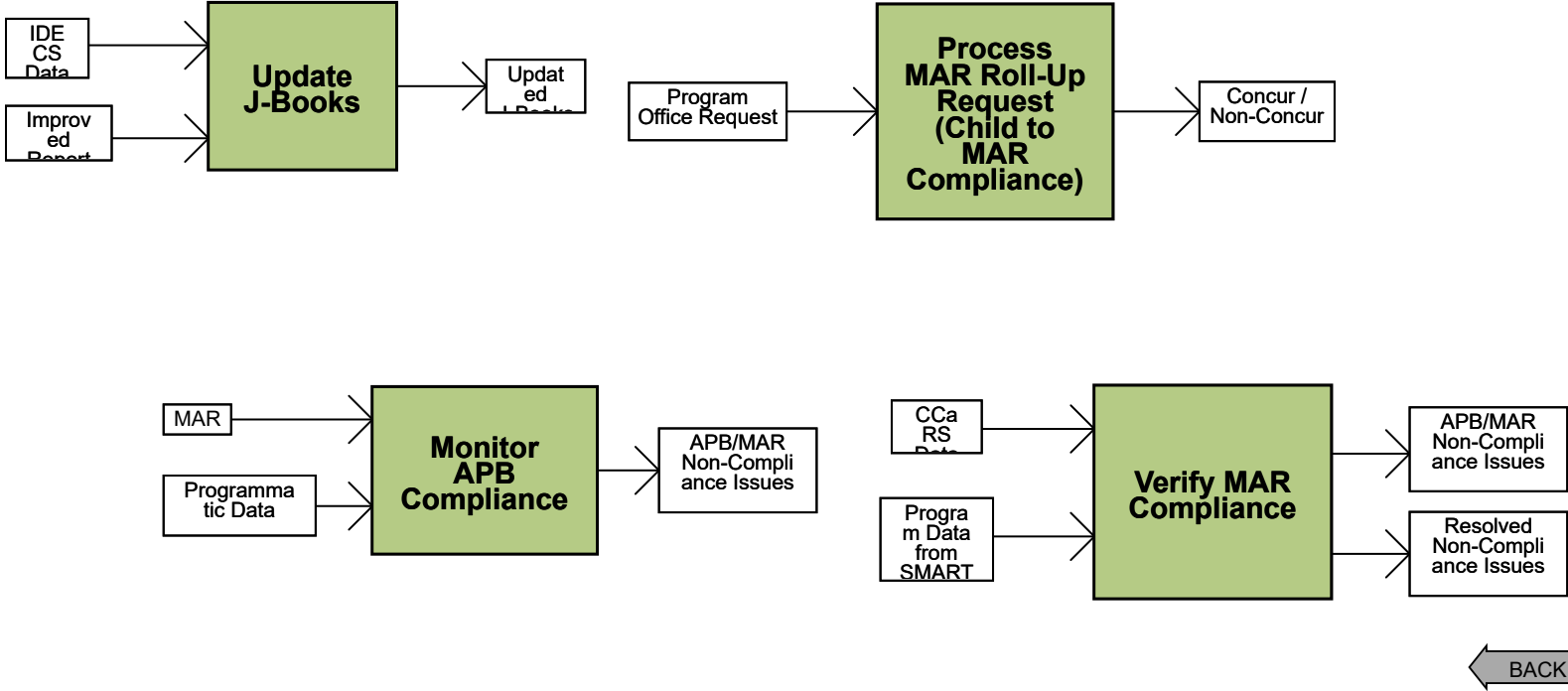

Acquisition Process Model

1.5.1.1.11 Conduct Schedule Risk Assessment

Go Up 1 Level

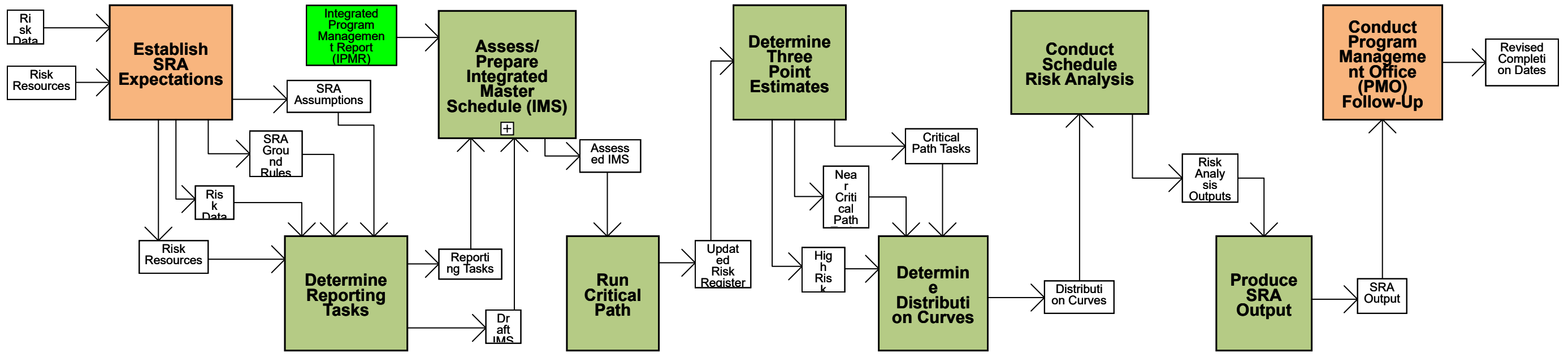

BACK

FWD

Acquisition Process Model

1.5.1.1.11.3 Conduct Integrated Master Schedule (IMS) Assessment Process

Go Up 1 Level

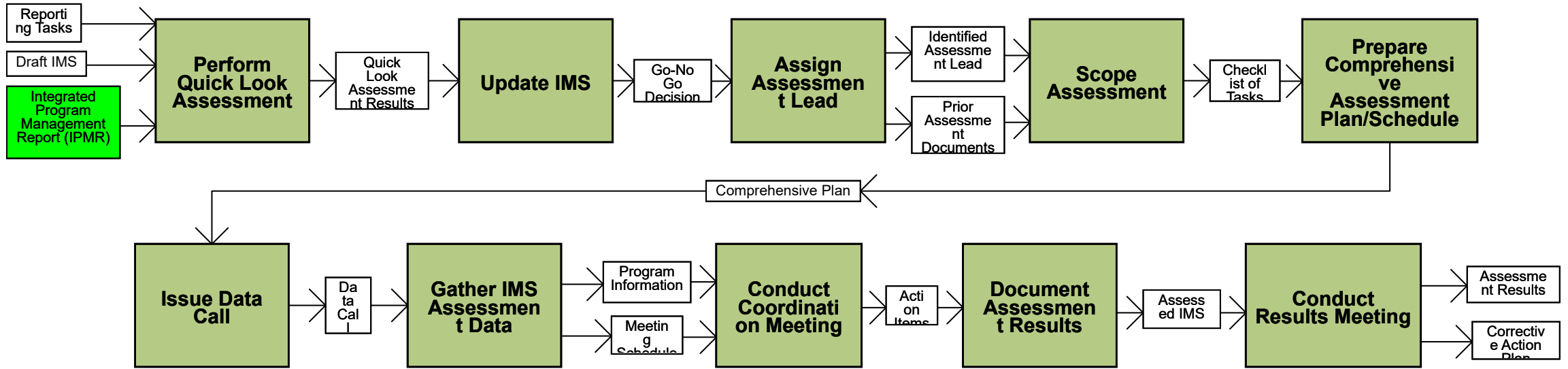

Go Up 1 Level

Acquisition Process Model

1.5.1.1.12 Manage Product Support Strategy

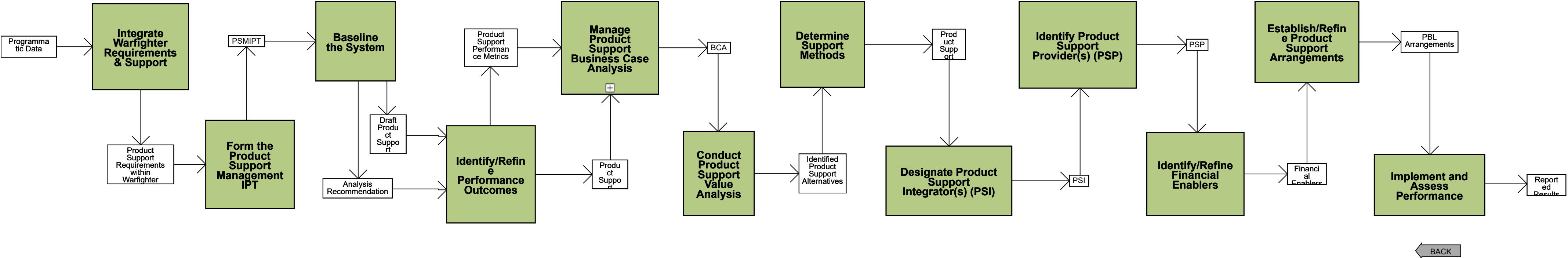

Acquisition Process Model

1.5.1.1.12.5 Manage Product Support Business Case Analysis

AFLCMC Standard Processes

Go Up 1 Level

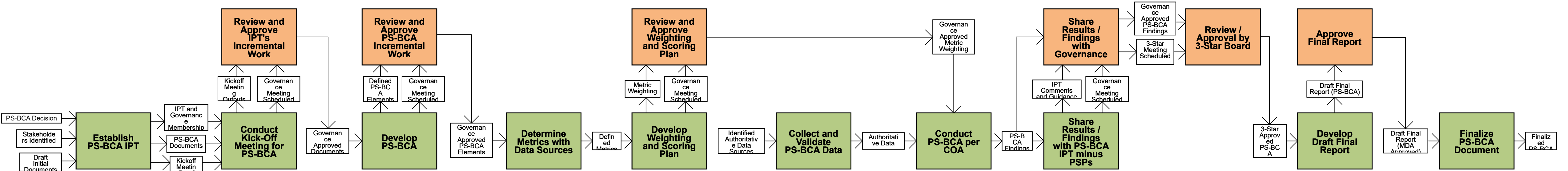

Note: This is an AFLCMC Standard Process.

Go Up 1 Level

Acquisition Process Model

1.5.1.1.3 Manage Schedule

AFLCMC
Standard
Processes

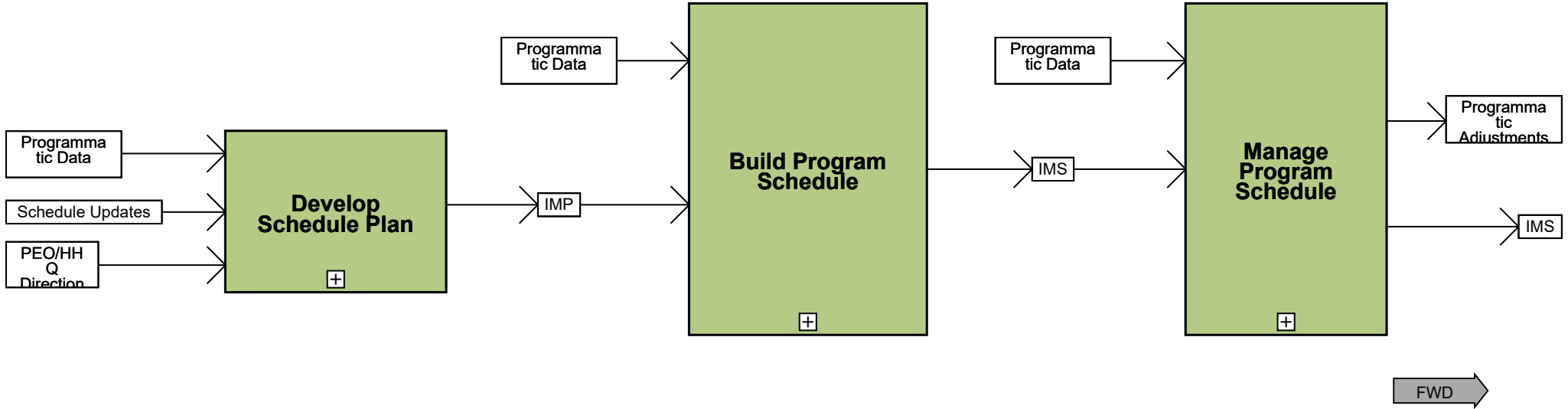

Note: The process above is an AFLCMC Process Guide (Schedule Management Fundamentals).

Go Up 1 Level

Acquisition Process Model

1.5.1.1.3.1 Develop Schedule Plan

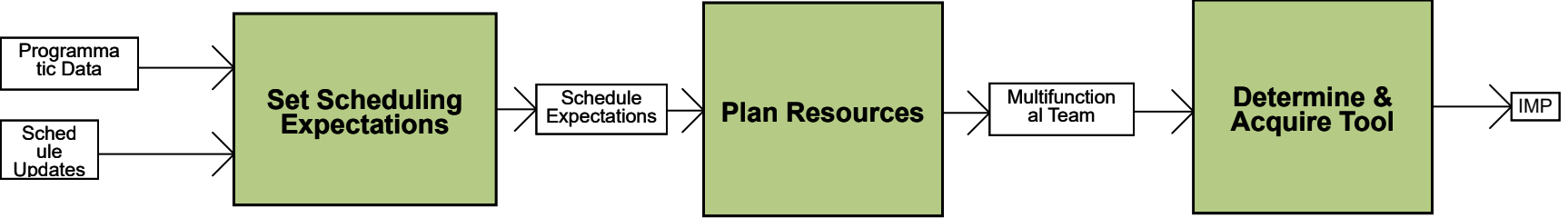

Note: The process above is an AFLCMC Process Guide (Schedule Management Fundamentals).

FWD

Go Up 1 Level

Acquisition Process Model

1.5.1.1.3.2 Build Program Schedule

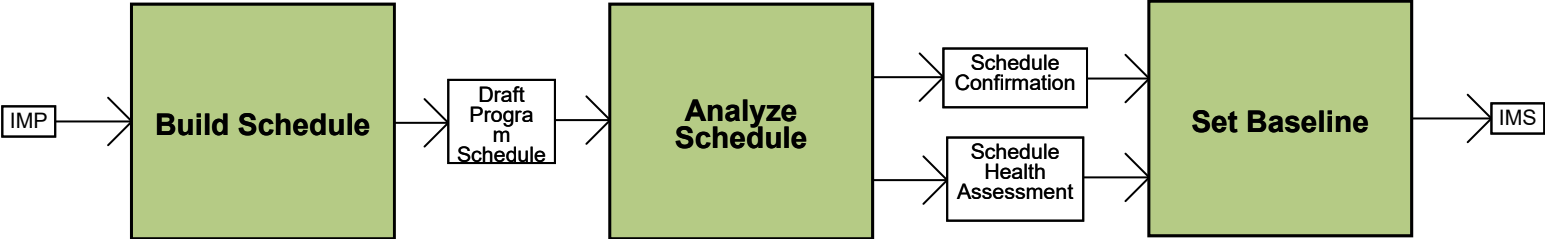

Note: The process above is an AFLCMC Process Guide (Schedule Management Fundamentals).

BACK FWD

Acquisition Process Model

1.5.1.1.3.3 Manage Program Schedule

Go Up 1 Level

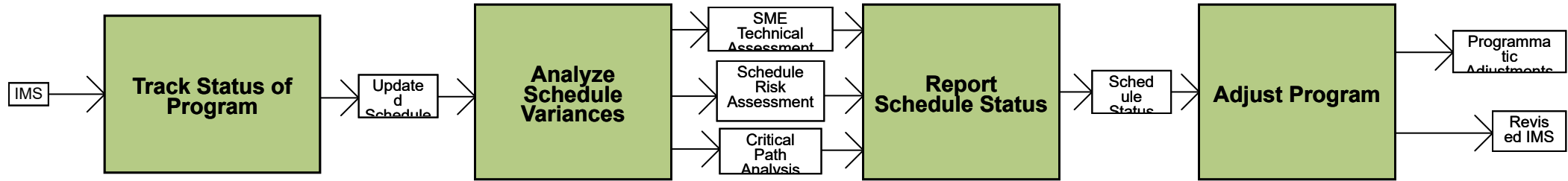

Note: The process above is an AFLCMC Process Guide (Schedule Management Fundamentals).

← BACK

Go Up 1 Level

Acquisition Process Model

1.5.1.1.6 Perform Contract Management

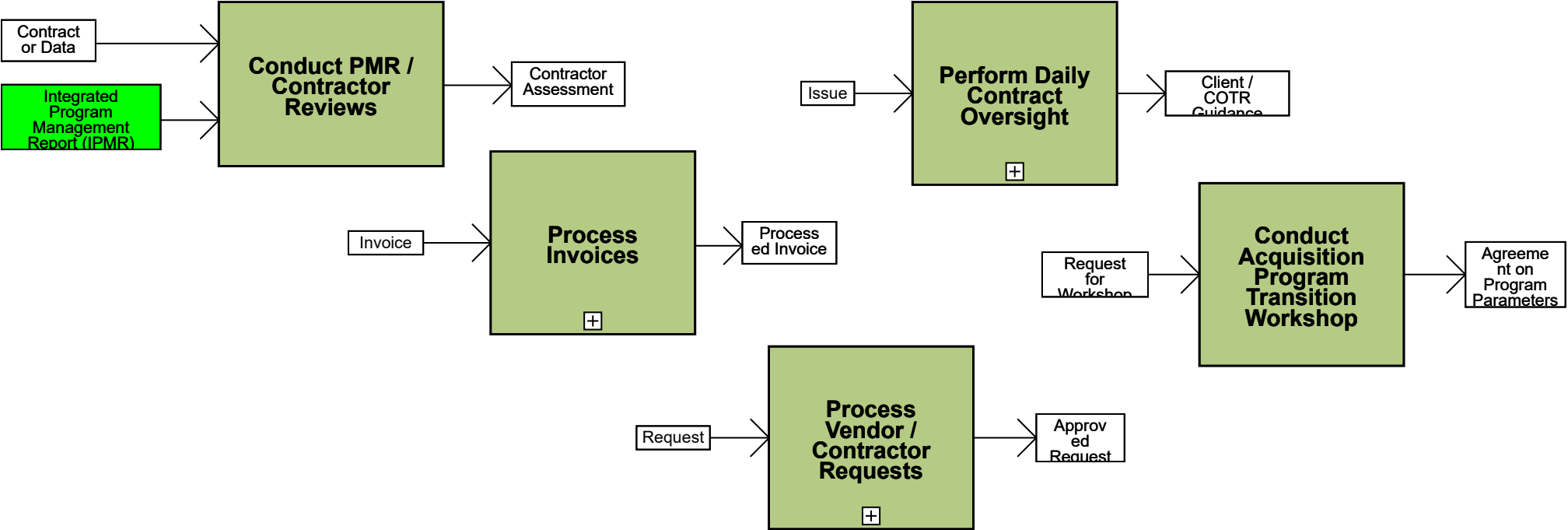

← BACK

FWD →

Go Up 1 Level

Acquisition Process Model

1.5.1.1.6.2 Process Invoices

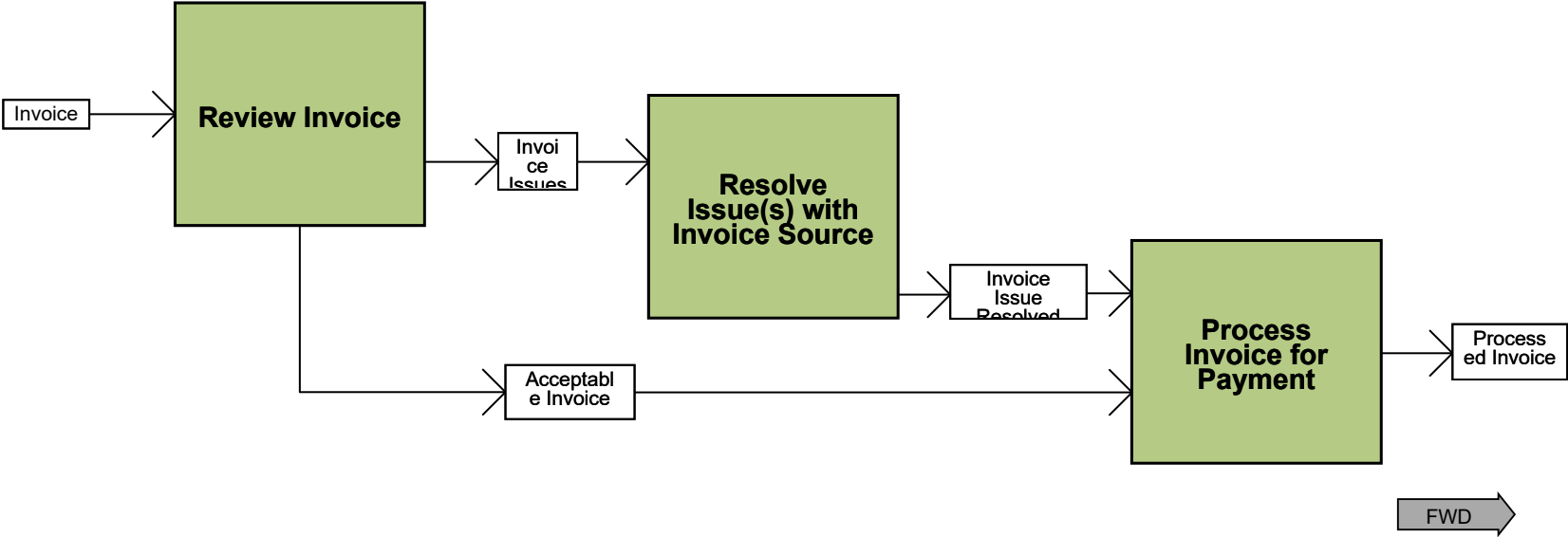

Go Up 1 Level

Acquisition Process Model

1.5.1.1.6.3 Process Vendor / Contractor Requests

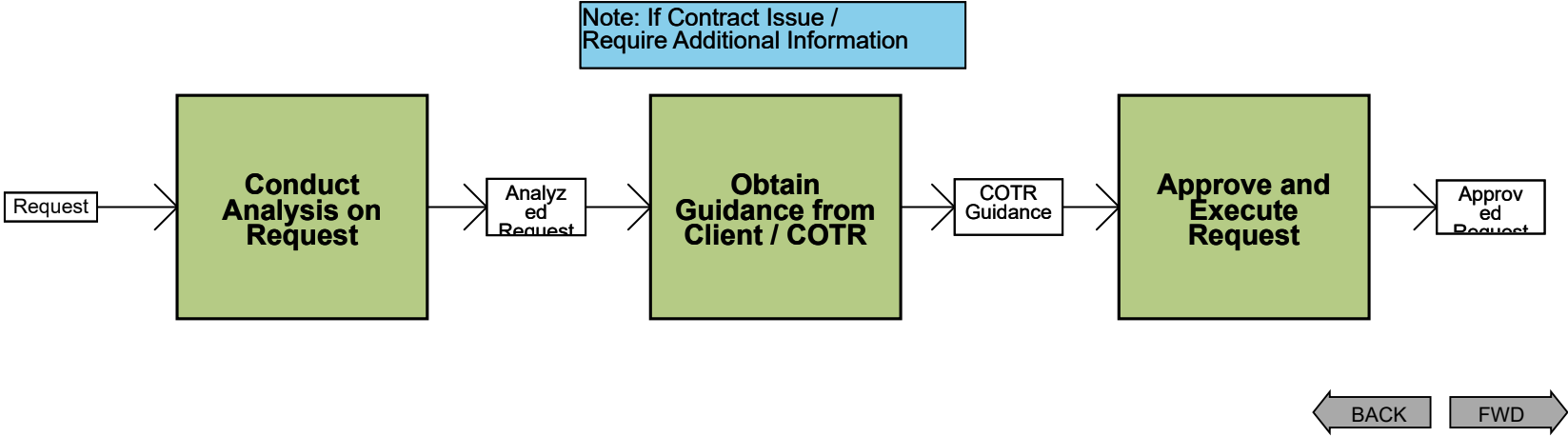

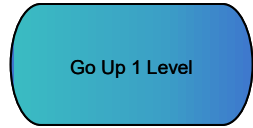

Acquisition Process Model

1.5.1.1.6.4 Perform Daily Contract Oversight

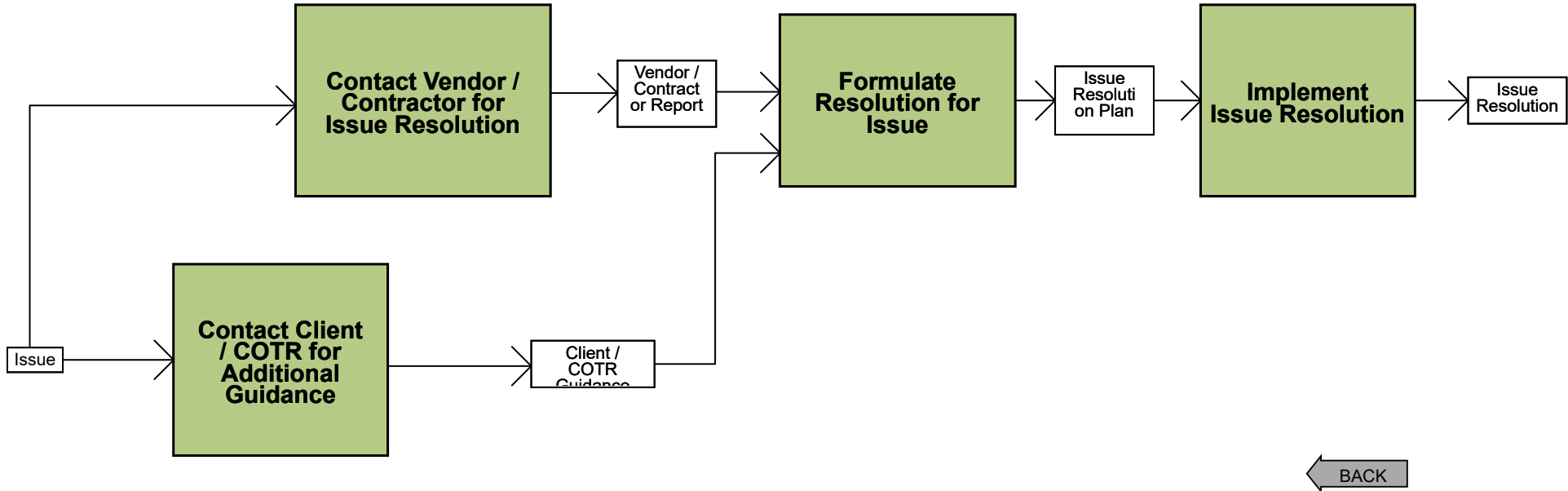

Go Up 1 Level

Acquisition Process Model

1.5.1.1.8 Conduct Performance Analysis

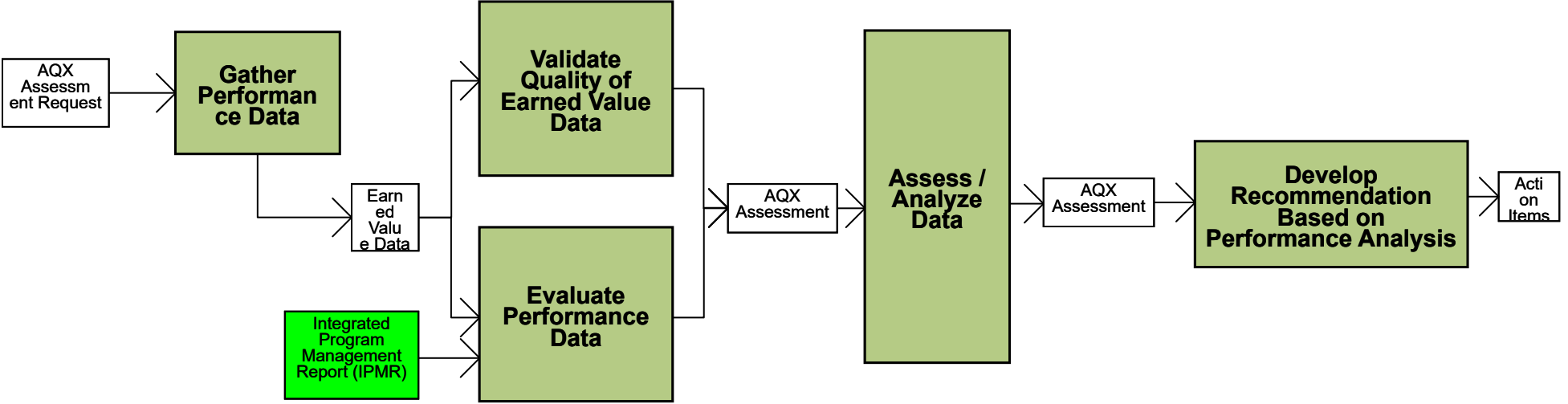

BACK FWD

Go Up 1 Level

Acquisition Process Model

1.5.1.1.9 Analyze Program C-S-P-F

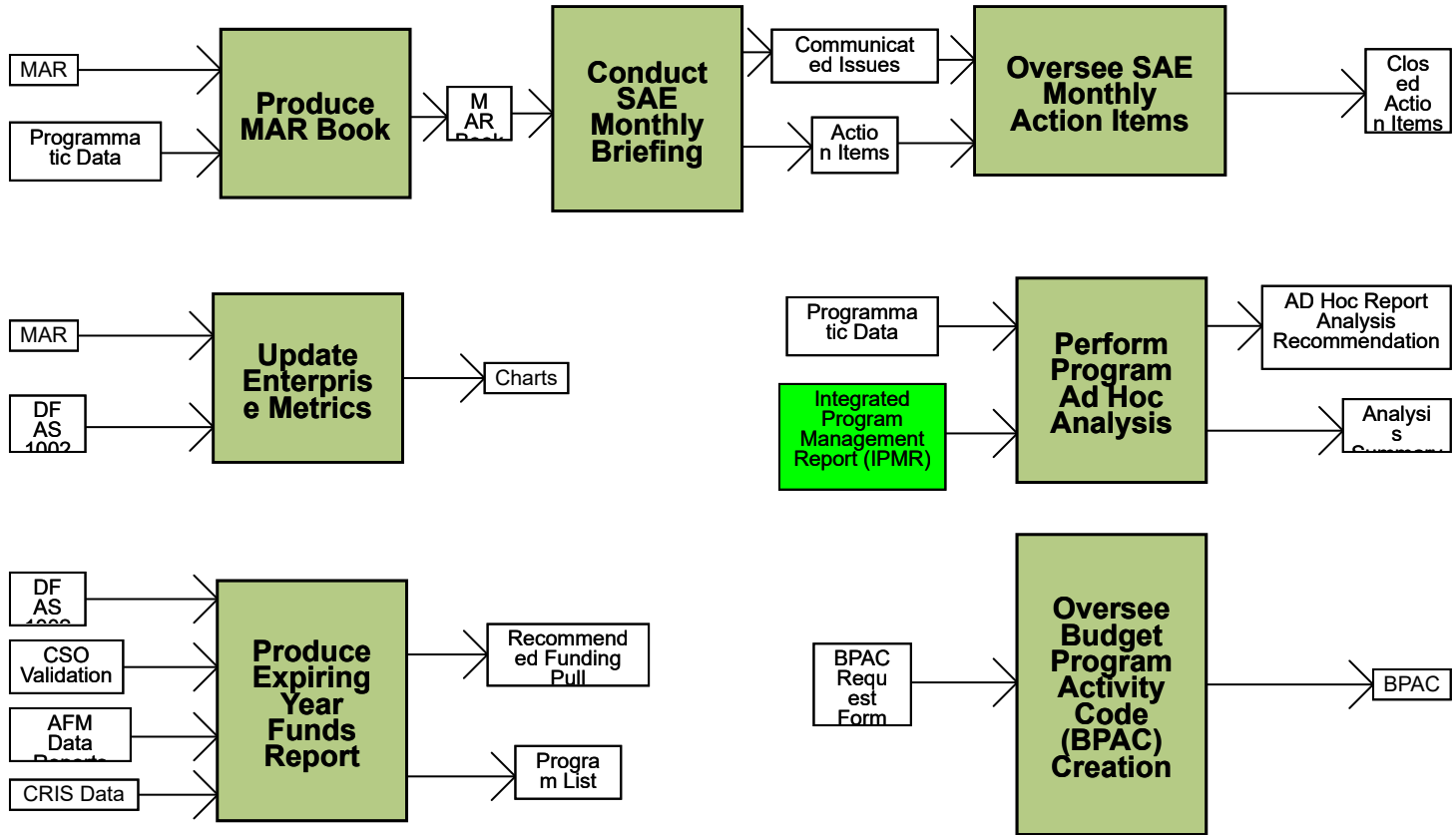

← BACK FWD →

Go Up 1 Level

Acquisition Process Model

1.5.1.2 Manage Technical Activities

PEO View

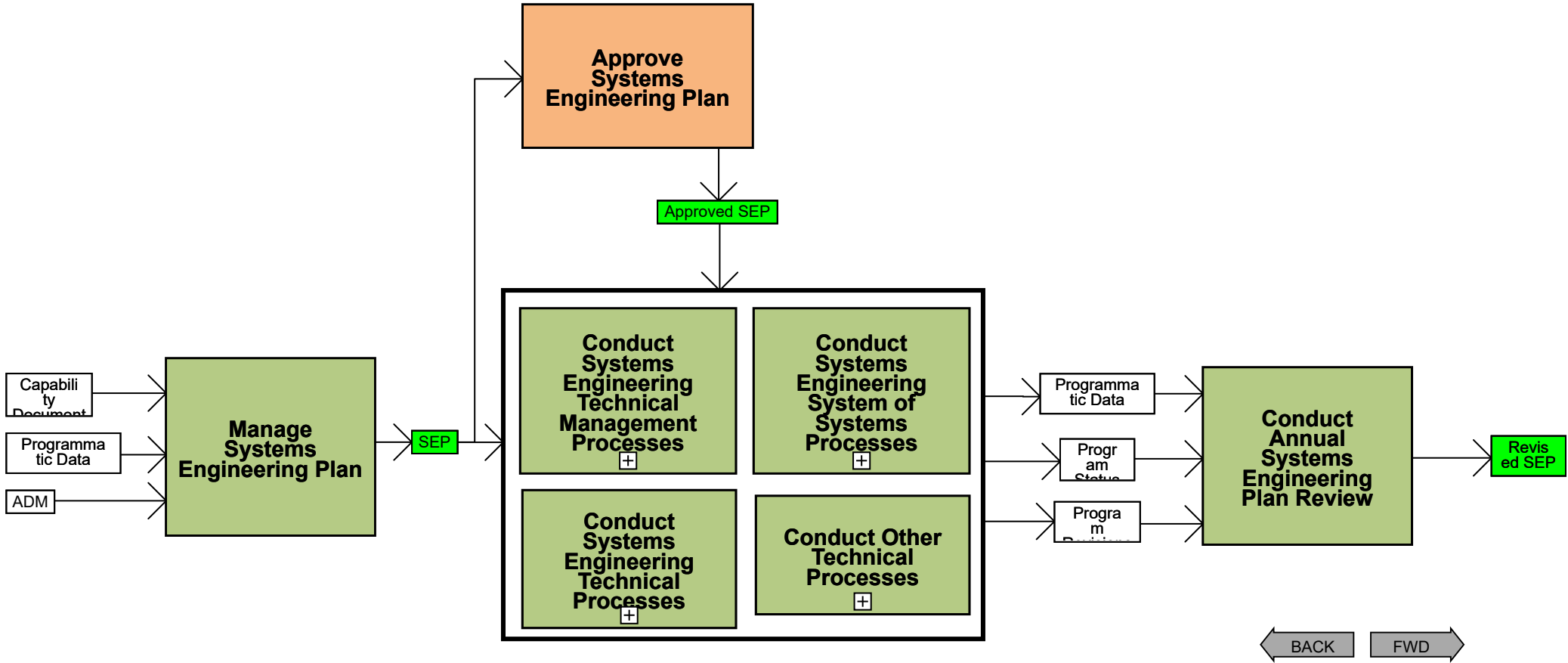

Go Up 1 Level

Acquisition Process Model

1.5.1.2.2 Conduct Systems Engineering Technical Management Processes

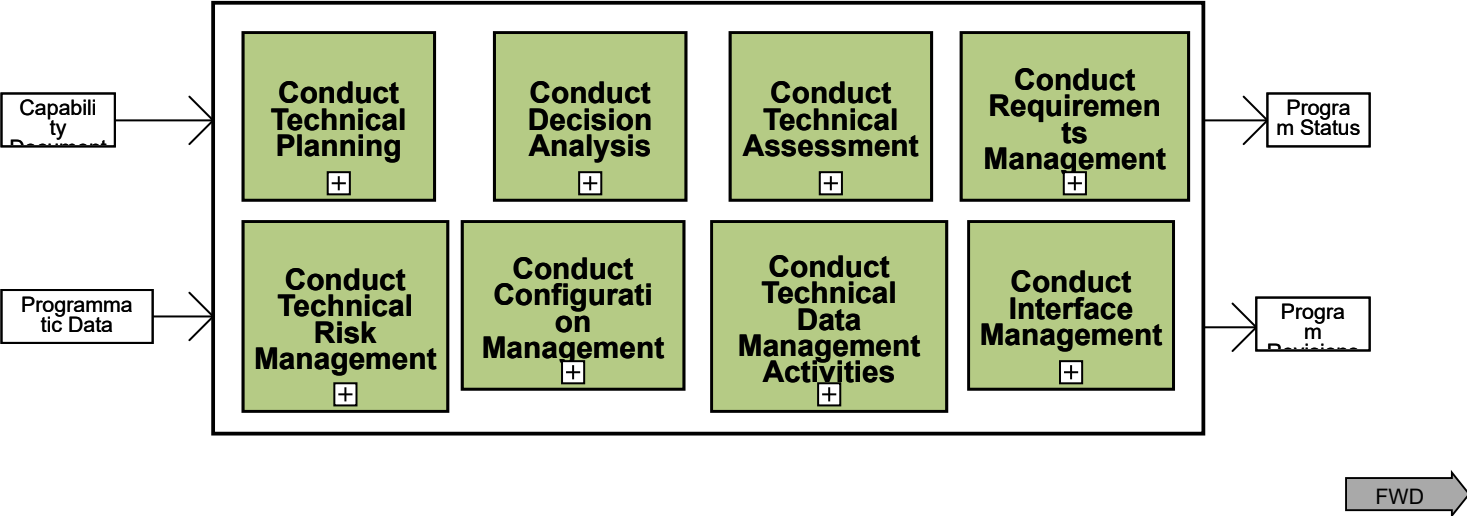

Go Up 1 Level

Acquisition Process Model

1.5.1.2.2.1 Conduct Technical Planning

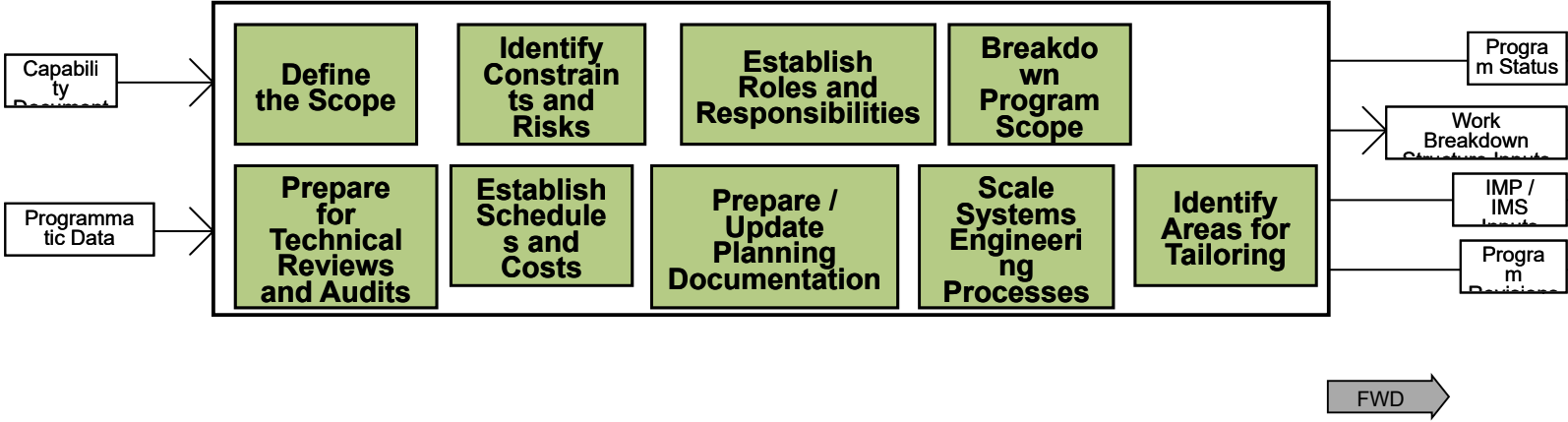

Go Up 1 Level

Acquisition Process Model

1.5.1.2.2.2 Conduct Decision Analysis

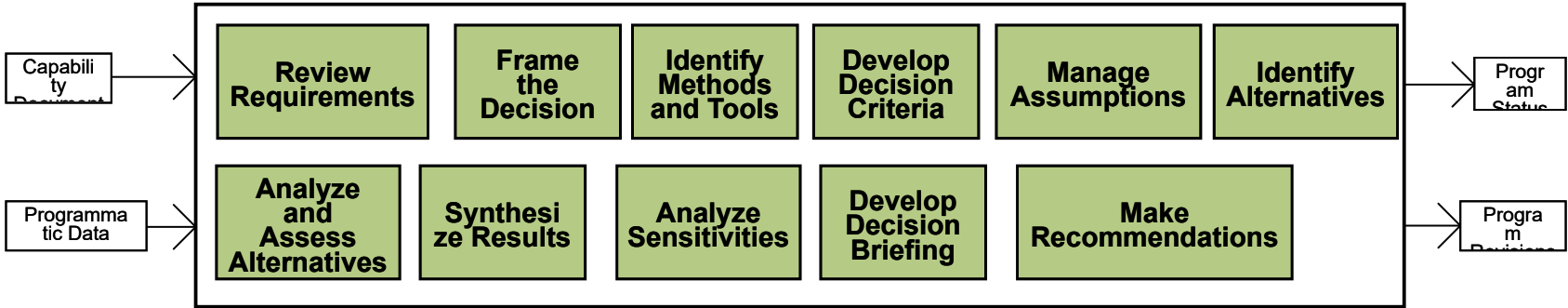

← BACK FWD →

Acquisition Process Model

1.5.1.2.2.3 Conduct Technical Assessment

Go Up 1 Level

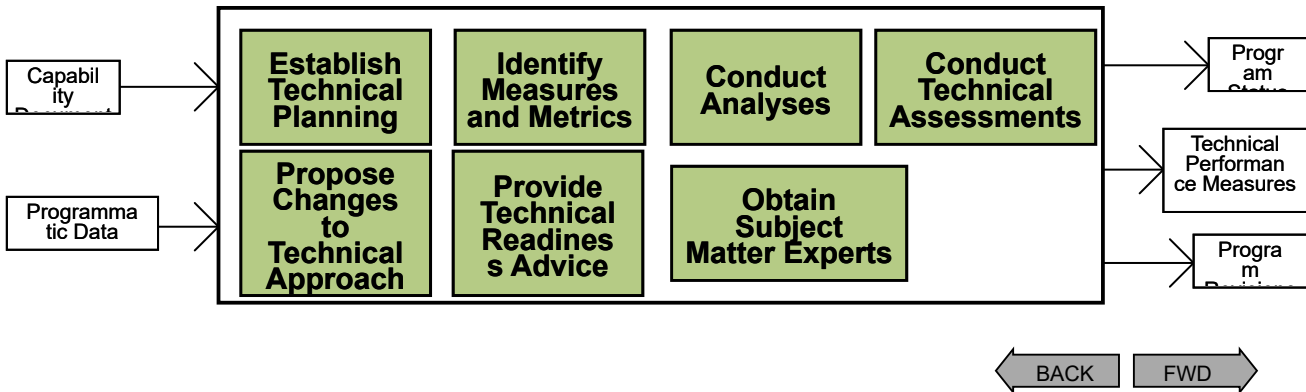

Go Up 1 Level

Acquisition Process Model

1.5.1.2.2.4 Conduct Requirements Management

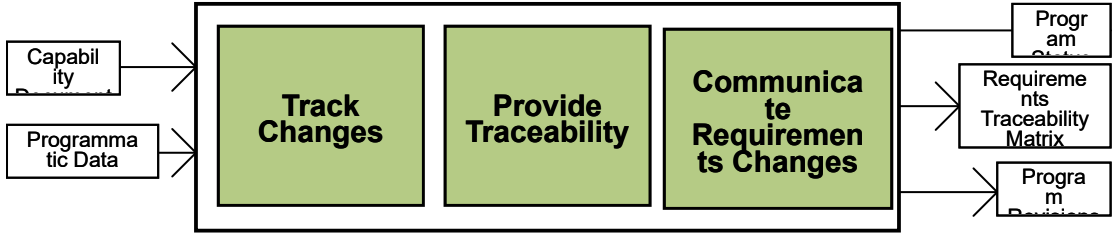

BACK FWD

Go Up 1 Level

Acquisition Process Model

1.5.1.2.2.5 Conduct Technical Risk Management

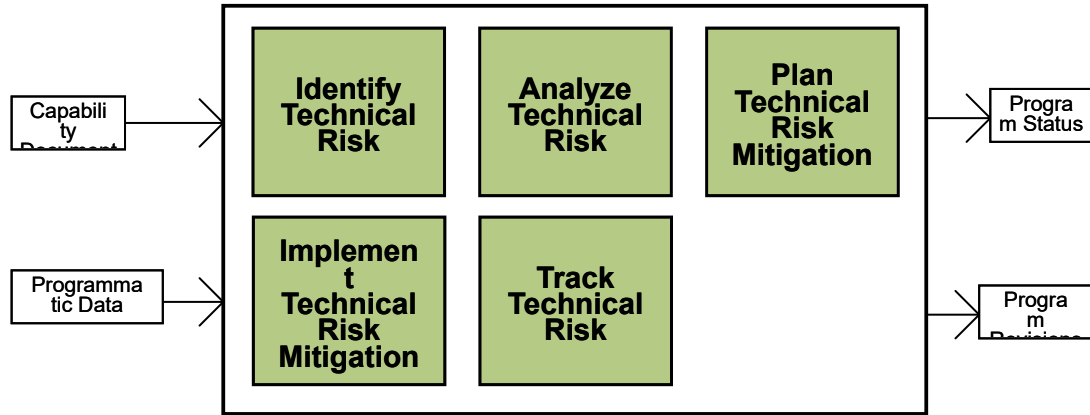

Note: The Technical Risk Management process above is modeled on the overall Risk Management process included at 1.5.3 (hyperlinked from this note).

← BACK FWD →

Go Up 1 Level

Acquisition Process Model

1.5.1.2.2.6 Conduct Configuration Management

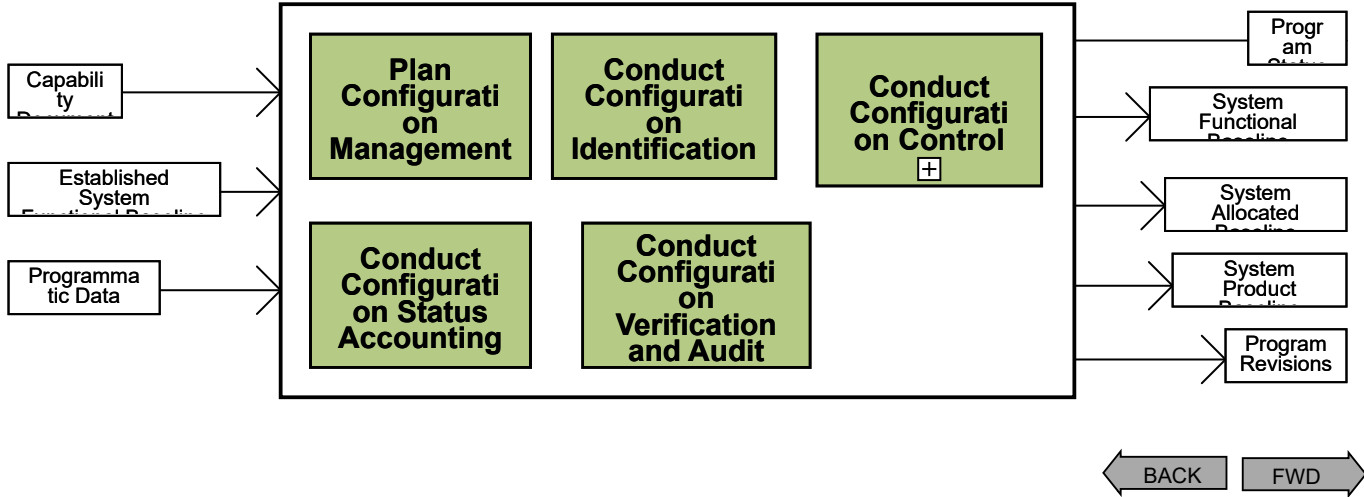

Go Up 1 Level

Acquisition Process Model

1.5.1.2.2.6.3 Conduct Change Control

AFLCMC
Standard
Processes

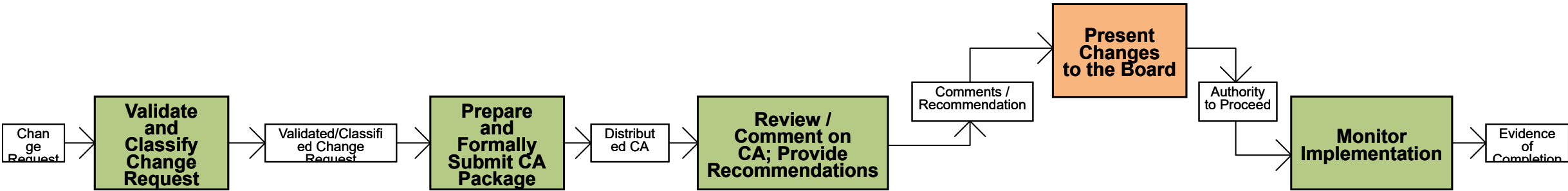

Note: This is an AFLCMC Standard Process (formerly titled Configuration Control and now titled Change Control)

Go Up 1 Level

Acquisition Process Model

1.5.1.2.2.7 Conduct Technical Data Management Activities

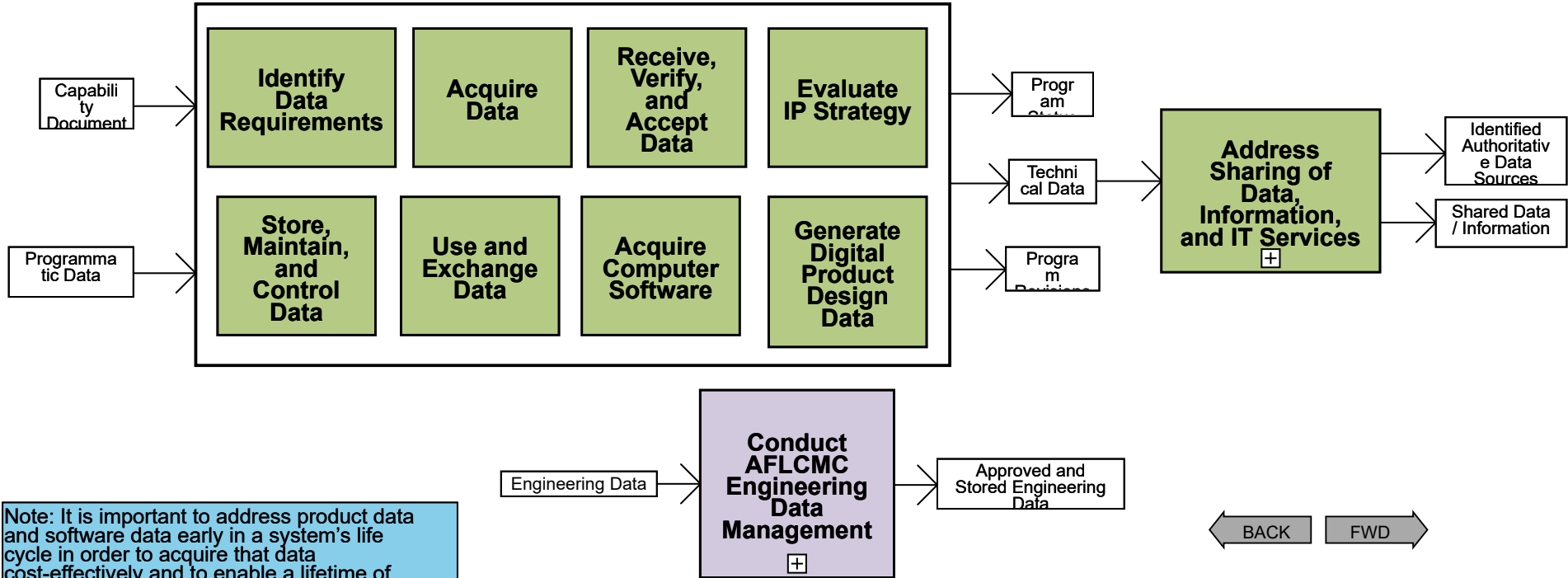

Note: It is important to address product data and software data early in a system's life cycle in order to acquire that data cost-effectively and to enable a lifetime of competitive sustainment and compliance with public law. AFPAM 63-128, Section 11.1

Go Up 1 Level

Acquisition Process Model

1.5.1.2.2.7.10 Address Sharing of Data, Information, and IT Services

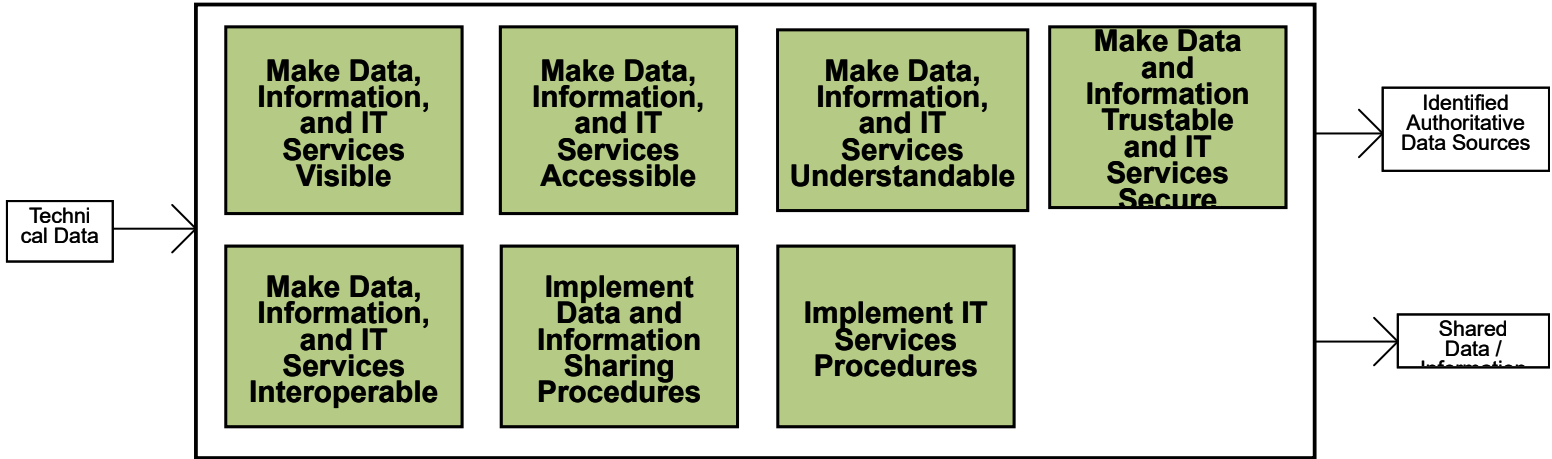

← BACK



Acquisition Process Model

1.5.1.2.2.8 Conduct Interface Management

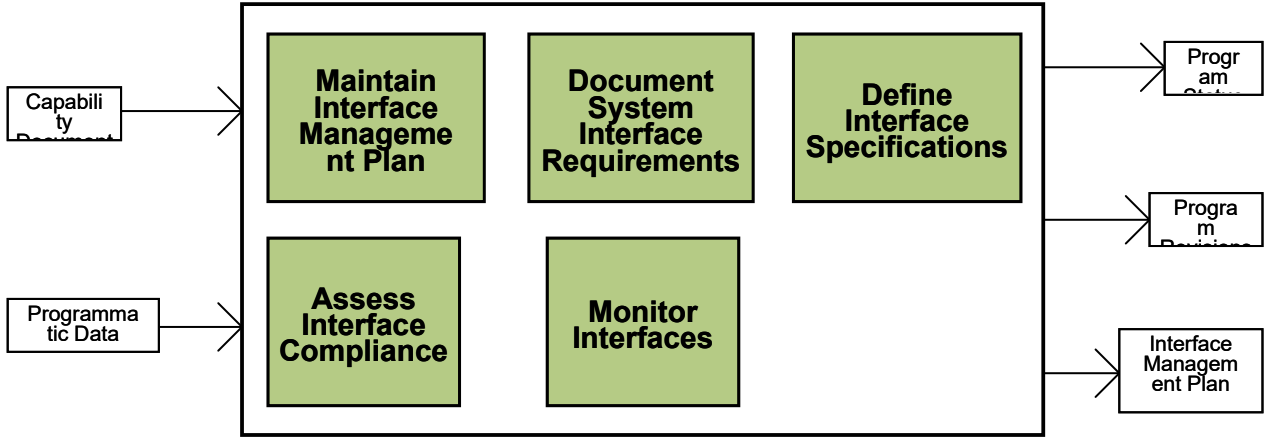

Go Up 1 Level

Acquisition Process Model

1.5.1.2.3 Conduct Systems Engineering Technical Processes

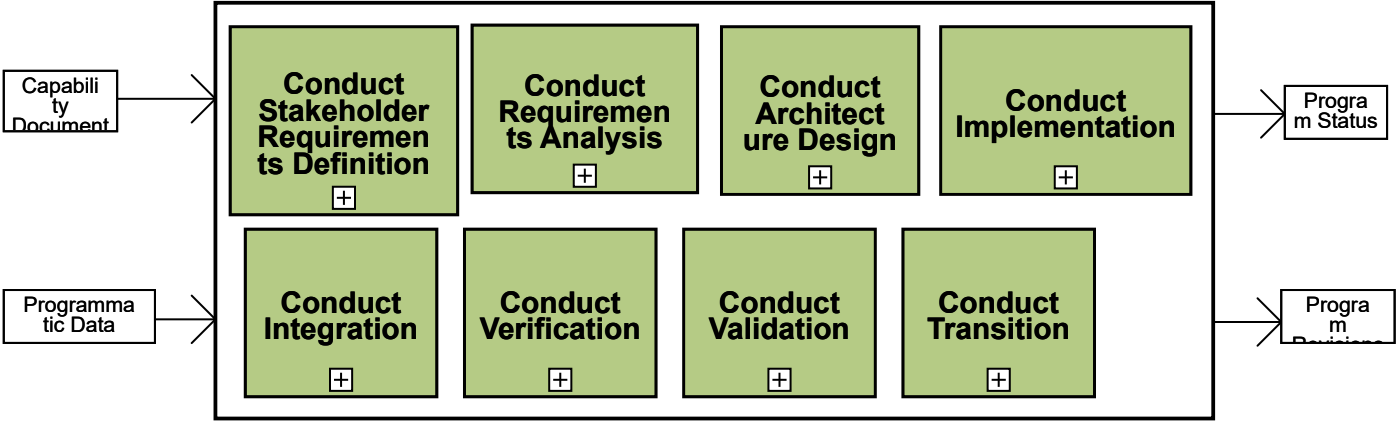

BACK FWD

Go Up 1 Level

Acquisition Process Model

1.5.1.2.3.1 Conduct Stakeholder Requirements Definition

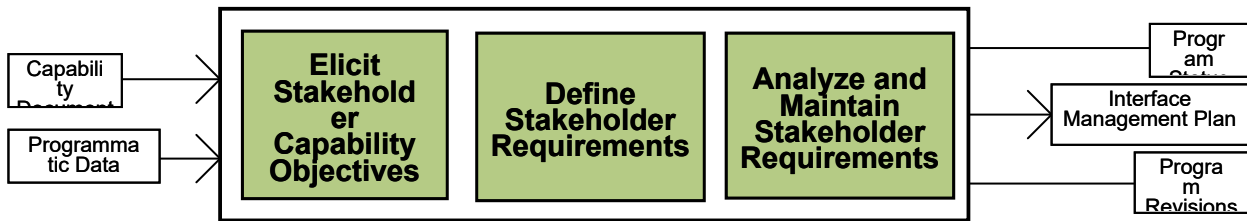

FWD

Acquisition Process Model

1.5.1.2.3.2 Conduct Requirements Analysis

Go Up 1 Level

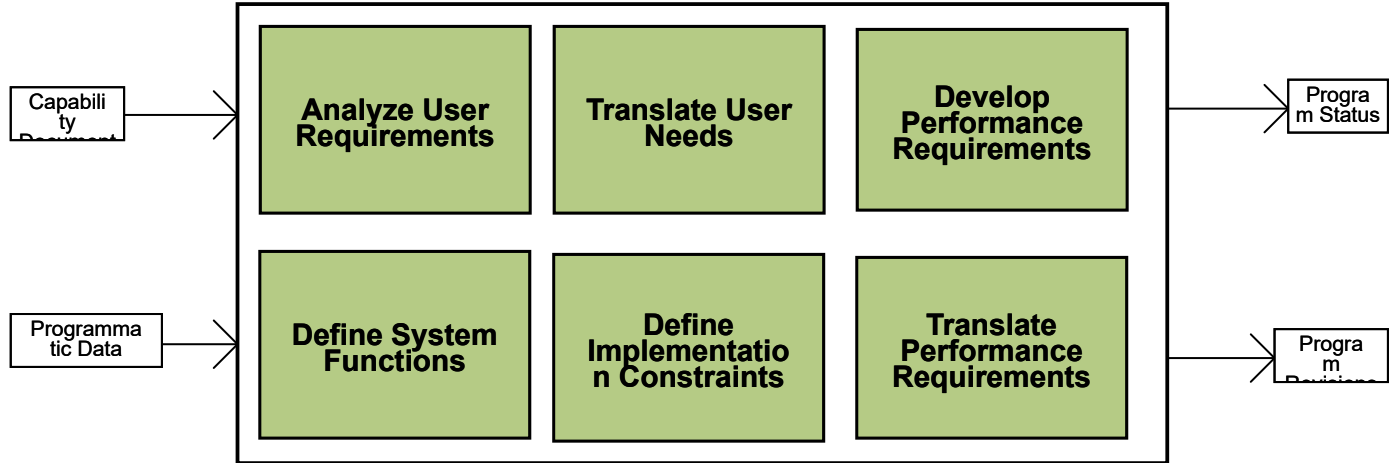

BACK

FWD

Go Up 1 Level

Acquisition Process Model

1.5.1.2.3.3 Conduct Architecture Design

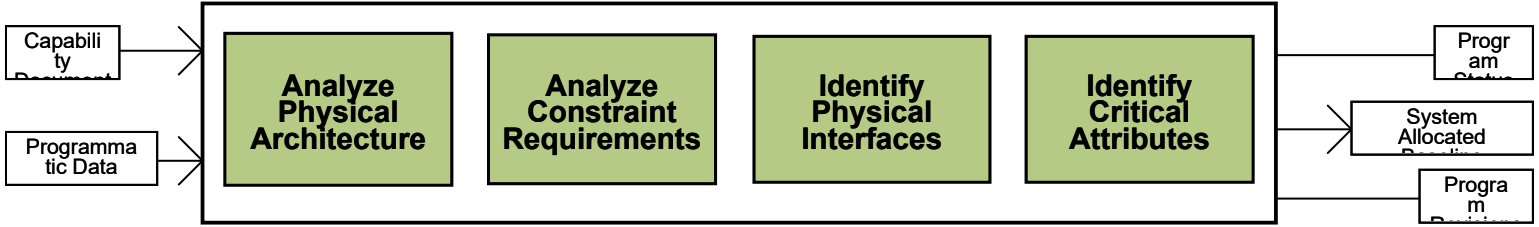

← BACK

FWD →

Go Up 1 Level

Acquisition Process Model

1.5.1.2.3.4 Conduct Implementation

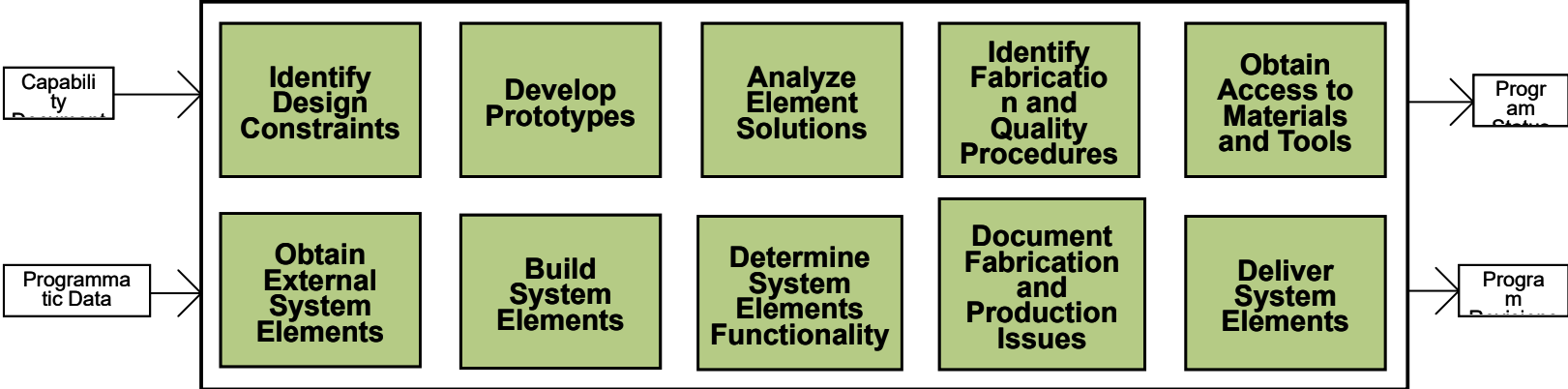

← BACK FWD →

Go Up 1 Level

Acquisition Process Model

1.5.1.2.3.5 Conduct Integration

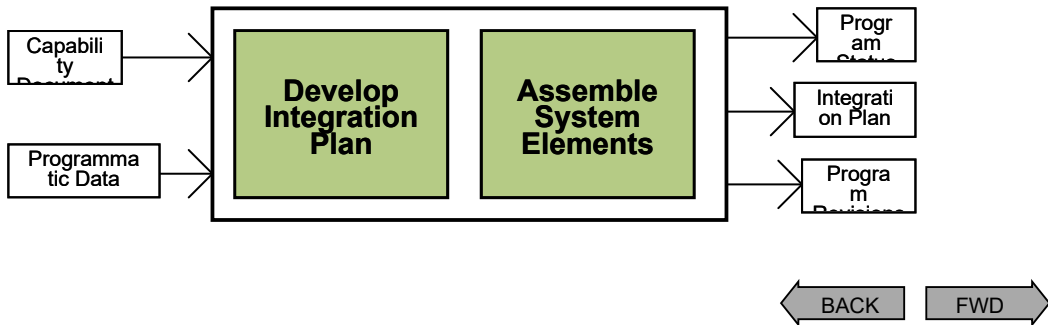

Go Up 1 Level

Acquisition Process Model

1.5.1.2.3.6 Conduct Verification

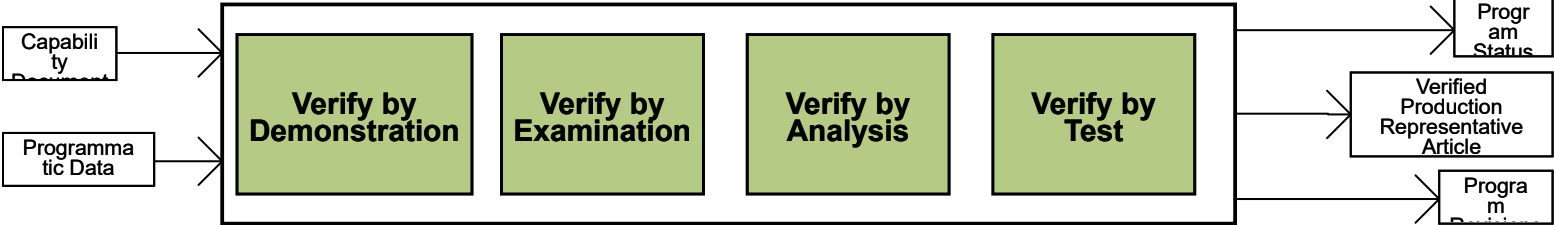

← BACK

FWD →

Go Up 1 Level

Acquisition Process Model

1.5.1.2.3.7 Conduct Validation

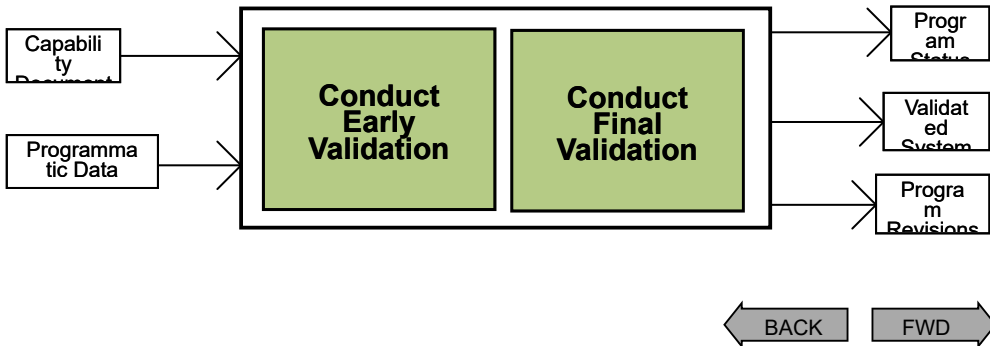

Go Up 1 Level

Acquisition Process Model

1.5.1.2.3.8 Conduct Transition

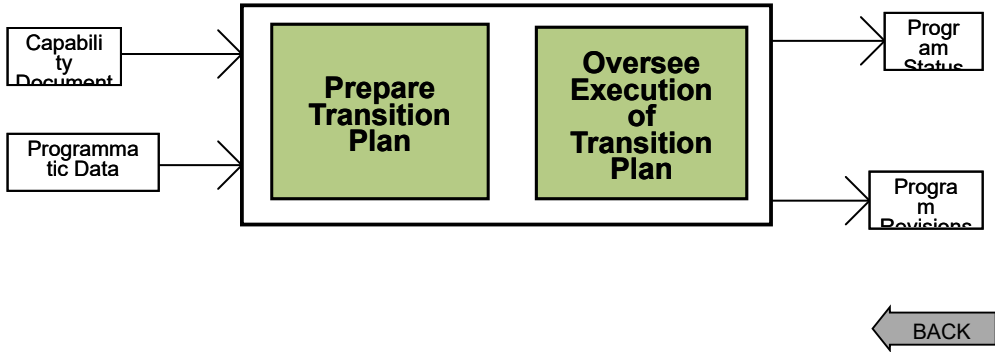

Acquisition Process Model

1.5.1.2.6 Conduct Other Technical Processes

Go Up 1 Level

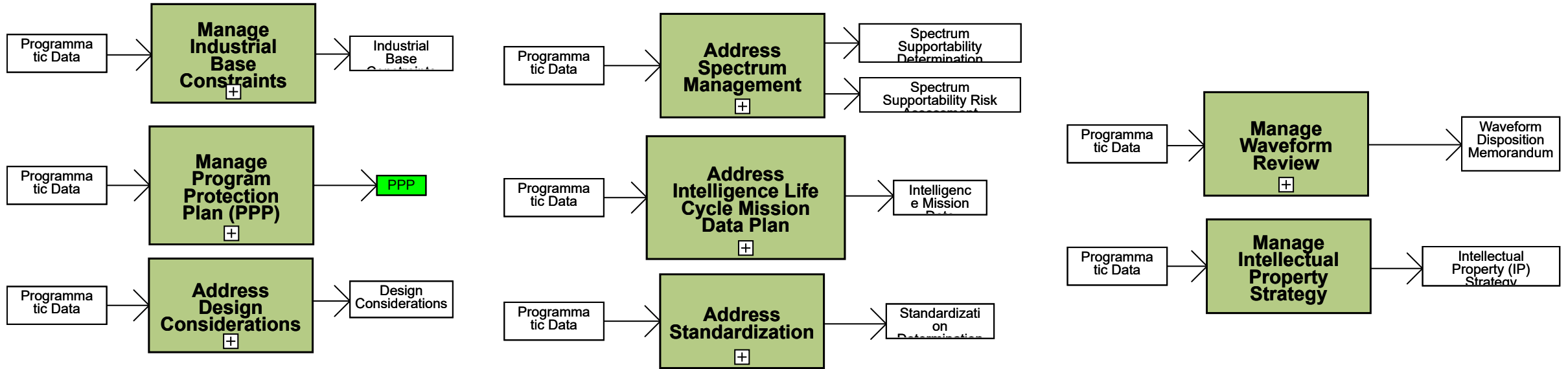

Note: The 29 Design Considerations listed in Chapter 5 of AFI 63-101/20-101 are as follow: Recorded Aircraft Information; Mission Assurance for Space Programs; Product and System Integrity; Air Force Metrology and Calibration; Accessibility; Affordability-SE Tradeoff Analysis; Anti-Counterfeiting; Commercial-Off-the-Shelf; Corrosion Prevention and Control; Critical Safety Items; Diminishing Manufacturing Sources & Material Shortages; Disposal and Demilitarization; Environment, Safety, and Occupational Health; Human Factors Engineering; Insensitive Munitions; Intelligence; Item Unique Identification; Interoperability & Dependency; Open Systems; Operational Energy; Packaging, Handling, Storage and Transportation; Producibility, Quality & Manufacturing Readiness; Program Protection Planning; Reliability and Maintainability Engineering; Software Engineering; Spectrum Management; Standardization; Supportability; and System Survivability & Susceptibility;

BACK FWD

Go Up 1 Level

Acquisition Process Model

1.5.1.2.6.1 Manage Industrial Base Constraints

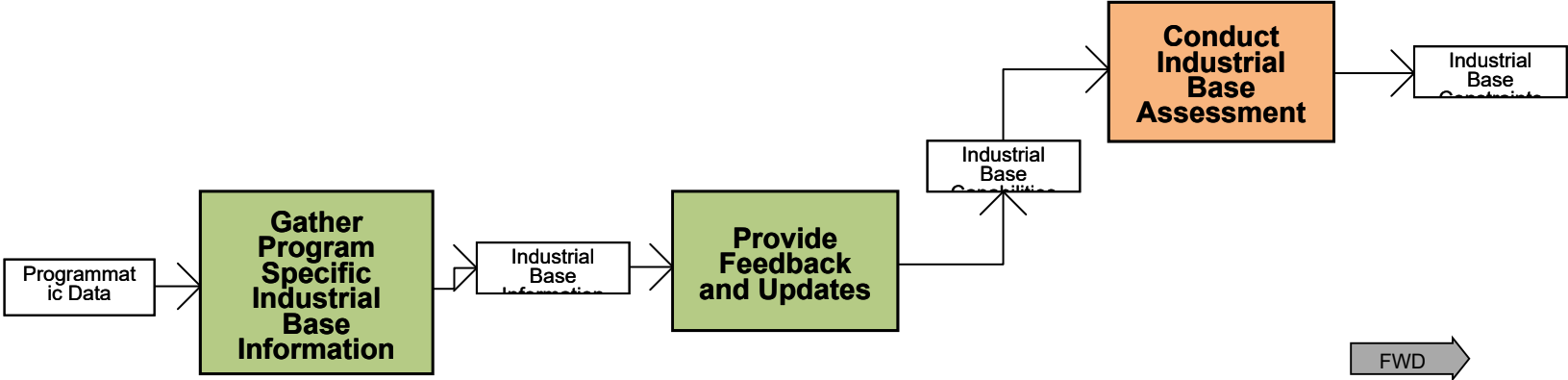

Go Up 1 Level

Acquisition Process Model

1.5.1.2.6.2 Manage Program Protection Plan (PPP)

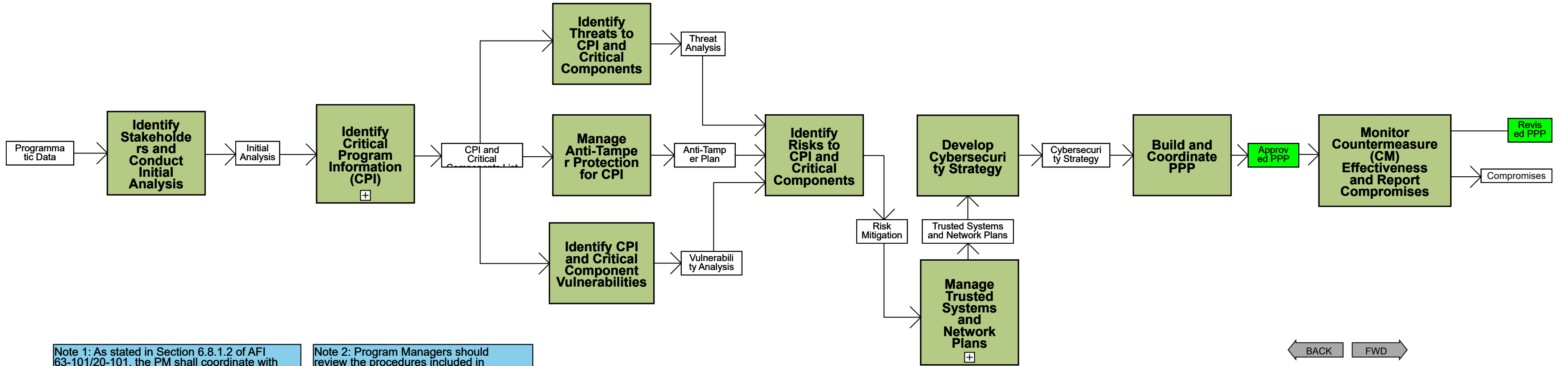

Note 1: As stated in Section 6.8.1.2 of AFI 63-101/20-101, the PM shall coordinate with the Implementing Command's TSN focal point regarding TSN threat identification, best practices, processes, techniques and procurement tools. For more information see DoDI 5200.44 and AFPAM 63-113. Click here to access an active link to these documents.

Note 2: Program Managers should review the procedures included in DoDI 8500.01 as part of Cybersecurity considerations. Click here to access an active link to the document.

BACK FWD

Go Up 1 Level

Acquisition Process Model

1.5.1.2.6.2.2 Identify Critical Program Information (CPI)

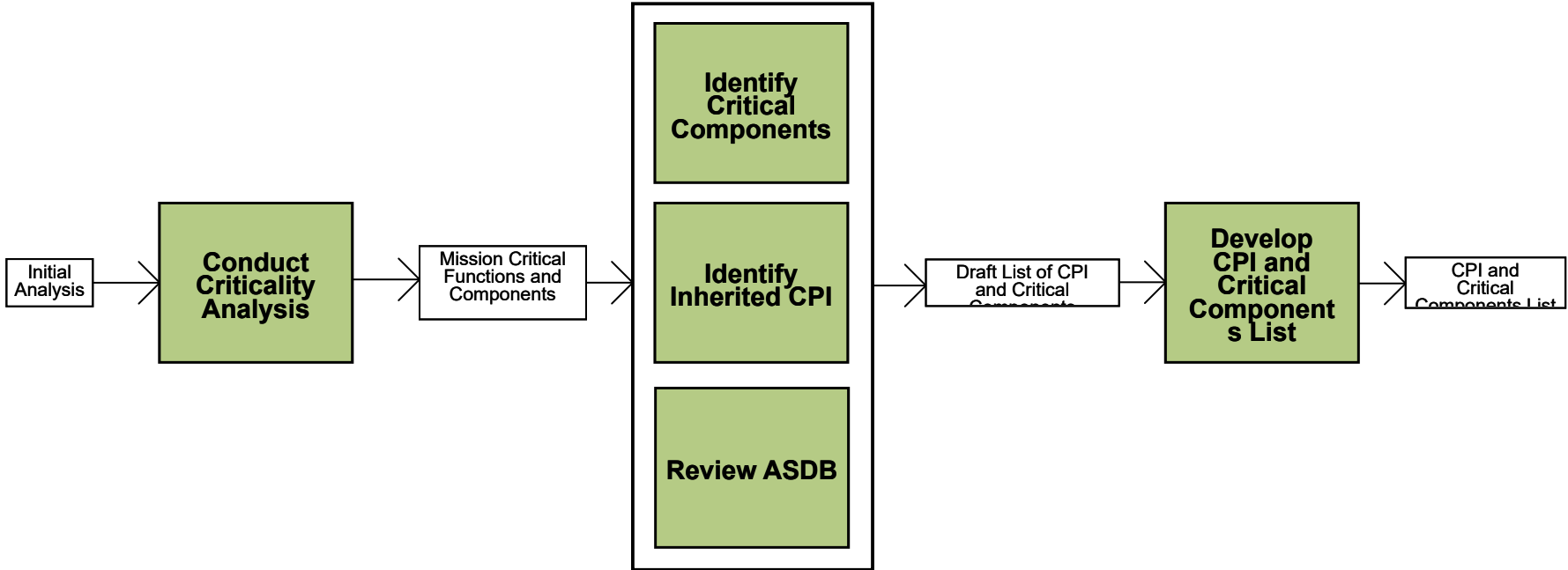

Acquisition Process Model

1.5.1.2.6.2.7 Manage Trusted Systems and Network Plans

Go Up 1 Level

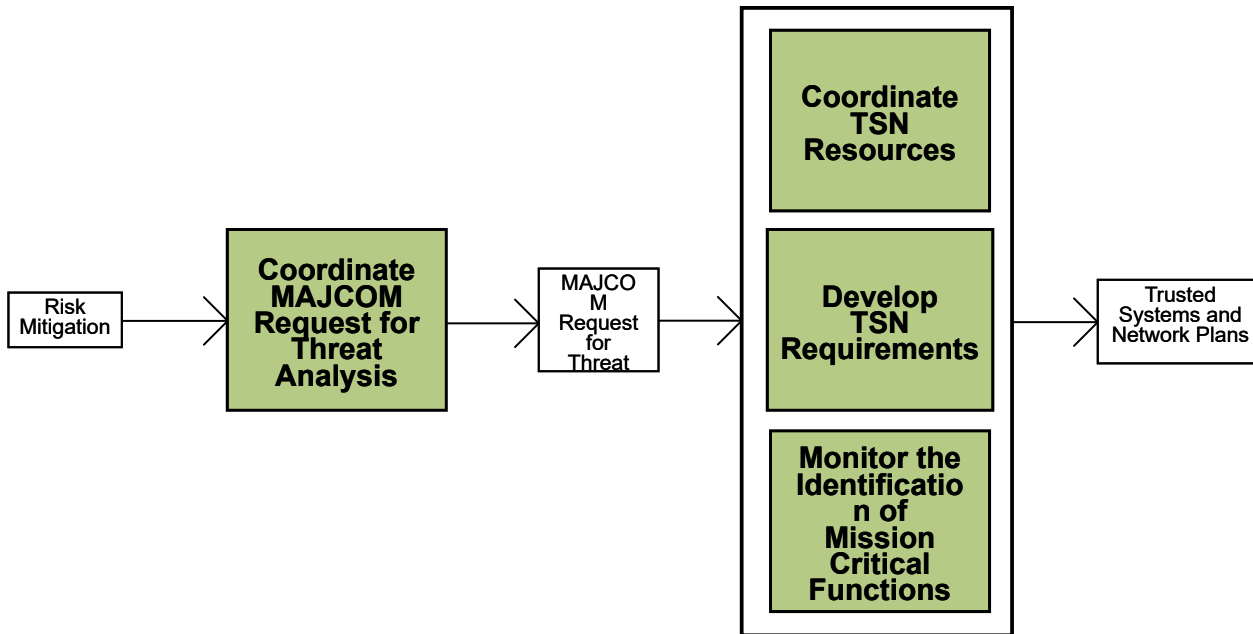

Acquisition Process Model

1.5.1.2.6.3 Address Design Considerations

Go Up 1 Level

Programmatic Data

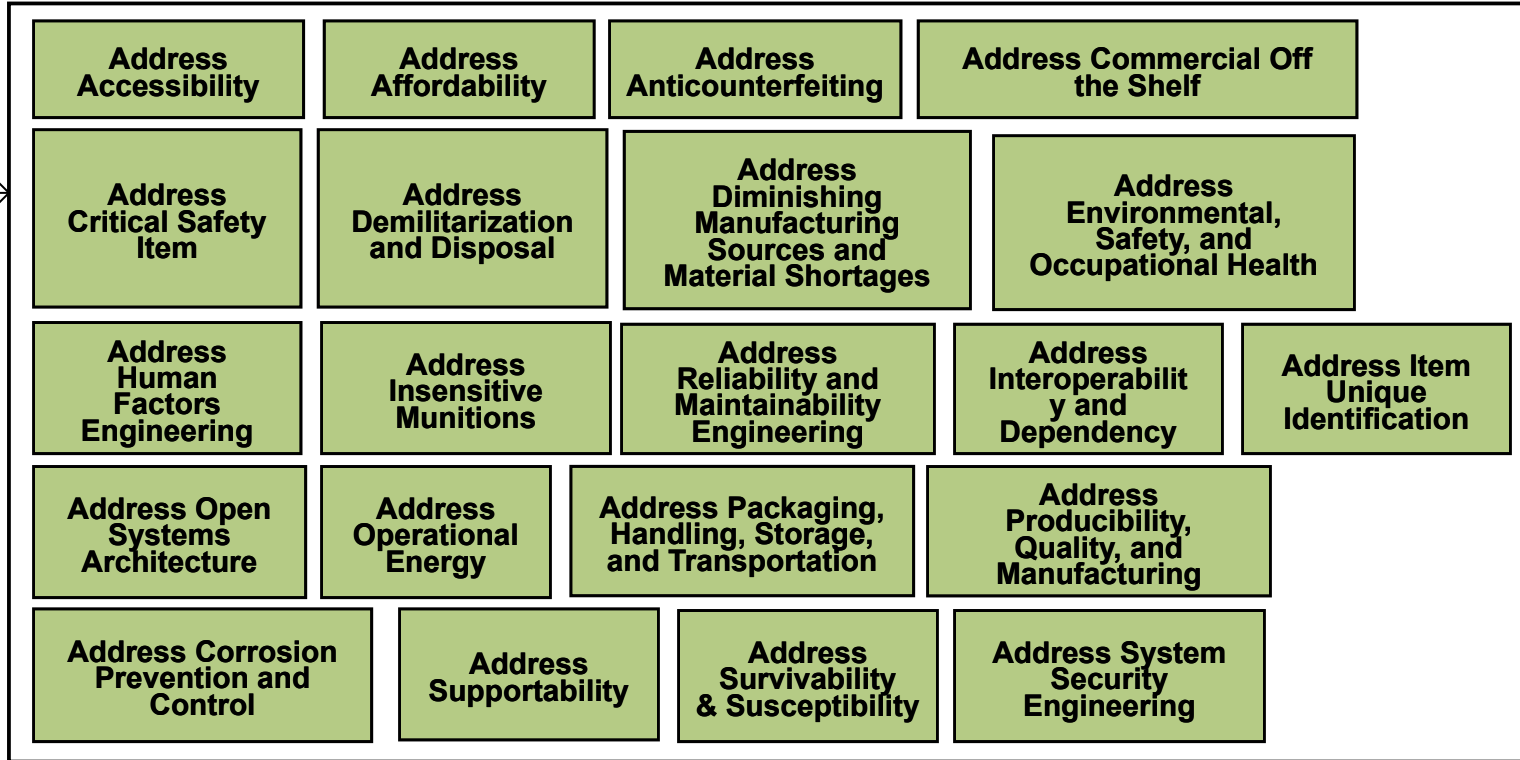

Design Considerations

Note: Program Managers are required to leverage Cloud Computing and to provide Accessibility of Electronic and IT consistent with Enclosure 11, Sections 9 & 14 of DoDI 5000.02

BACK FWD

Go Up 1 Level

Acquisition Process Model

1.5.1.2.6.4 Address Spectrum Management

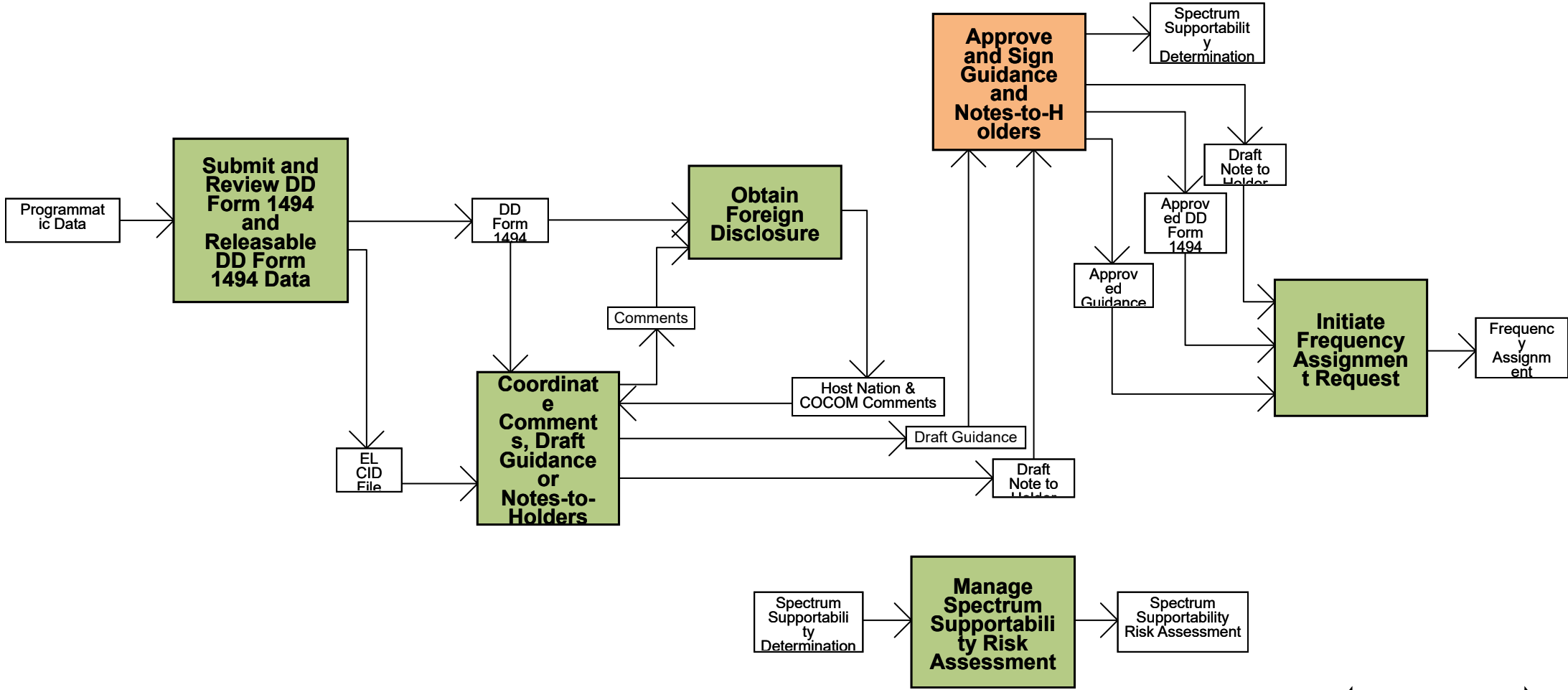

Note: The above process is executed for each of the four stages of certification: Conceptual (initial system planning has been completed), Experimental (preliminary system design has been completed), Developmental (major system design has been completed), and Operational (system development is complete). Source: AFI 17-220, Section 4.5.1.

← BACK FWD →

Go Up 1 Level

Acquisition Process Model

1.5.1.2.6.5 Address Intelligence Life Cycle Mission Data Plan

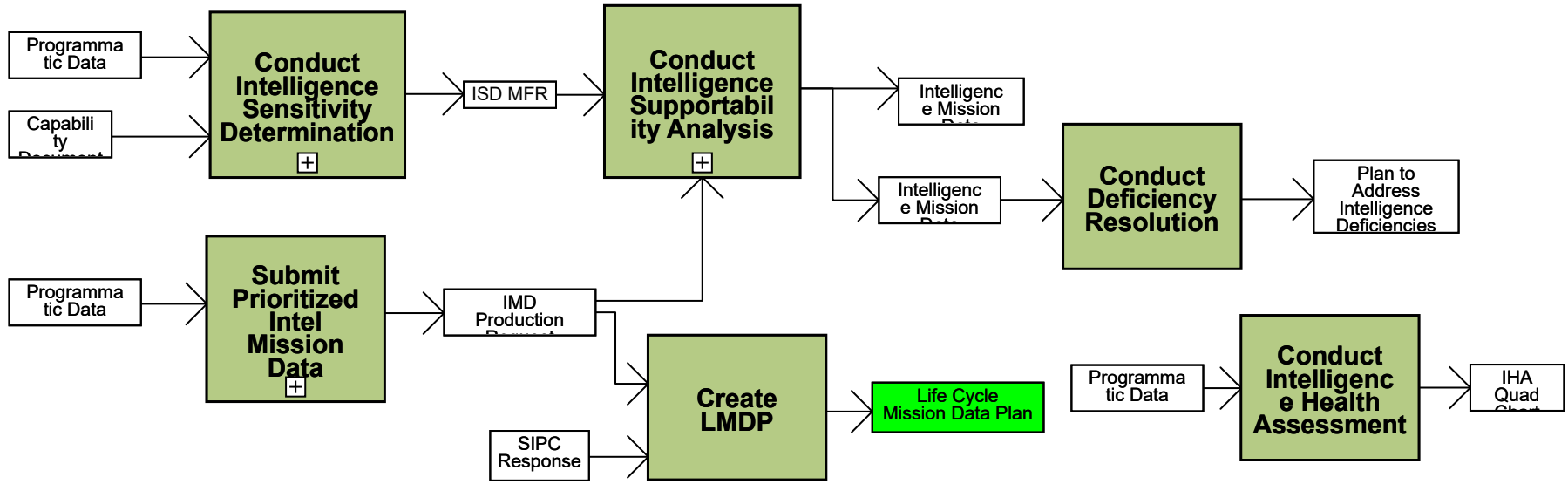

Note: The first two processes are further defined by AFLCMC Standard Processes.

BACK FWD

Go Up 1 Level

Acquisition Process Model

1.5.1.2.6.5.1 Conduct Intelligence Sensitivity Determination

AFLCMC Standard Processes

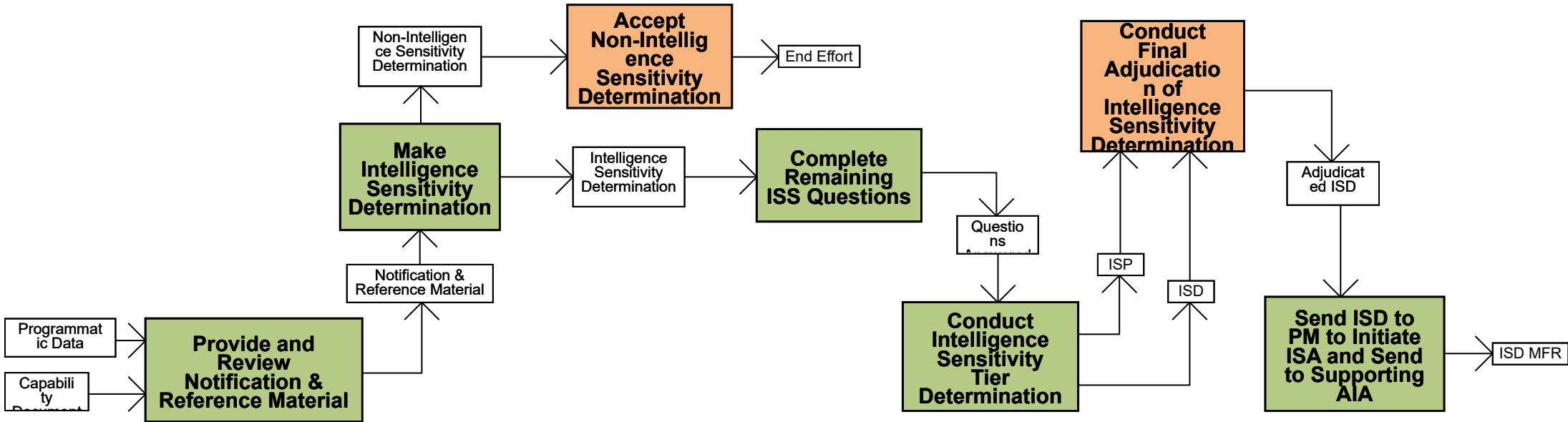

Note: This is an AFLCMC Standard Process.

FWD

Go Up 1 Level

Acquisition Process Model

1.5.1.2.6.5.2 Conduct Intelligence Supportability Analysis

AFLCMC Standard Processes

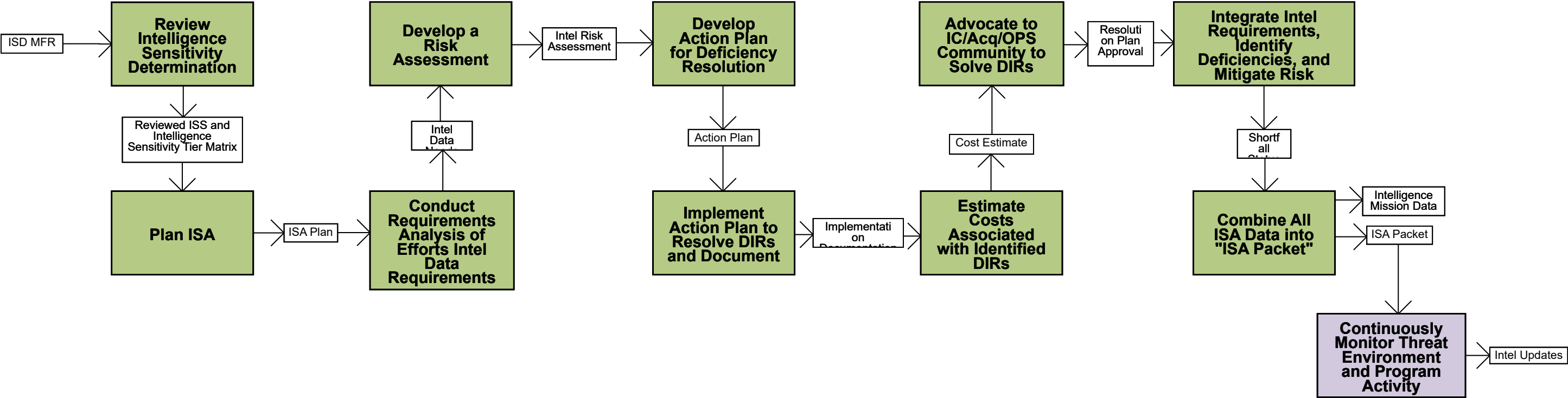

Note: This is an AFLCMC Standard Process (also includes references to AFPAM 14-111).

BACK FWD

Go Up 1 Level

Acquisition Process Model

1.5.1.2.6.5.3 Submit Prioritized Intel Mission Data

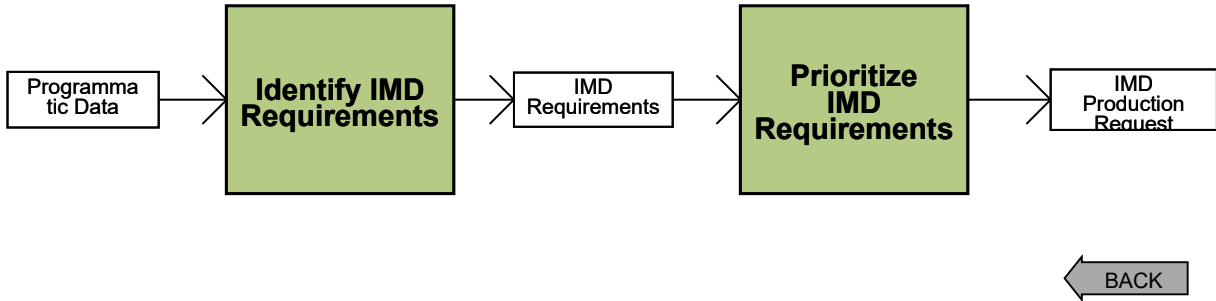

Go Up 1 Level

Acquisition Process Model

1.5.1.2.6.6 Address Standardization

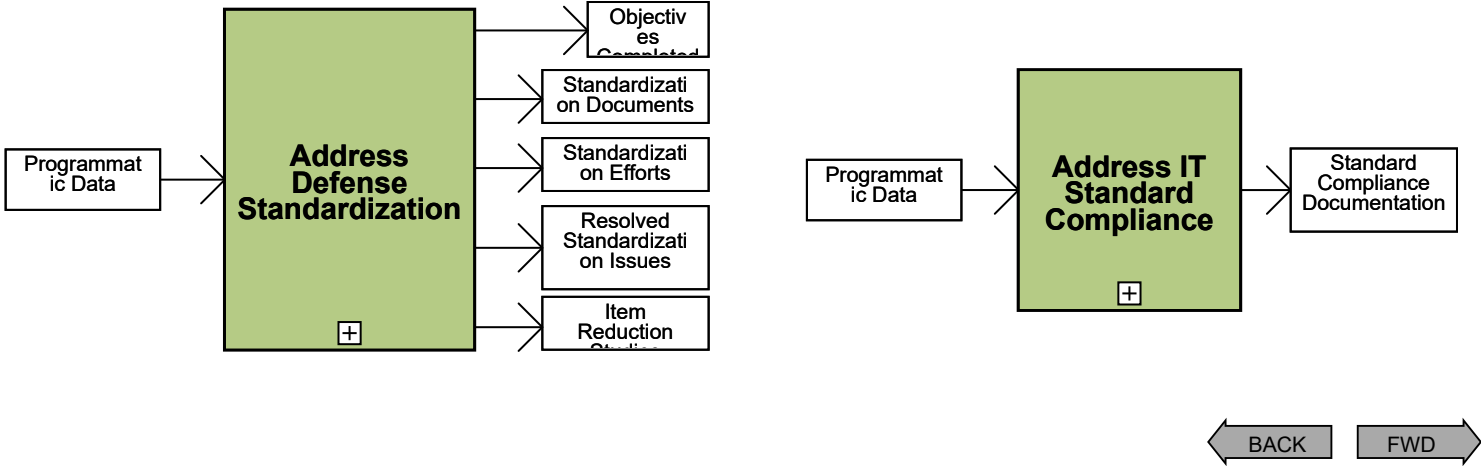

Go Up 1 Level

Acquisition Process Model

1.5.1.2.6.6.1 Address Defense Standardization

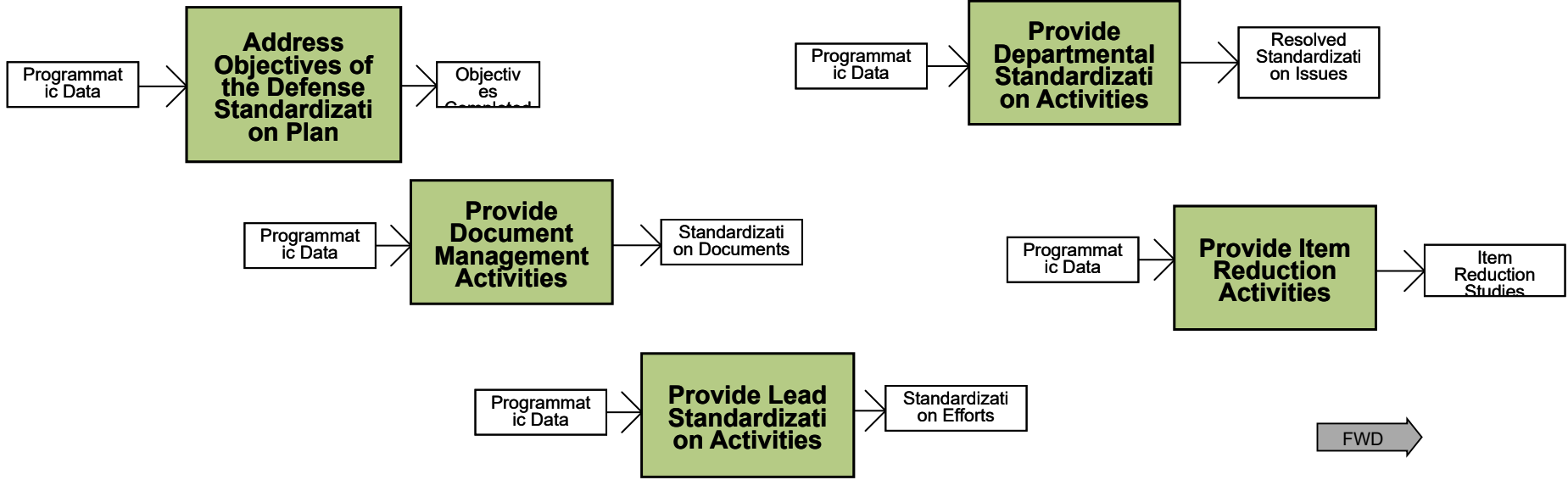

Go Up 1 Level

Acquisition Process Model

1.5.1.2.6.6.2 Address IT Standard Compliance

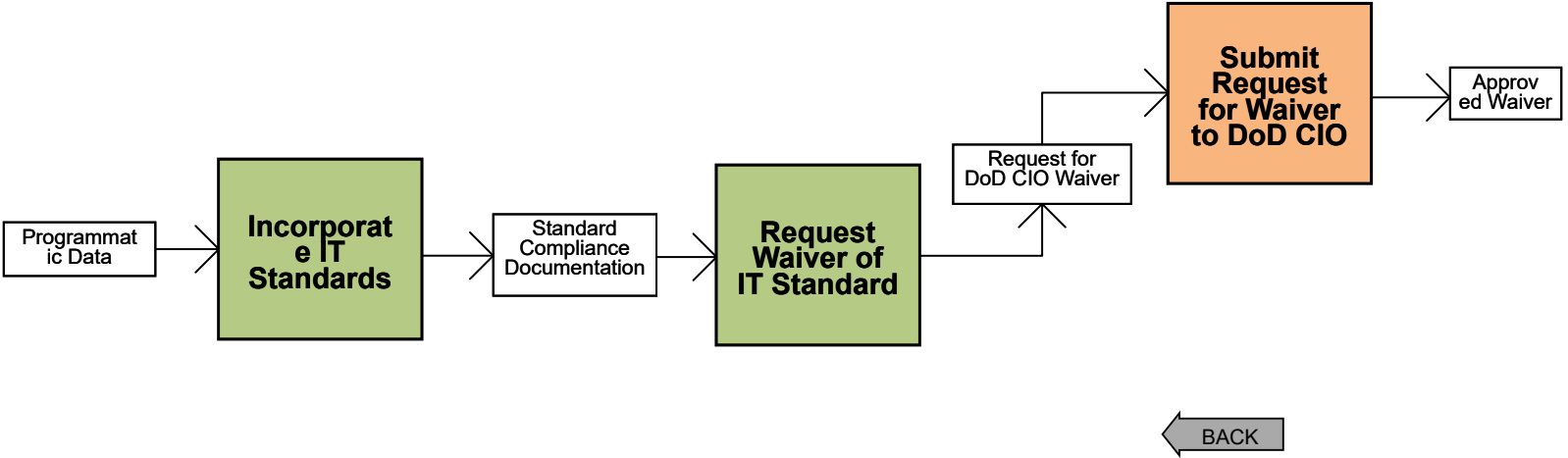

Go Up 1 Level

Acquisition Process Model

1.5.1.2.6.7 Manage Waveform Review

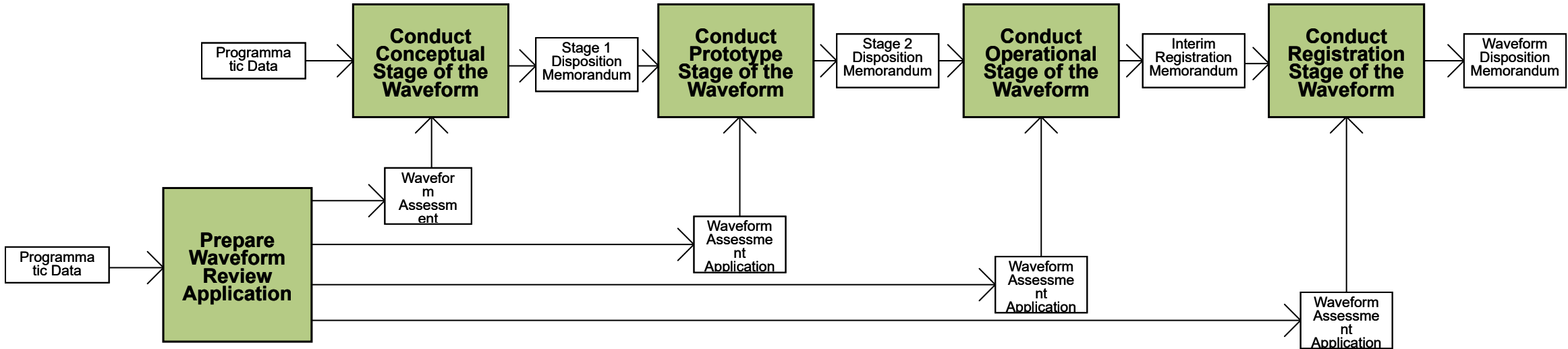

Note: The Waveform Assessment Application is updated prior to each stage. For the Conceptual Stage, it should be submitted NLT 45 days before MSA. For the Prototype Stage, it should be submitted NLT 45 days before MSB. For the Operational Stage, it should be submitted NLT 45 days before FRP/FDD.

Go Up 1 Level

Acquisition Process Model

1.5.1.2.7 Conduct Systems Engineering SoS Processes

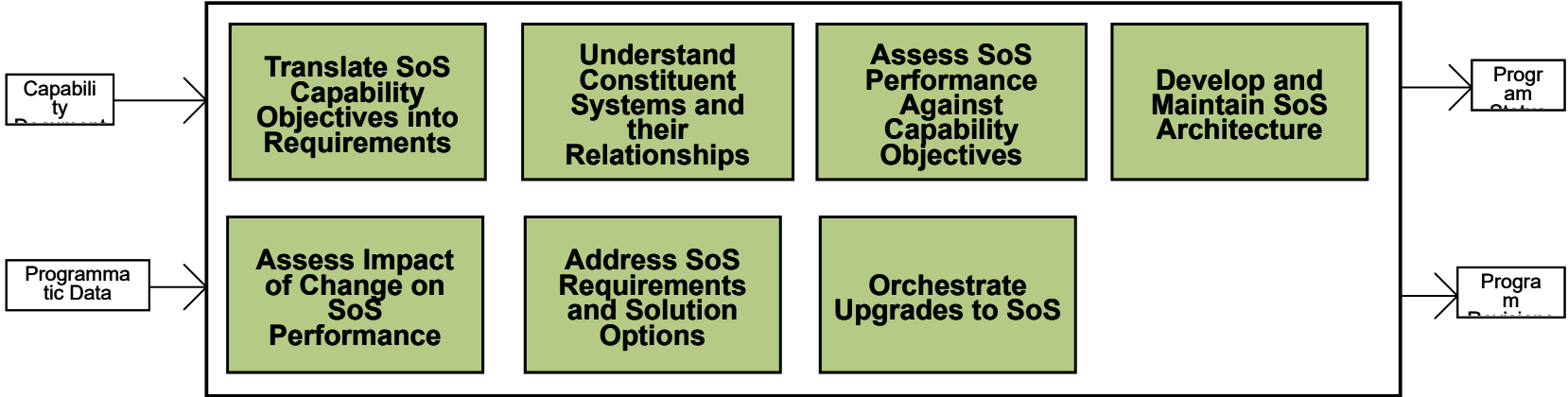

← BACK

Go Up 1 Level

Acquisition Process Model

1.5.1.3 Manage Resources

PEO View

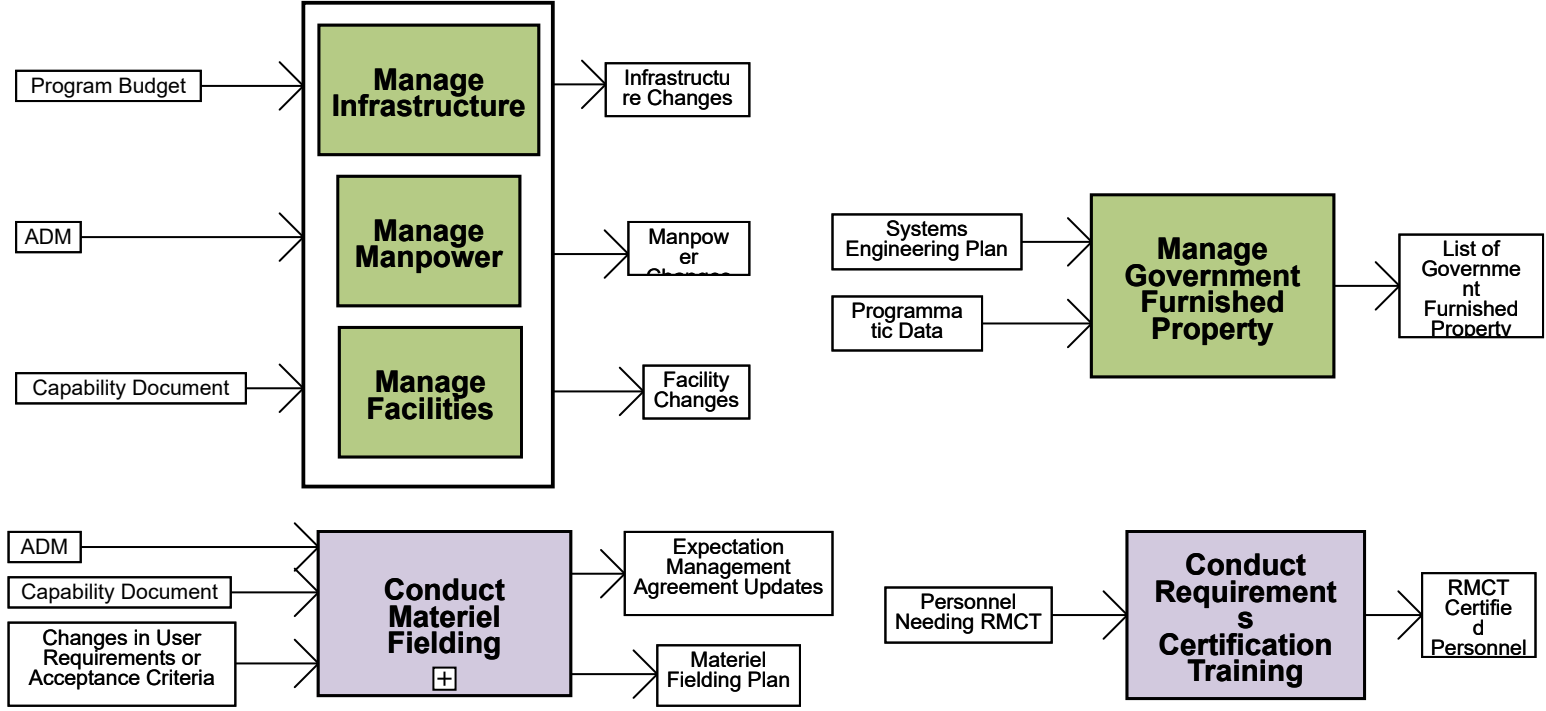

BACK FWD

Acquisition Process Model

1.5.1.3.4 Conduct Materiel Fielding

Go Up 1 Level

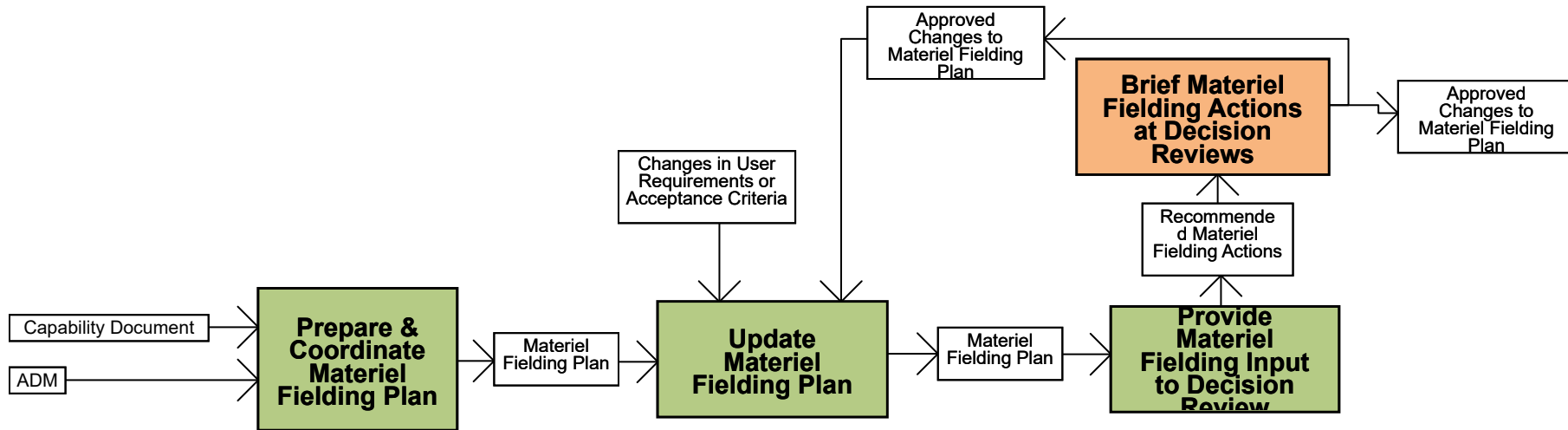

Go Up 1 Level

Acquisition Process Model

1.5.1.4 Conduct Issue Resolution

AFLCMC
Standard
Processes

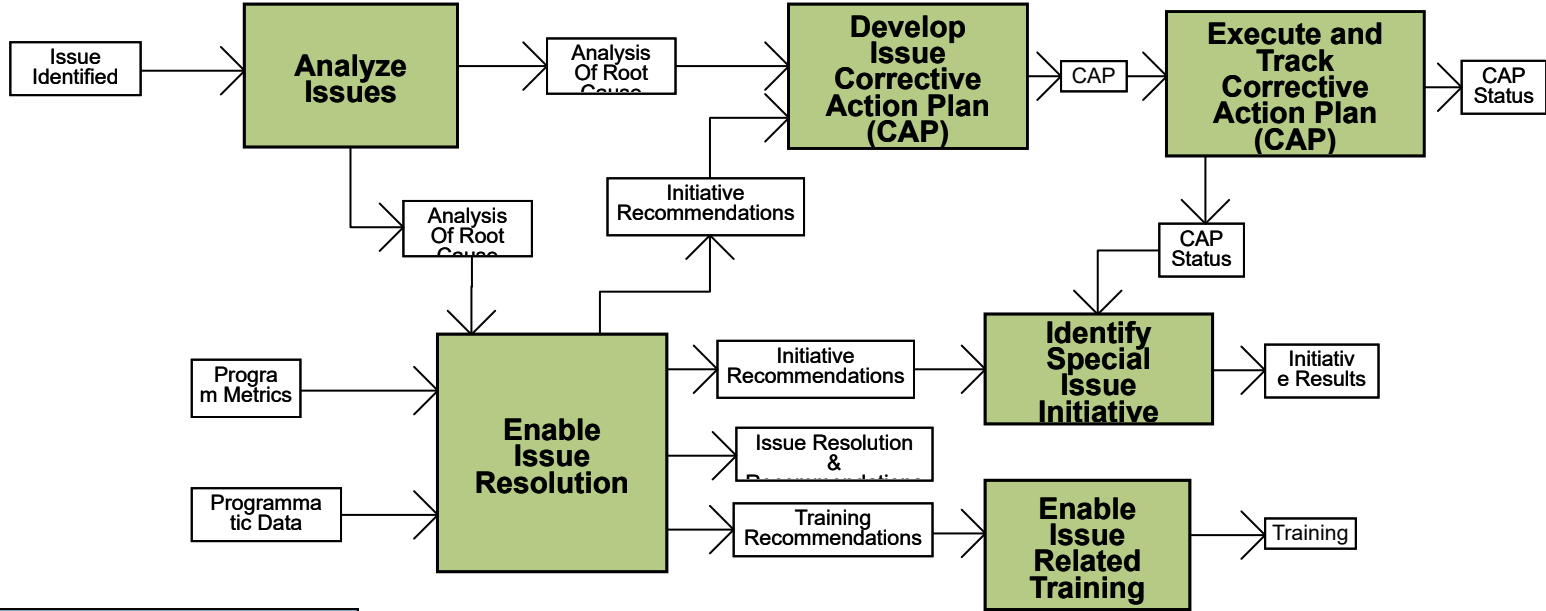

Note: The top three processes are from the AFLCMC standard processes for Risk and Issue Management.

← BACK

Go Up 1 Level

Acquisition Process Model

1.5.2 Manage Communication and Reports

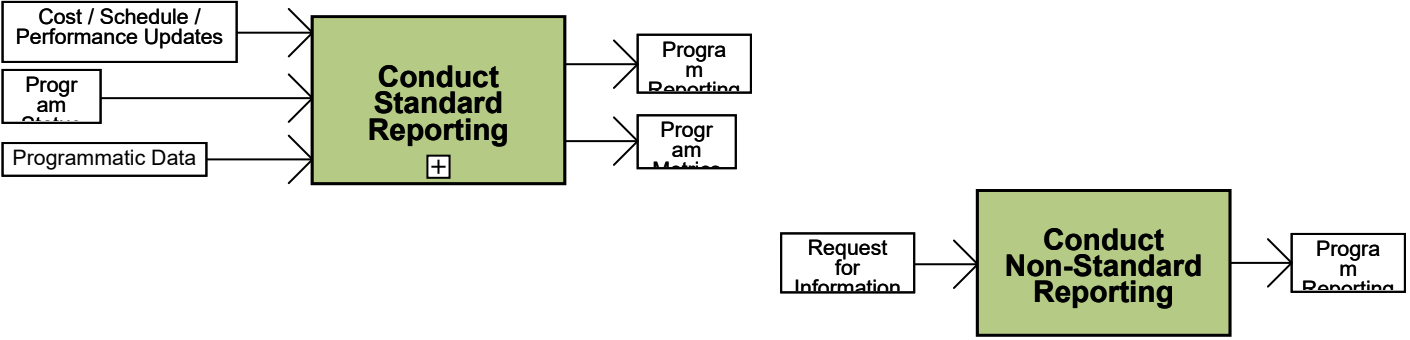

Note: For information regarding Small Business Communication click the link below:
[SB. 6 Small Business Communications](#)

← BACK FWD →

Acquisition Process Model

1.5.2.1 Conduct Standard Reporting

PEO View

Go Up 1 Level

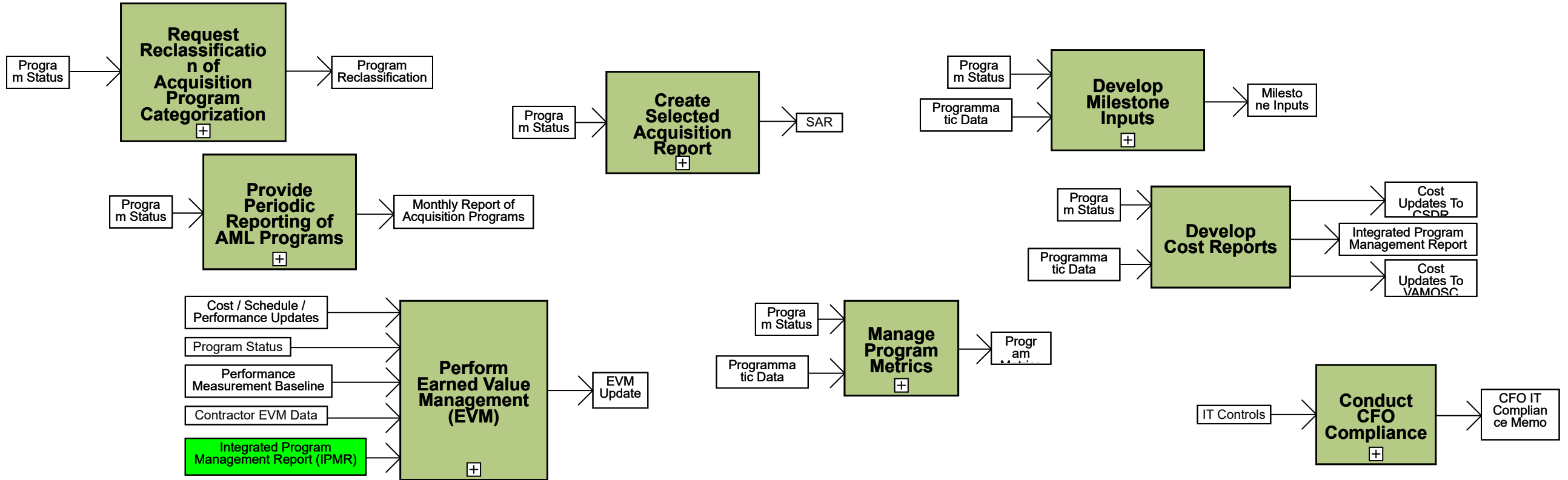

Note 1: The MDA is strongly encouraged to tailor the reporting requirements consistent with Enclosure 1, Table 2 of the DoDI 5000.02

Note 2: The purpose of program tailoring is to streamline the acquisition program to the maximum extent possible, consistent with risk, to provide new systems to operational commanders as fast as possible. DoDI 5000.02, Section 5.a.2; AFPAM 63-128, Section 14.1

Go Up 1 Level

Acquisition Process Model

1.5.2.1.1 Request Reclassification of Acquisition Program Categorization

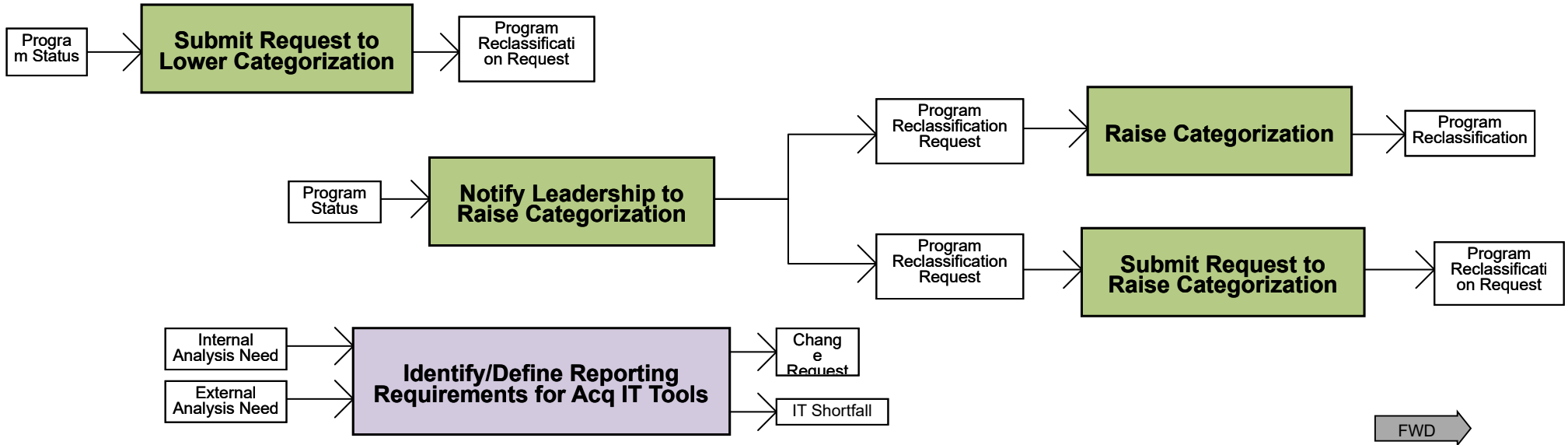

Go Up 1 Level

Acquisition Process Model

1.5.2.1.2 Provide Periodic Reporting of AML Programs

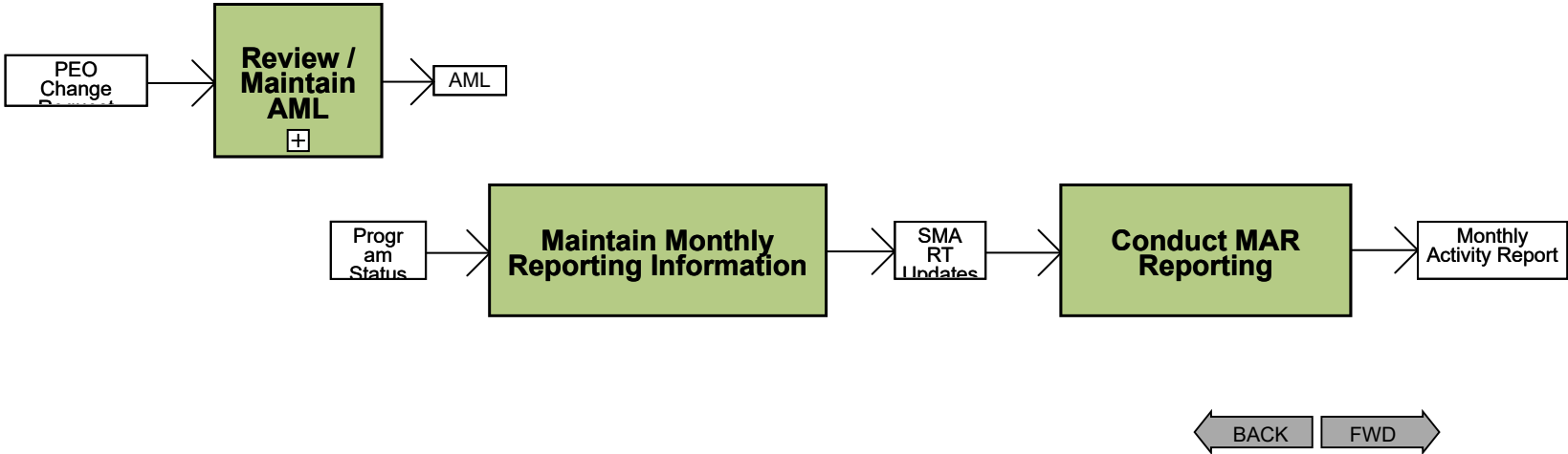

Go Up 1 Level

Acquisition Process Model

1.5.2.1.2.1 Review - Maintain AML

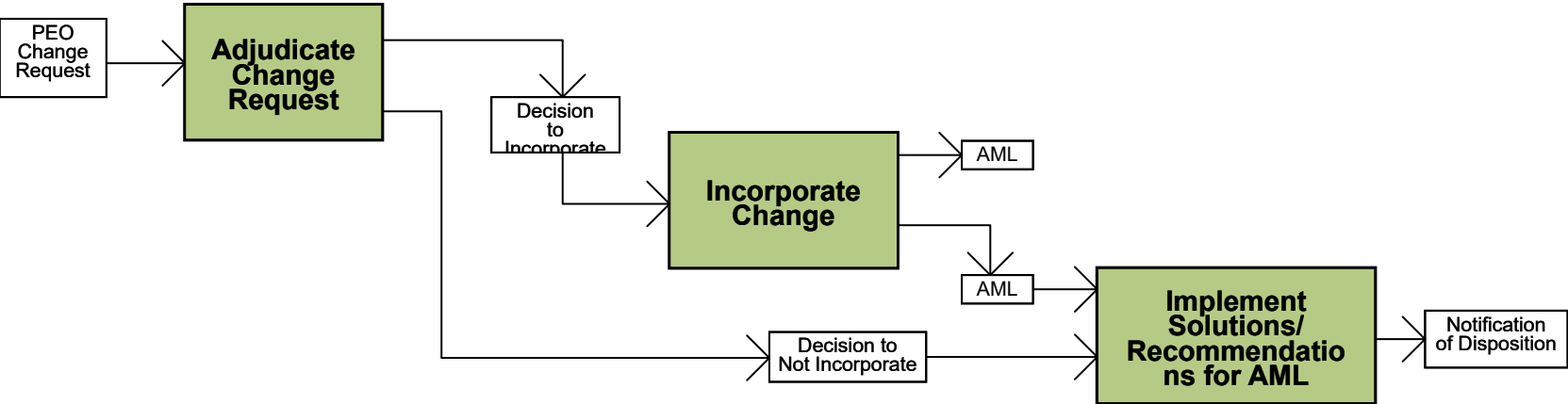

Go Up 1 Level

Acquisition Process Model

1.5.2.1.3 Create Selected Acquisition Report

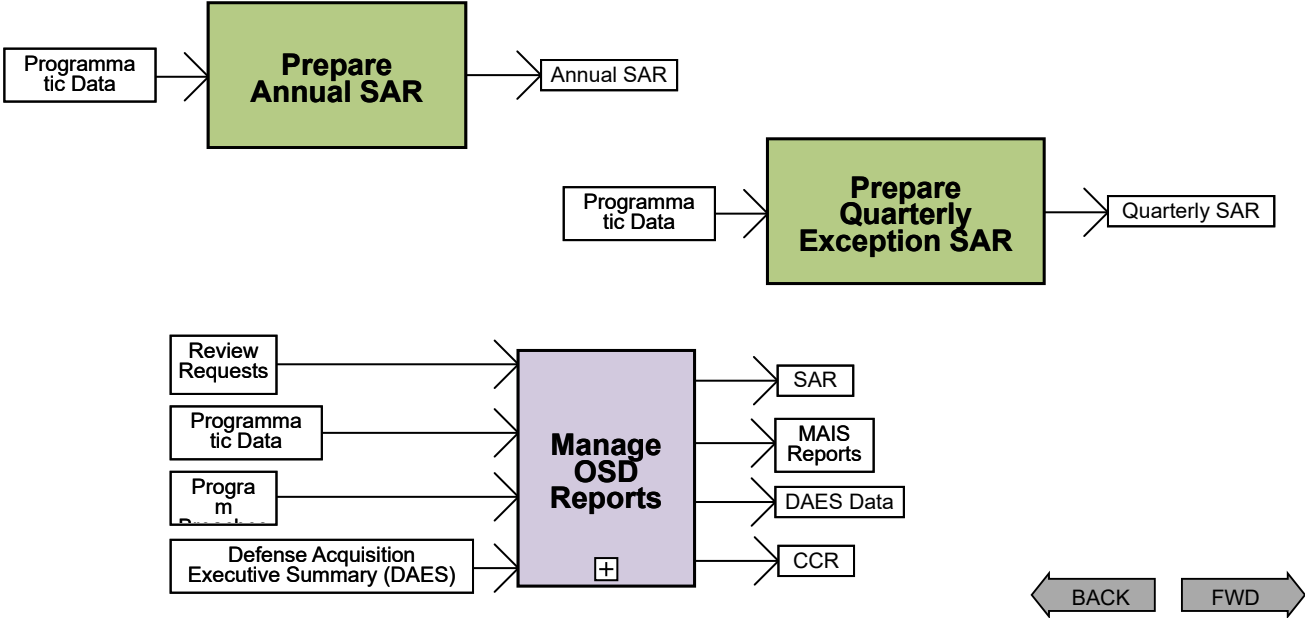

Go Up 1 Level

Acquisition Process Model

1.5.2.1.3.3 Manage OSD Reports

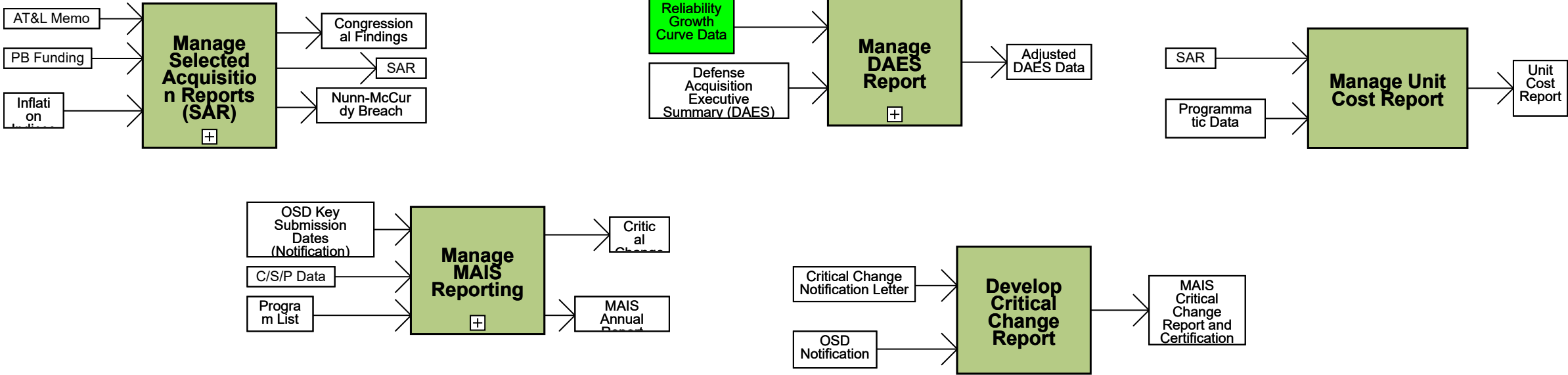

Go Up 1 Level

Acquisition Process Model

1.5.2.1.3.3.1 Manage Selected Acquisition Reports (SAR)

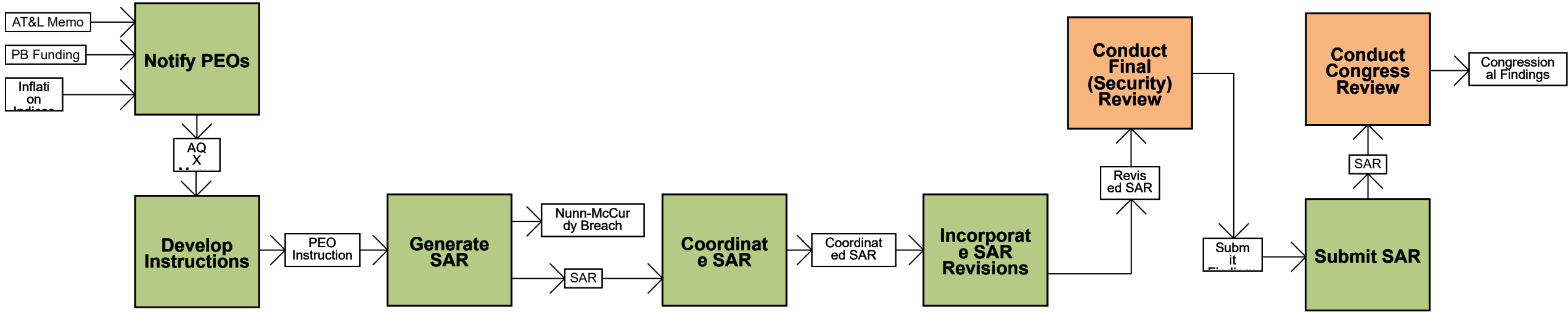

FWD

Go Up 1 Level

Acquisition Process Model

1.5.2.1.3.3.2 Manage MAIS Reporting

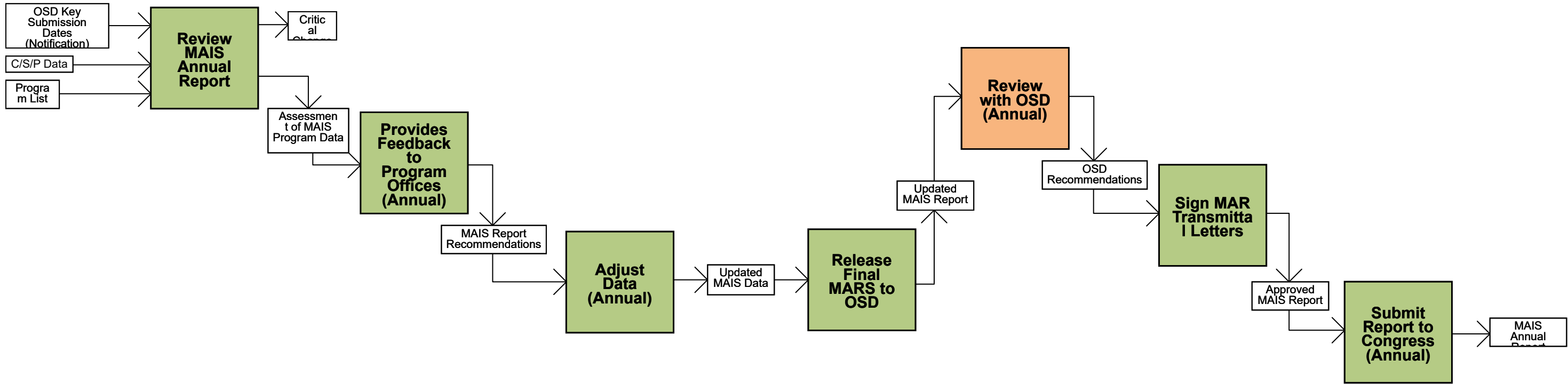

BACK

FWD

Go Up 1 Level

Acquisition Process Model

1.5.2.1.3.3.3 Manage DAES Report

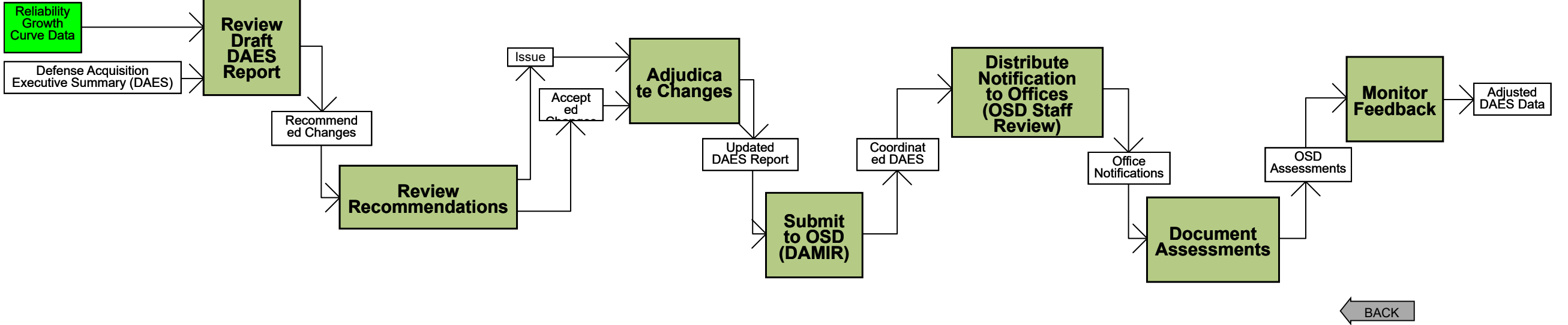

Acquisition Process Model

1.5.2.1.4 Perform Earned Value Management (EVM)

Go Up 1 Level

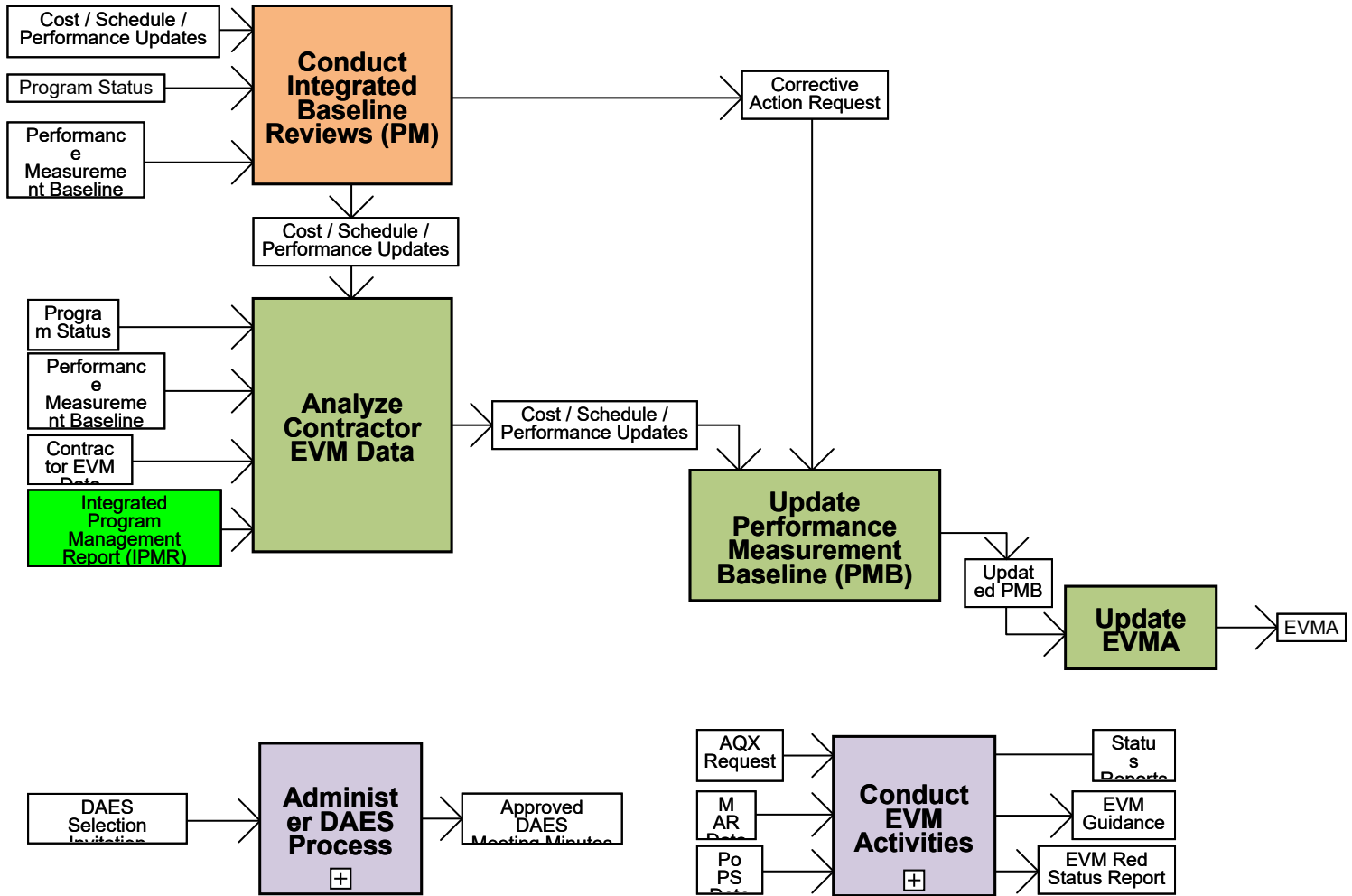

Note: DoDI 5000.02, Enclosure 2, Section 6.c provides an overview of EVM.

BACK FWD

Go Up 1 Level

Acquisition Process Model

1.5.2.1.4.5 Administer DAES Process

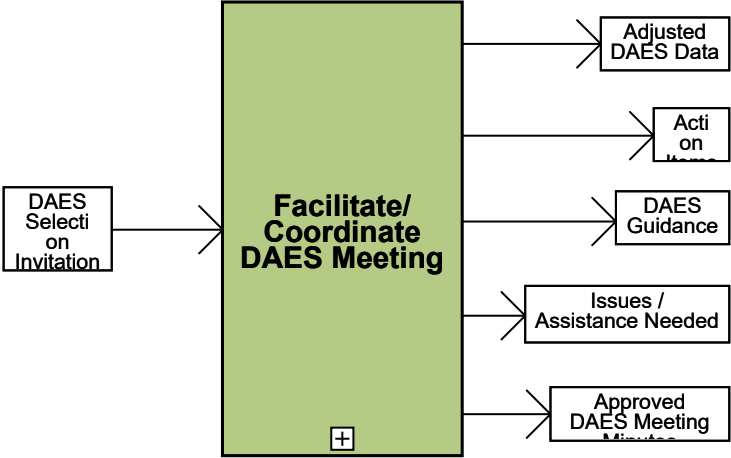

FWD

Go Up 1 Level

Acquisition Process Model

1.5.2.1.4.5.2 Facilitate - Coordinate DAES Meeting

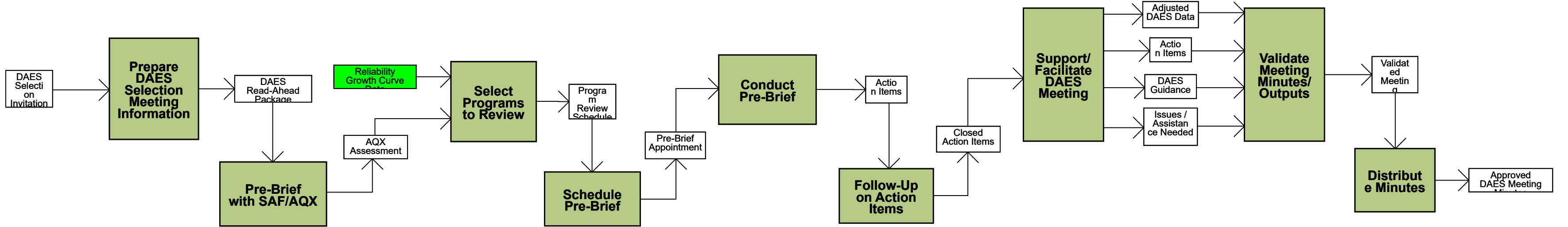

Go Up 1 Level

Acquisition Process Model

1.5.2.1.4.6 Conduct EVM Activities

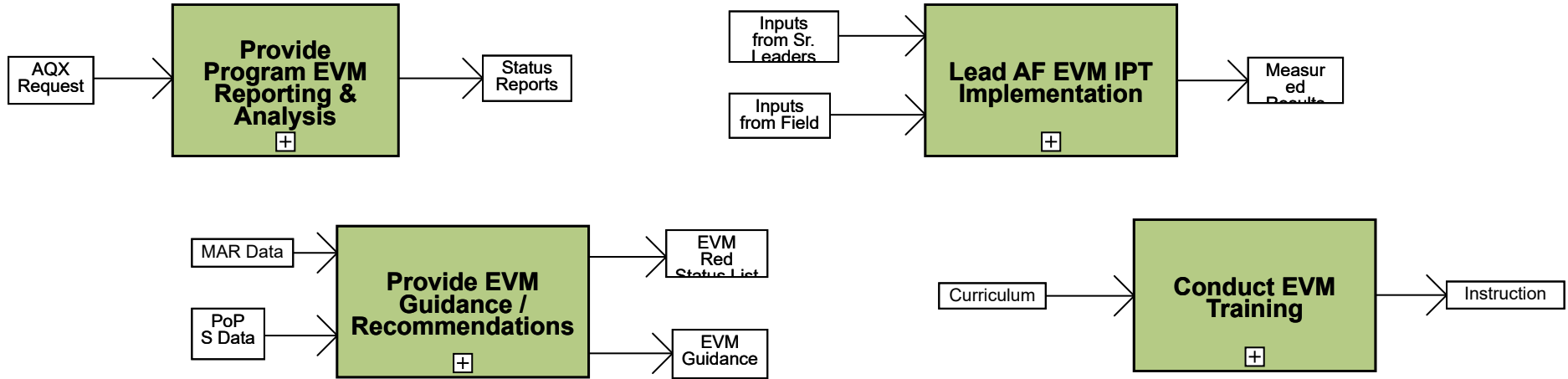

← BACK

Go Up 1 Level

Acquisition Process Model

1.5.2.1.4.6.1 Provide Program EVM Reporting and Analysis

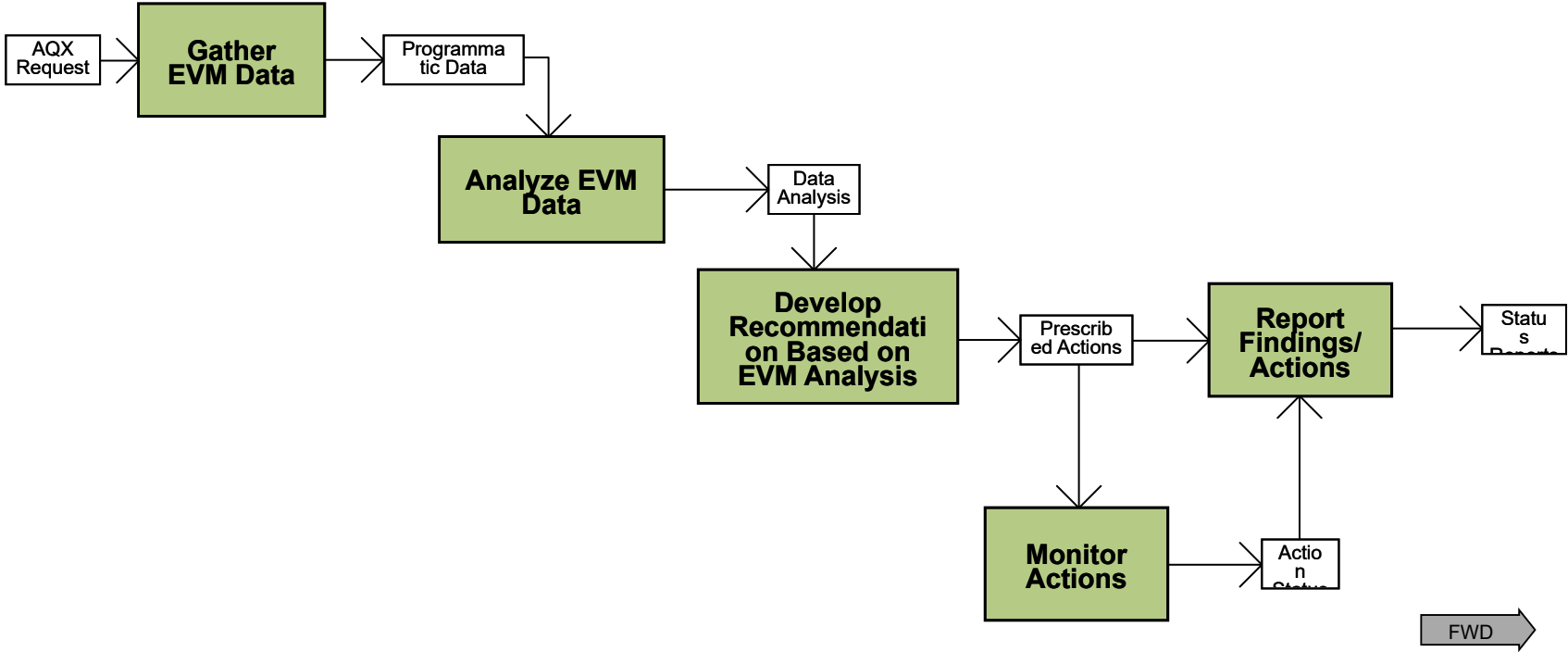

FWD

Acquisition Process Model

1.5.2.1.4.6.2 Provide EVM Guidance - Recommendations

Go Up 1 Level

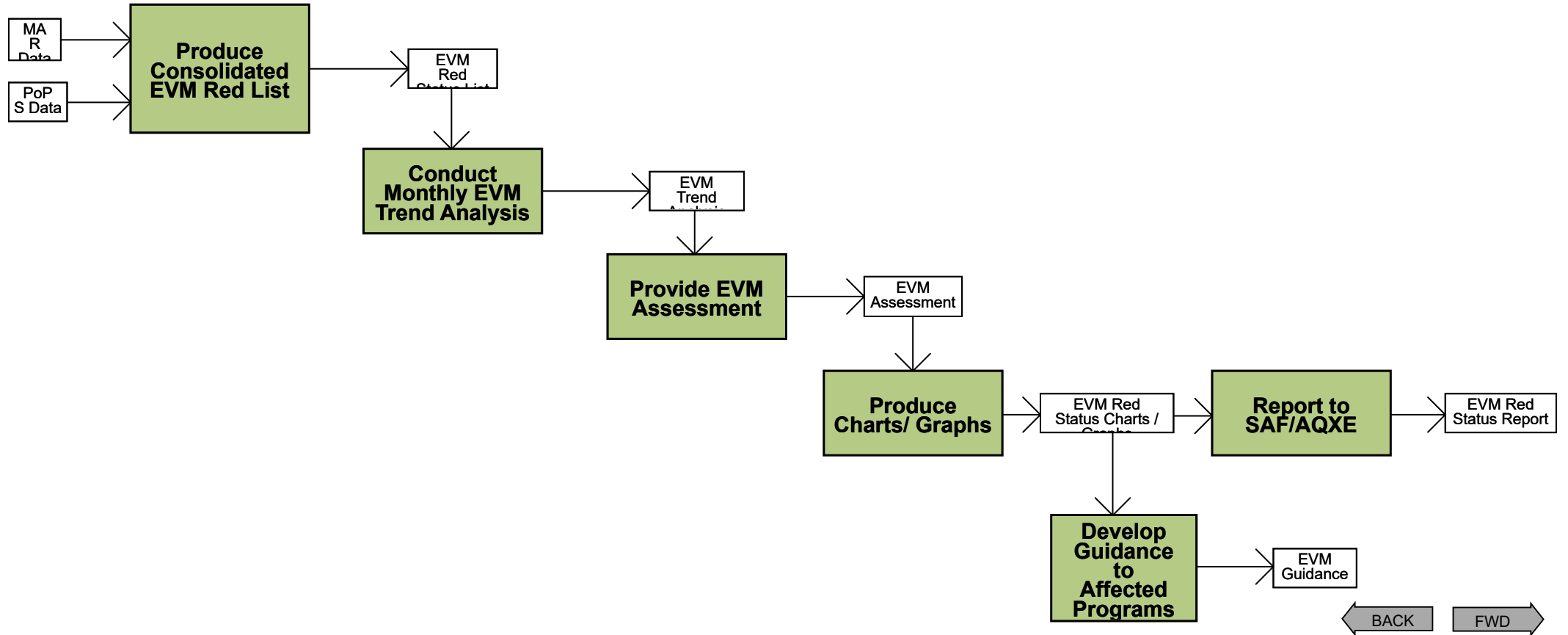

Go Up 1 Level

Acquisition Process Model

1.5.2.1.4.6.3 Lead AF EVM IPT Implementation

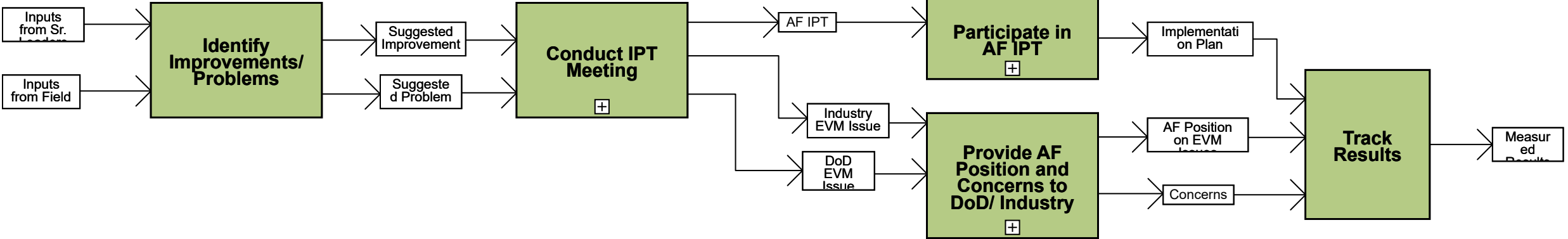

← BACK

FWD →

Go Up 1 Level

Acquisition Process Model

1.5.2.1.4.6.3.2 Conduct IPT Meeting

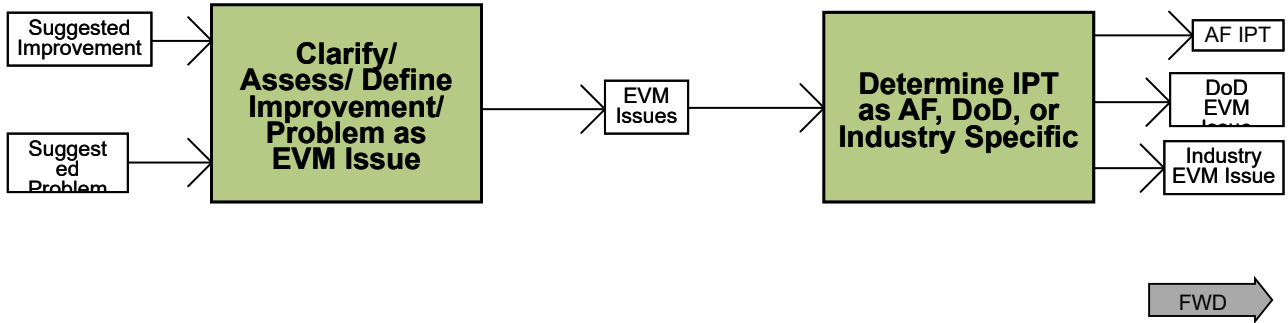

Go Up 1 Level

Acquisition Process Model

1.5.2.1.4.6.3.3 Participate in AF IPT

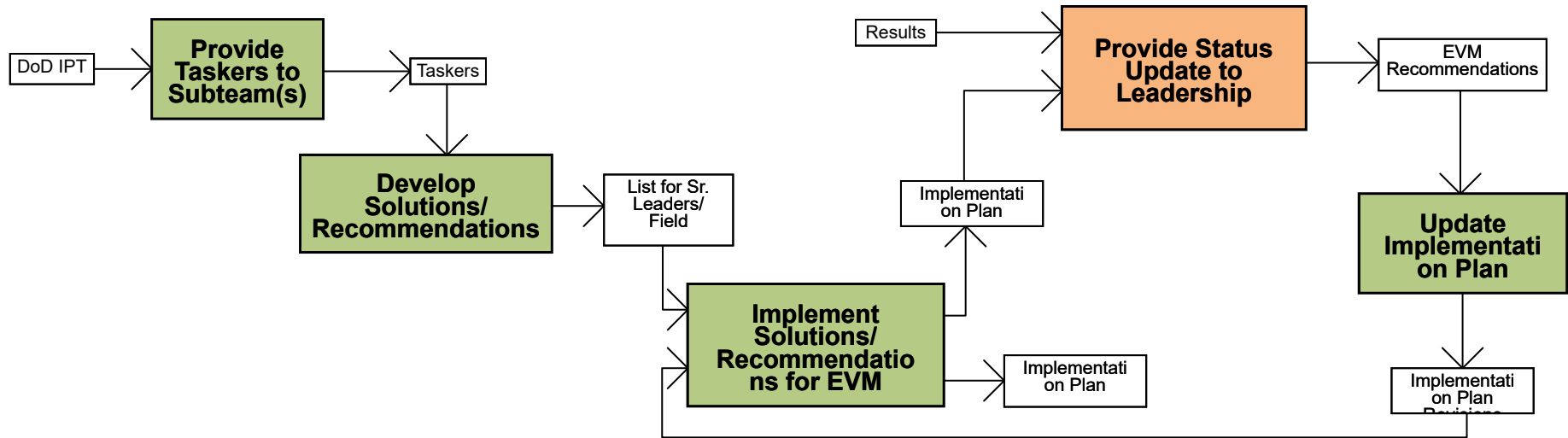

BACK FWD

Go Up 1 Level

Acquisition Process Model

1.5.2.1.4.6.3.4 Provide AF Position and Concerns to DoD - Industry

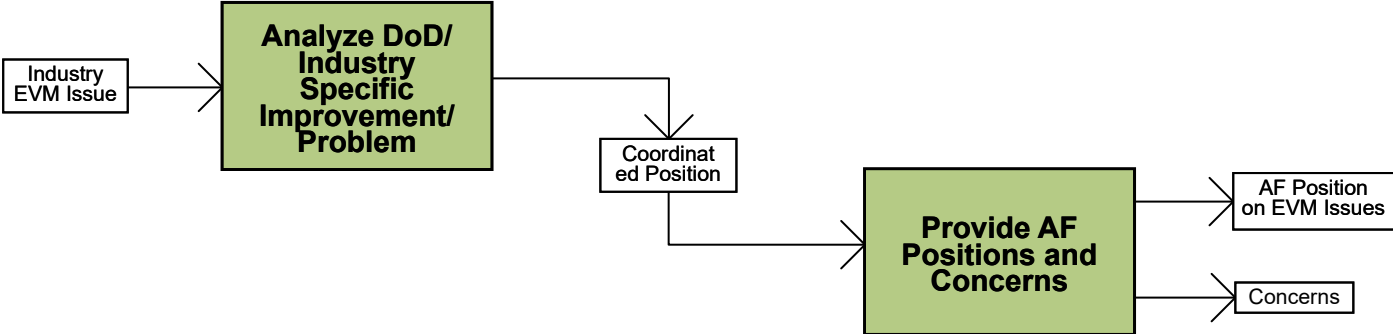

← BACK

Go Up 1 Level

Acquisition Process Model

1.5.2.1.4.6.4 Conduct EVM Training

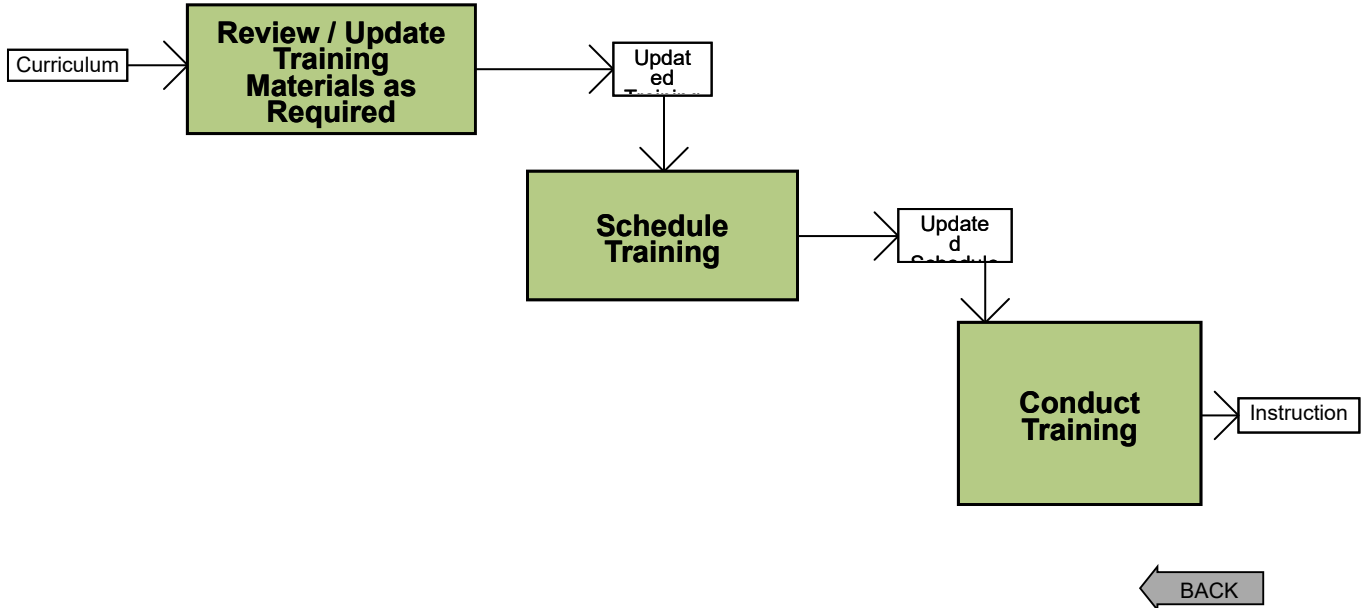

Acquisition Process Model

1.5.2.1.5 Develop Milestone Inputs

Go Up 1 Level

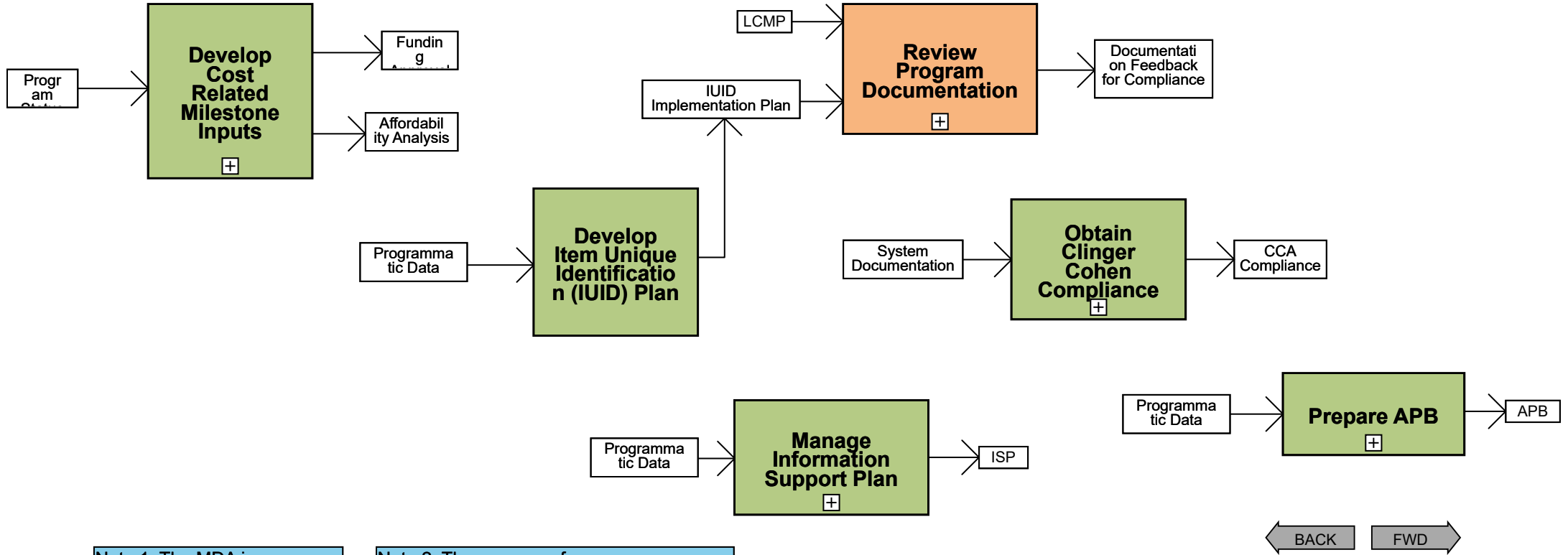

BACK FWD

Note 1: The MDA is strongly encouraged to tailor the reporting requirements consistent with Enclosure 1, Table 2 of the DoDI 5000.02

Note 2: The purpose of program tailoring is to streamline the acquisition program to the maximum extent possible, consistent with risk, to provide new systems to operational commanders as fast as possible. DoDI 5000.02, Section 5.a.2; AFPAM 63-128, Section 14.1

Go Up 1 Level

Acquisition Process Model

1.5.2.1.5.1 Develop Cost Related Milestone Inputs

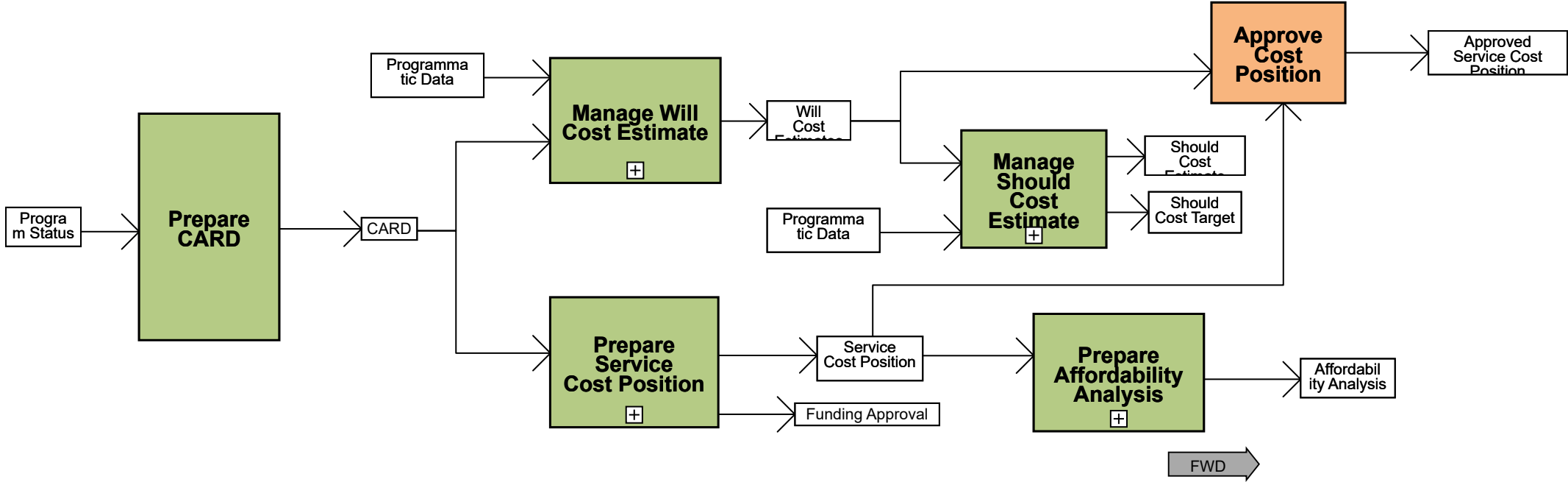

Go Up 1 Level

Acquisition Process Model

1.5.2.1.5.1.2 Manage Will Cost Estimate

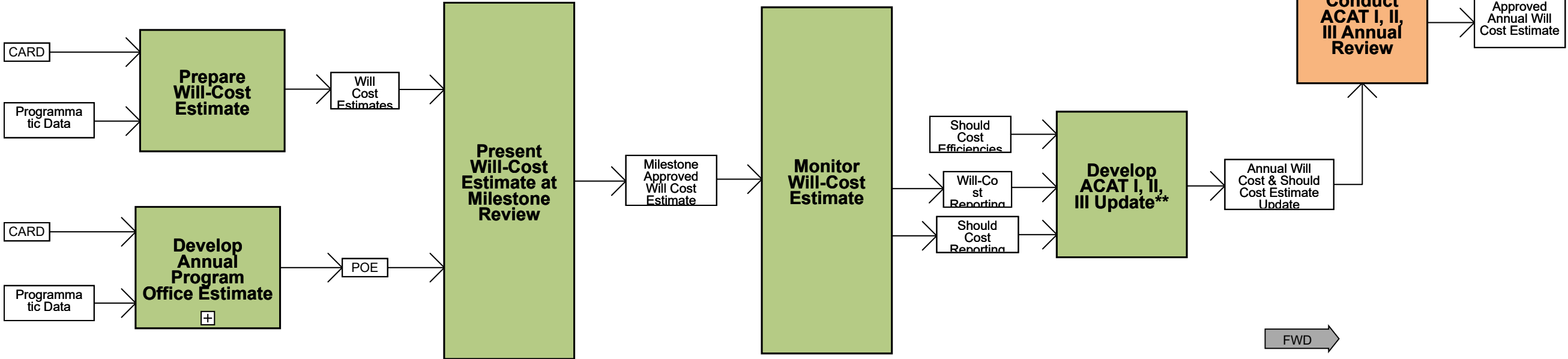

Note: This annual update reporting requirement may be waived (given appropriate justification) by the reviewing organization

Go Up 1 Level

Acquisition Process Model

1.5.2.1.5.1.2.1 Develop Annual Program Office Estimate

AFLCMC Standard Processes

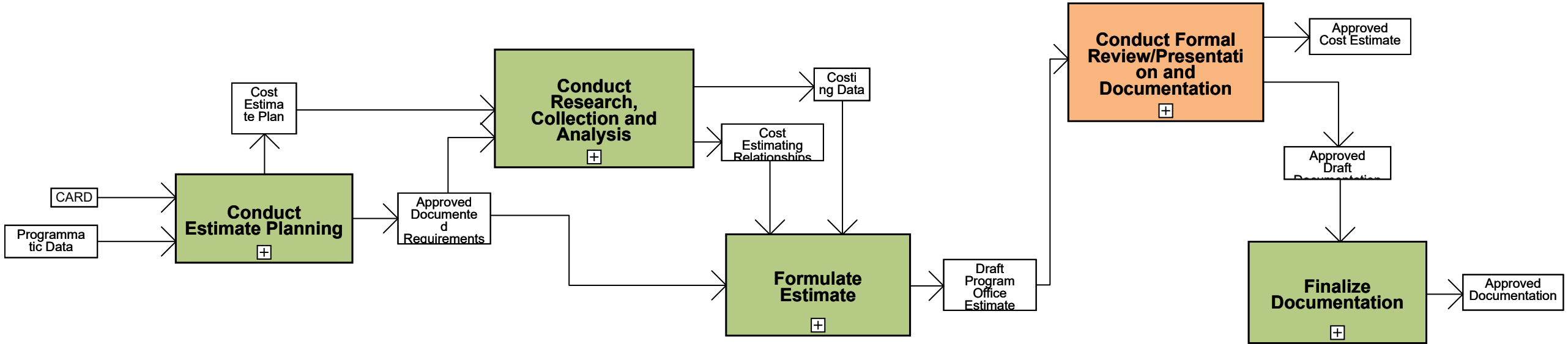

Note: This is an AFLCMC Standard Process.

Go Up 1 Level

Acquisition Process Model

1.5.2.1.5.1.2.1.1 Conduct Estimate Planning

AFLCMC
Standard
Processes

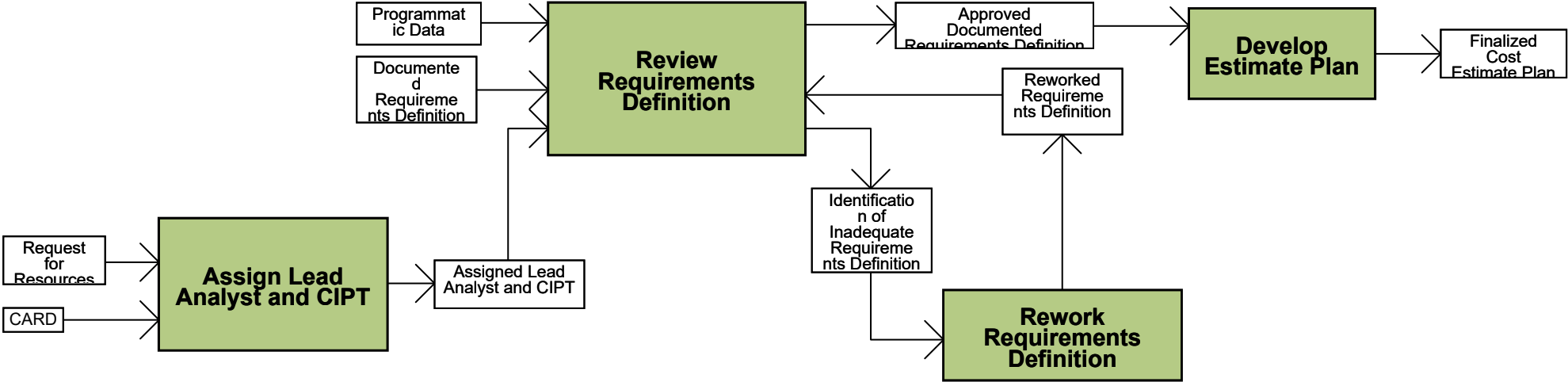

Note: This is an
AFLCMC
Standard Process.

FWD →

Go Up 1 Level

Acquisition Process Model

1.5.2.1.5.1.2.1.2 Conduct Research, Collection, and Analysis

AFLCMC Standard Processes



Note: This is an AFLCMC Standard Process.

Go Up 1 Level

Acquisition Process Model

1.5.2.1.5.1.2.1.3 Formulate Estimate

AFLCMC
Standard
Processes

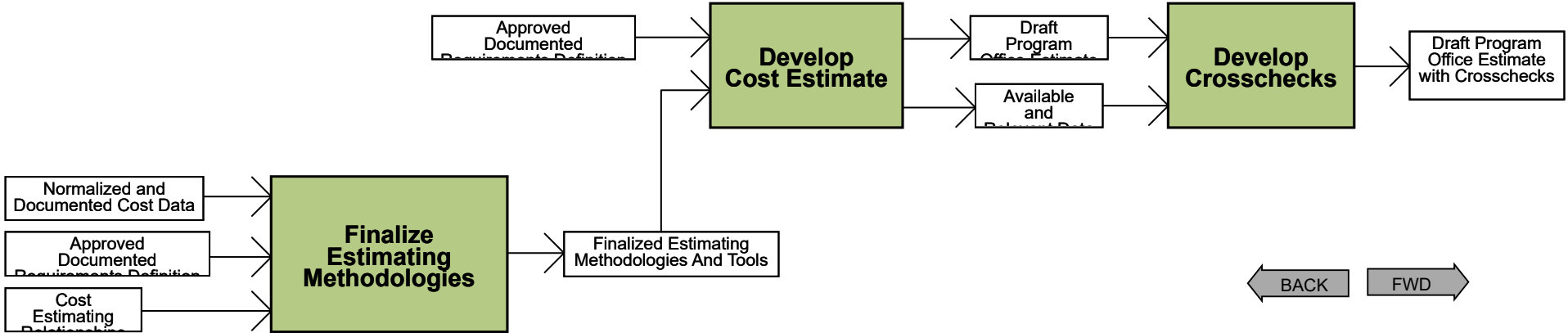

Note: This is an AFLCMC Standard Process.

Acquisition Process Model

1.5.2.1.5.1.2.1.4 Conduct Formal Review (Presentation) and Documentation

Go Up 1 Level

AFLCMC
Standard
Processes

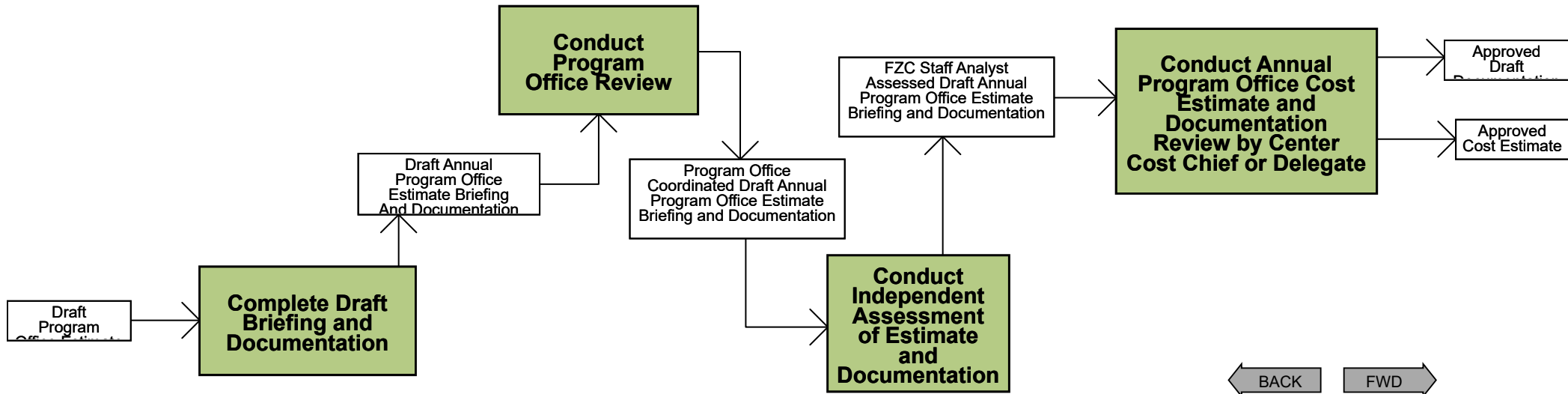

Note: This is an
AFLCMC
Standard Process.

BACK

FWD

Go Up 1 Level

Acquisition Process Model

1.5.2.1.5.1.2.1.5 Finalize Documentation

AFLCMC
Standard
Processes

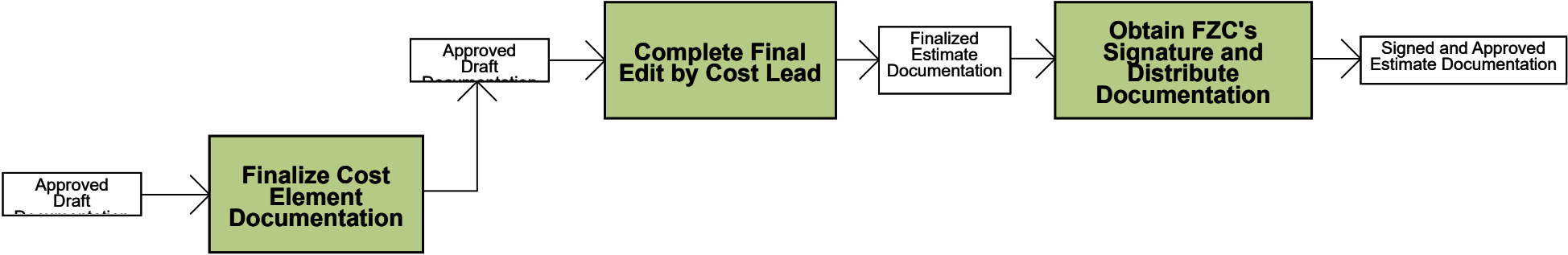

Note: This is an AFLCMC Standard Process.

← BACK

Acquisition Process Model

1.5.2.1.5.1.4 Prepare Service Cost Position

Go Up 1 Level

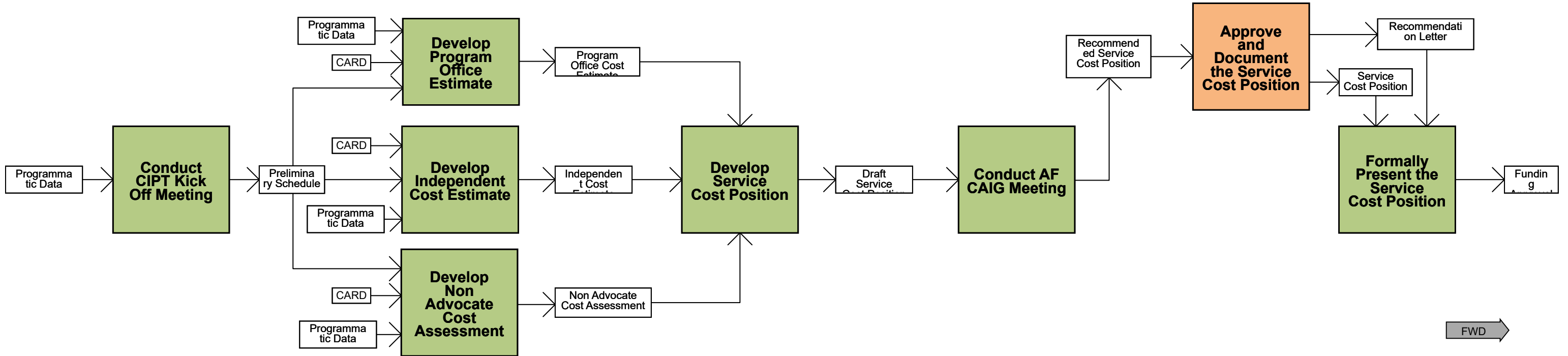

Note: DCAPE is required by statute to state the confidence level used in establishing the ICE, the rationale for selecting the confidence level, and ensure that the confidence level provides a high degree of confidence that the program can be completed without the need for significant adjustment to program budgets.

Go Up 1 Level

Acquisition Process Model

1.5.2.1.5.1.5 Prepare Affordability Analysis

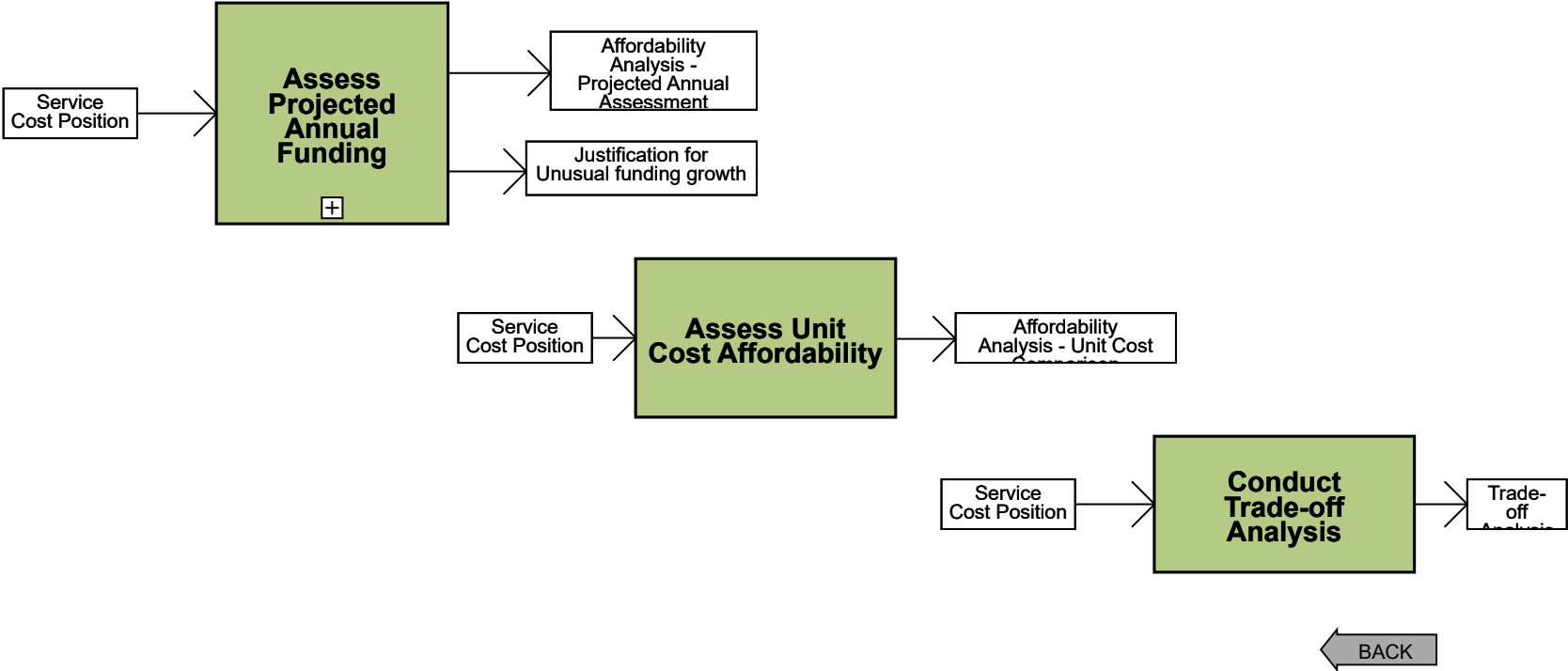

Go Up 1 Level

Acquisition Process Model

1.5.2.1.5.1.5.1 Assess Projected Annual Funding

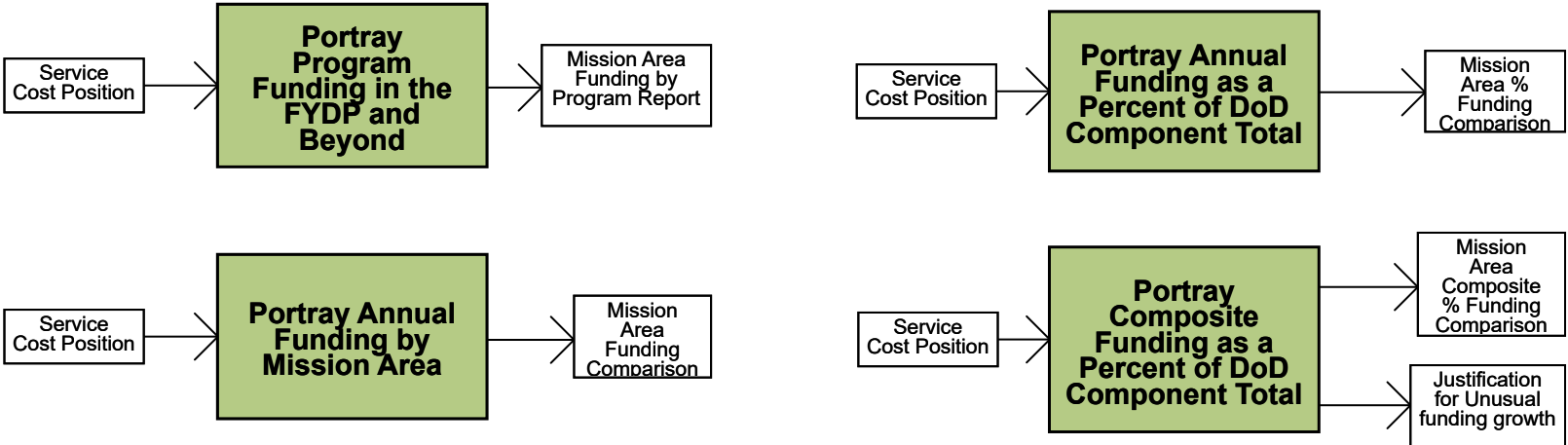

Go Up 1 Level

Acquisition Process Model

1.5.2.1.5.1.6 Manage Should Cost Estimate

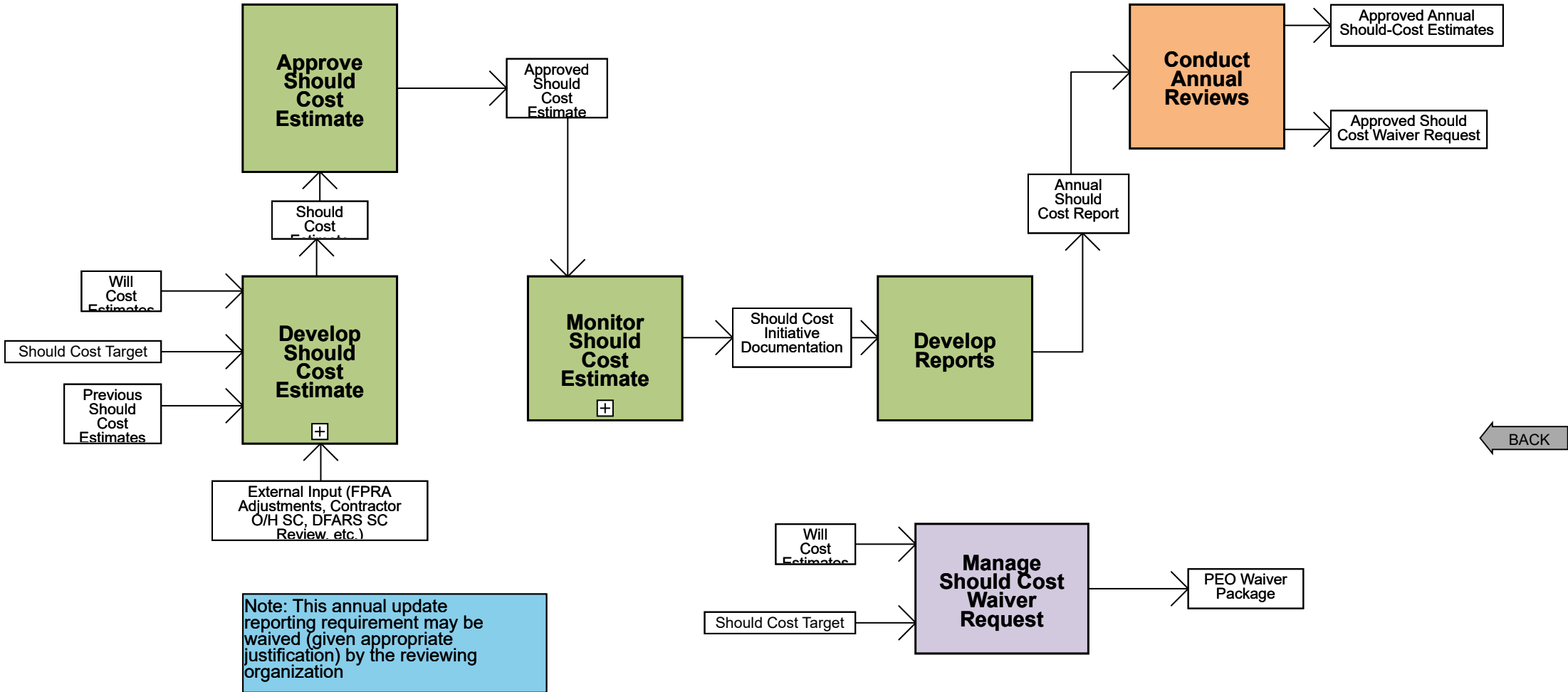

Acquisition Process Model

1.5.2.1.5.1.6.1 Develop Should Cost Estimate

Go Up 1 Level

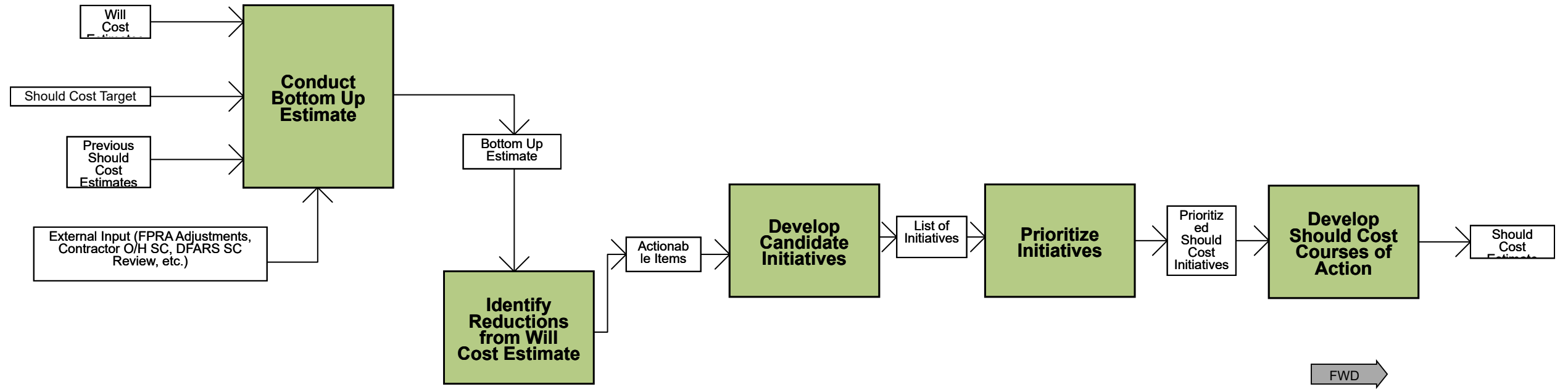

Go Up 1 Level

Acquisition Process Model

1.5.2.1.5.1.6.6 Monitor Should Cost Estimate

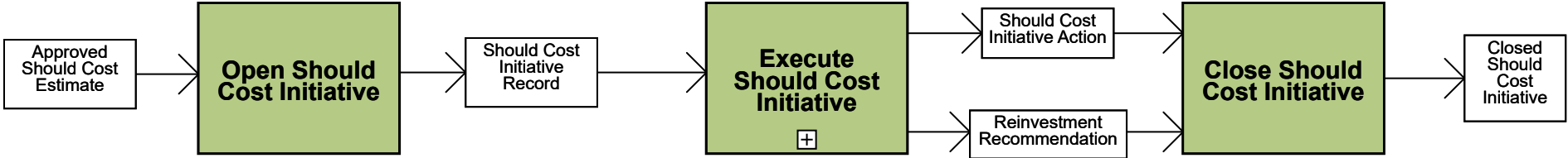

← BACK

Go Up 1 Level

Acquisition Process Model

1.5.2.1.5.1.6.6.2 Manage the Program and Monitor Initiatives

AFLCMC Standard Processes

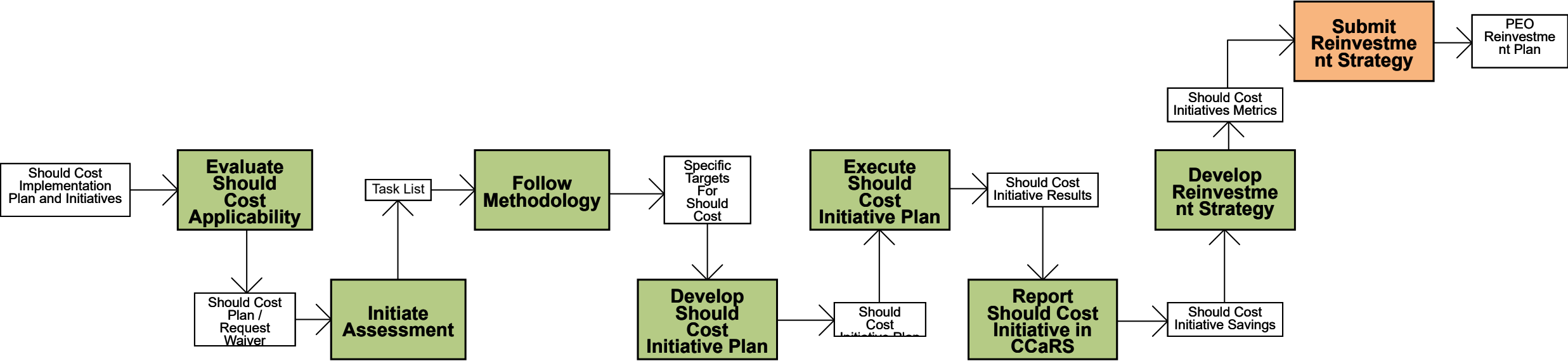

Note: This is an AFLCMC Standard Process

Go Up 1 Level

Acquisition Process Model

1.5.2.1.5.2 Review Program Documentation

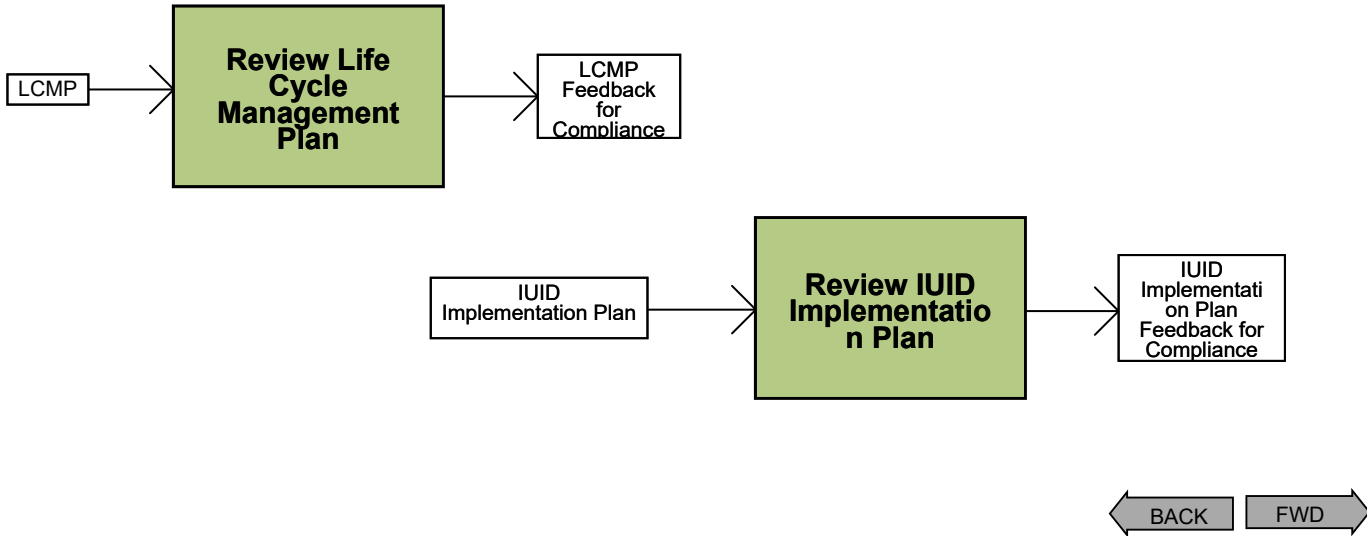

Go Up 1 Level

Acquisition Process Model

1.5.2.1.5.3 Obtain Clinger Cohen Compliance

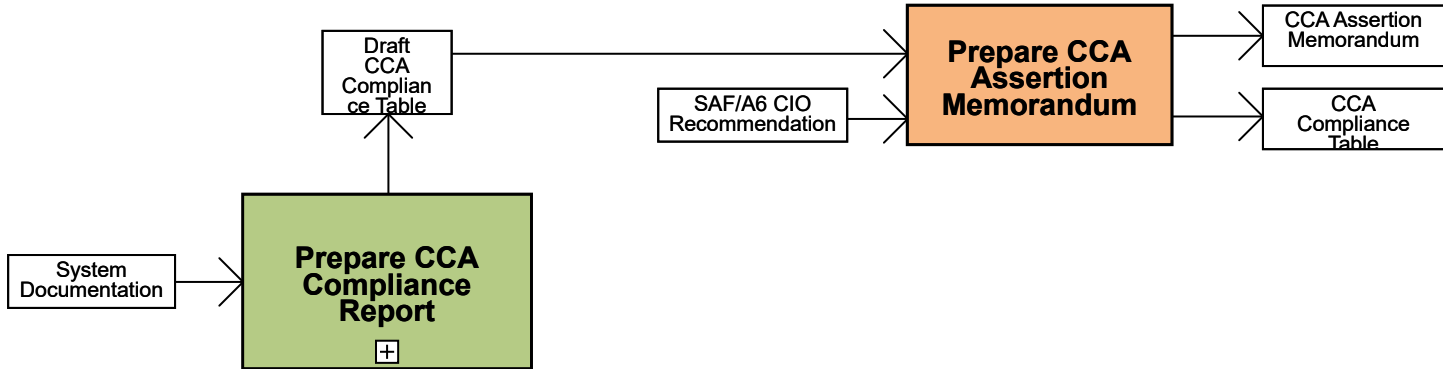

Note: DoDI 5000.02 (Enclosure 11 Section 4) requires a Post Implementation Review (PIR). The process for performing a PIR is outlined in 1.4.2.4. [Click here to view.](#)

BACK FWD

Go Up 1 Level

Acquisition Process Model

1.5.2.1.5.3.1 Prepare CCA Compliance Report

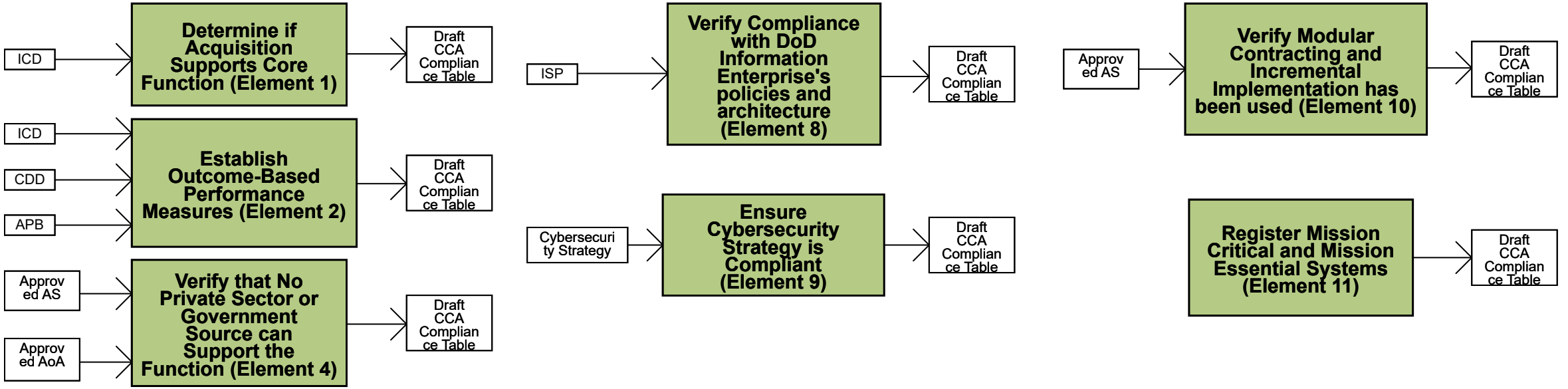

Note: The remaining four elements are depicted elsewhere in the APM. Element 3 (Redesign the processes) is in 1.5.4, Element 5 (Conduct an AoA) is in 1.3.2.3, Element 6 (Conduct an economic analysis) is in 1.3.2.3.4 & 1.5.2.1.5.1, and Element 7 (Develop measures and accountability) is in 1.5.1.1 & 1.5.2.1.

Go Up 1 Level

Acquisition Process Model

1.5.2.1.5.4 Manage Information Support Plan

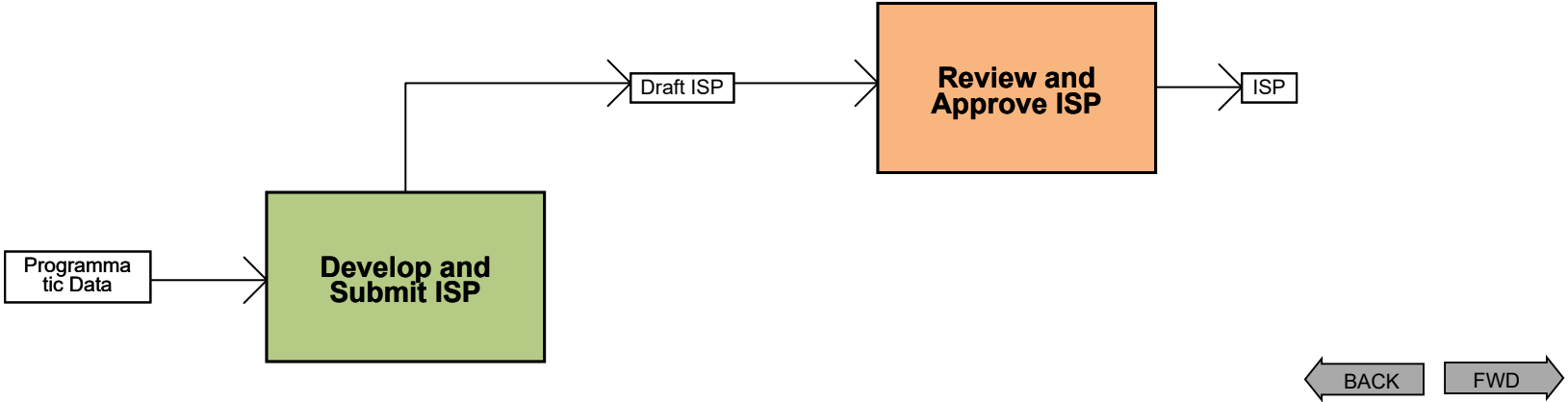

Go Up 1 Level

Acquisition Process Model

1.5.2.1.5.6 Prepare APB

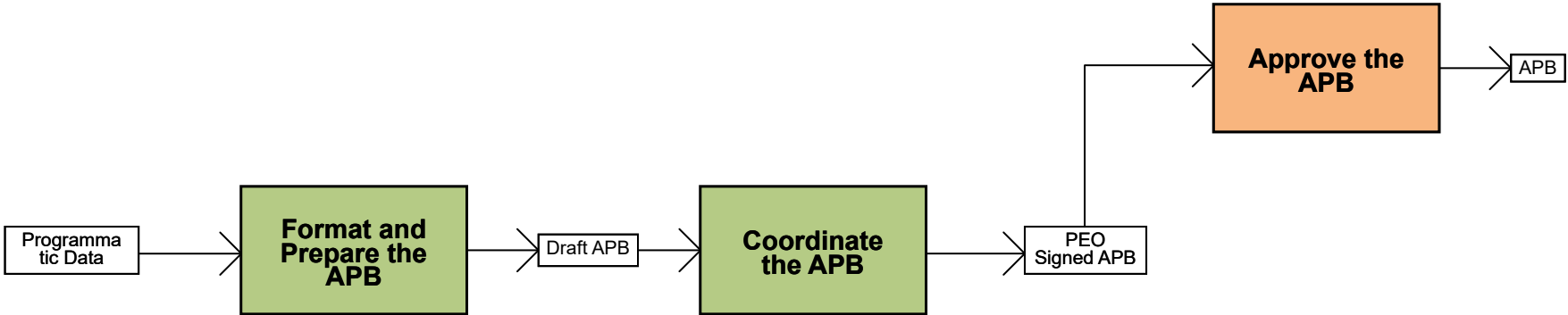

Note: OSD (AT&L) issued APM preparation and review guidance for use in the above process. Click here to access an active link to this guidance.

BACK

Acquisition Process Model

1.5.2.1.6 Manage Program Metrics

Go Up 1 Level

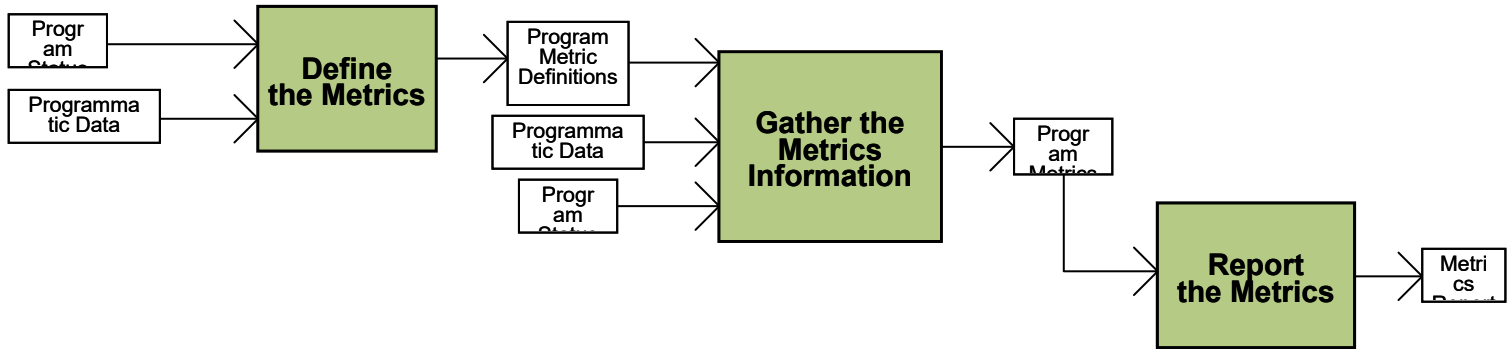

BACK

FWD

Go Up 1 Level

Acquisition Process Model

1.5.2.1.8 Conduct CFO Compliance

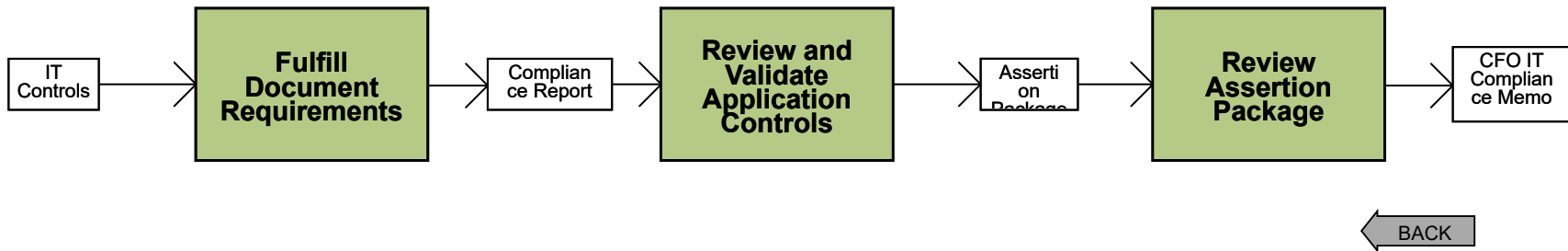

Go Up 1 Level

Acquisition Process Model

1.5.3 Conduct Risk Management

AFLCMC Standard Processes

PEO View

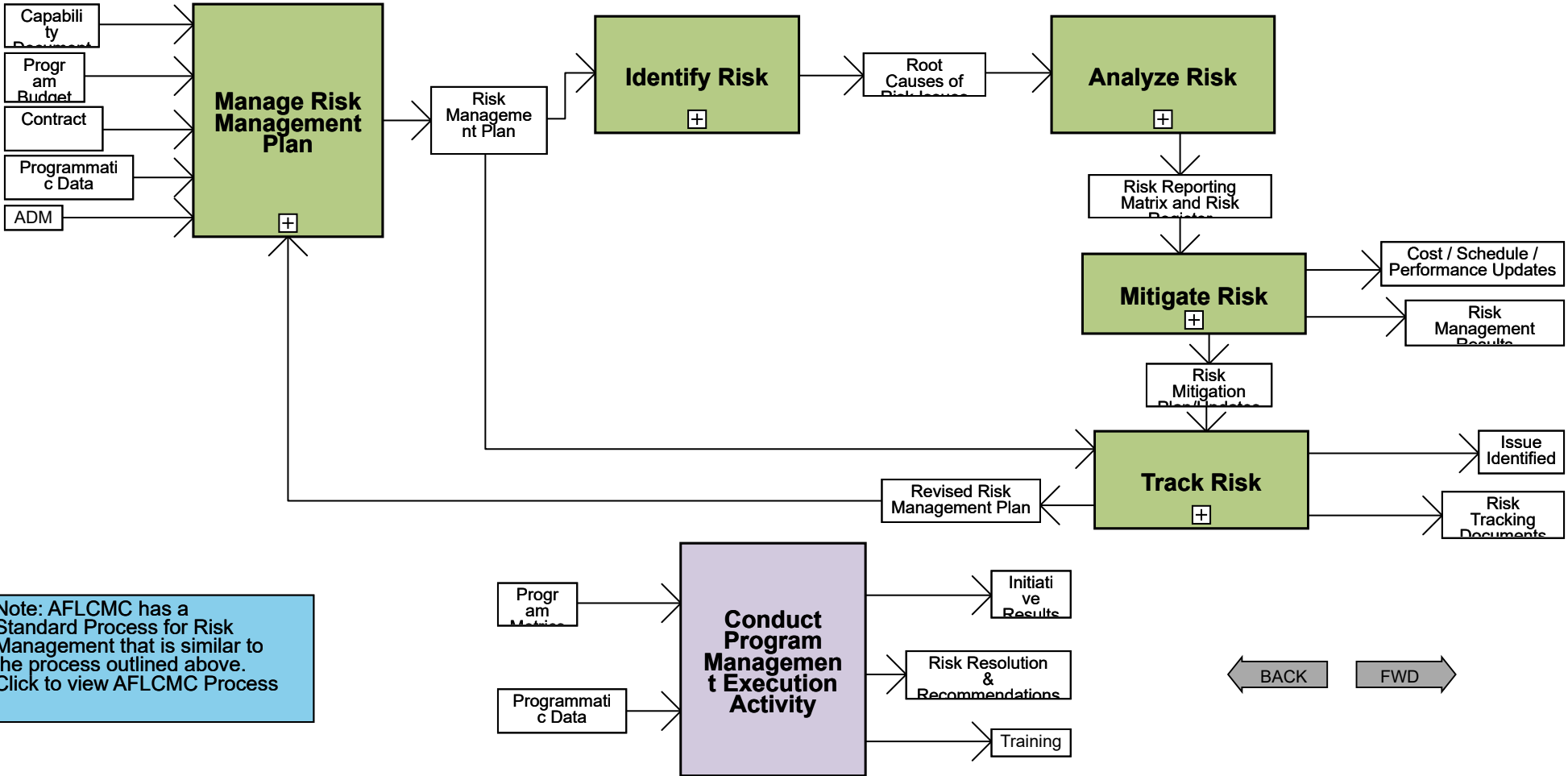

Note: AFLCMC has a Standard Process for Risk Management that is similar to the process outlined above. Click to view AFLCMC Process

Go Up 1 Level

Acquisition Process Model

1.5.3.1 Manage Risk Management Plan

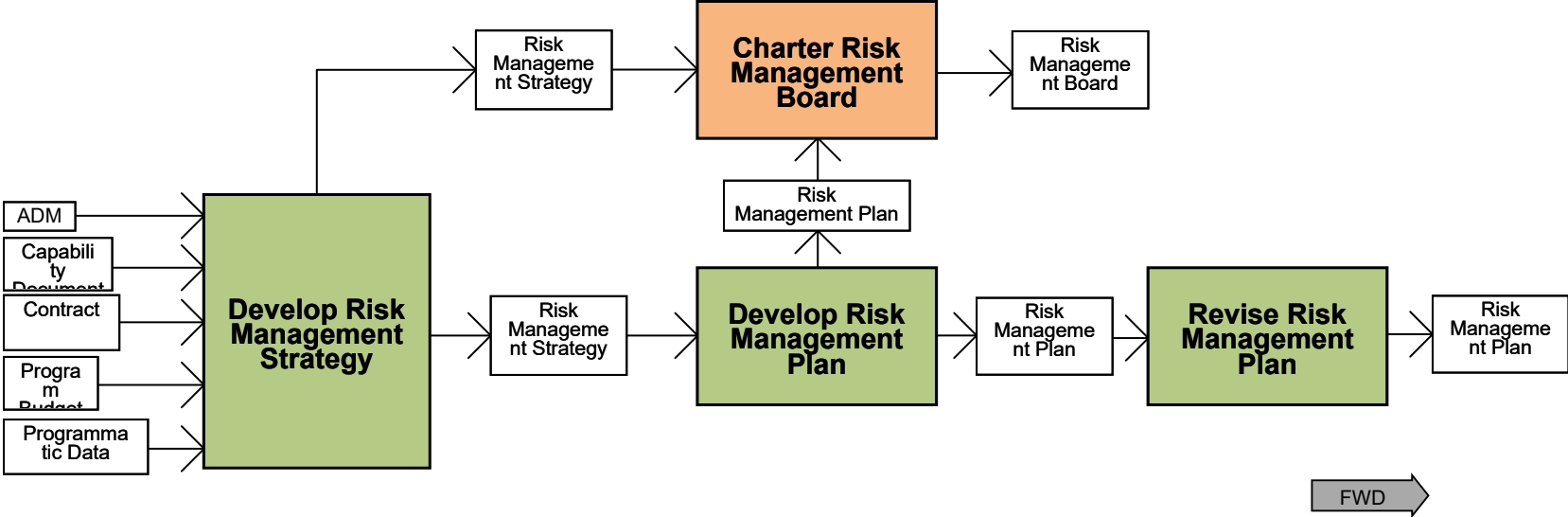

Go Up 1 Level

Acquisition Process Model

1.5.3.2 Track Risk

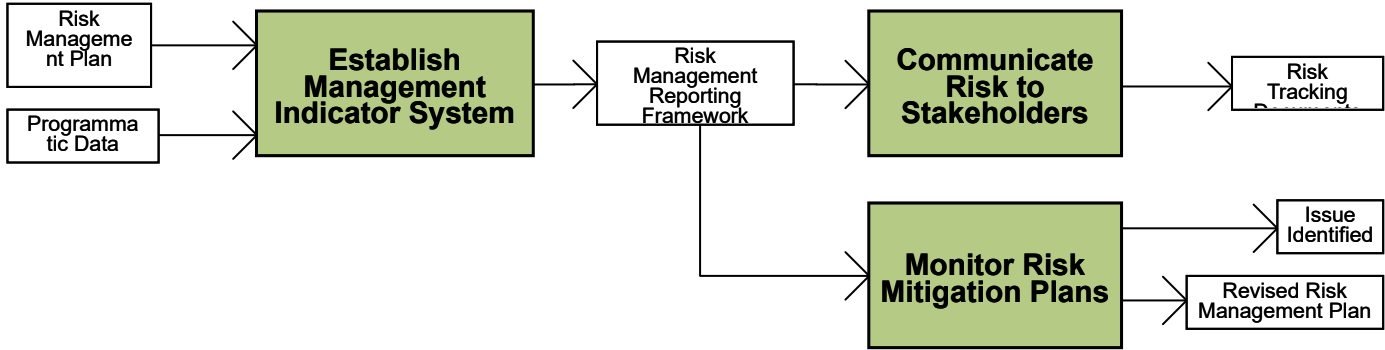

← BACK

FWD →

Go Up 1 Level

Acquisition Process Model

1.5.3.3 Identify Risk

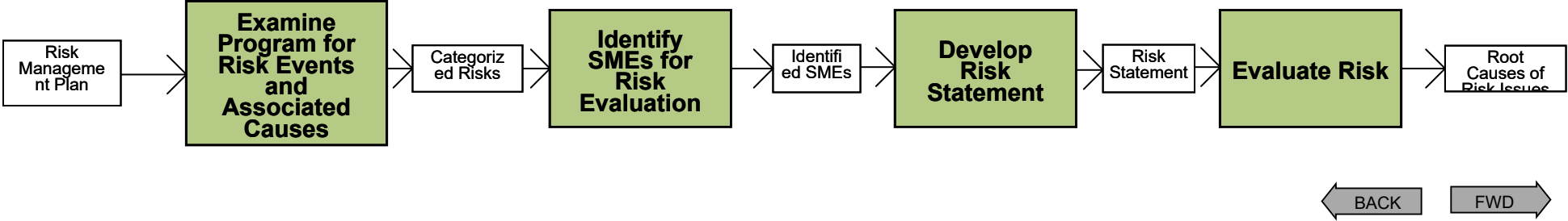

Go Up 1 Level

Acquisition Process Model

1.5.3.4 Analyze Risk

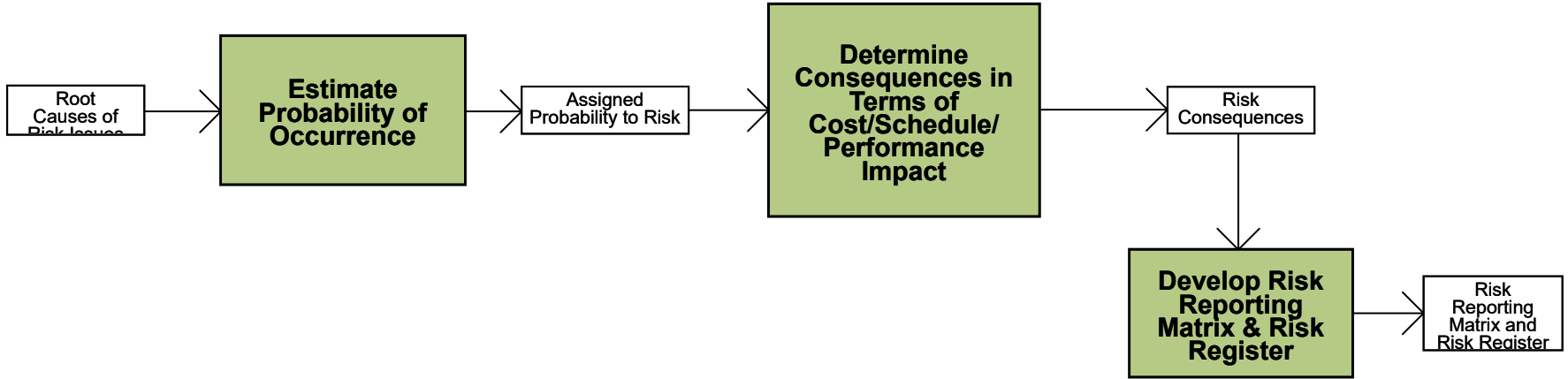

← BACK

FWD →

Go Up 1 Level

Acquisition Process Model

1.5.3.5 Plan Risk Mitigation

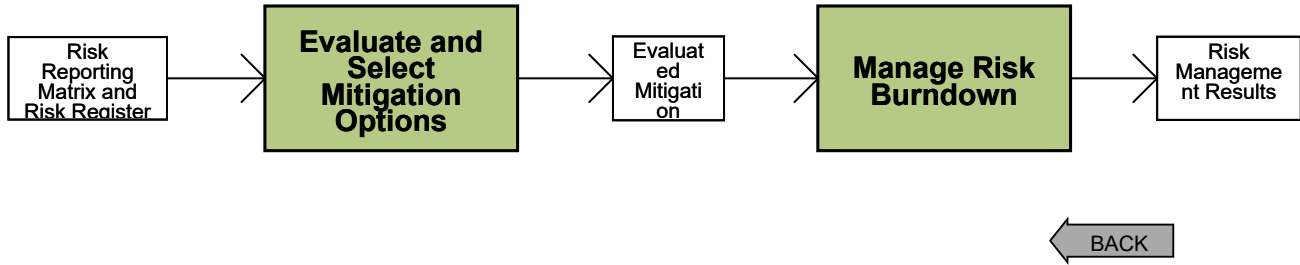

Go Up 1 Level

Acquisition Process Model

1.5.4 Conduct Continuous Process Improvement (CPI)

PEO View

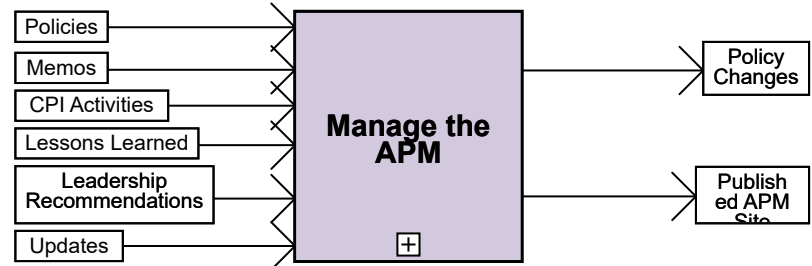
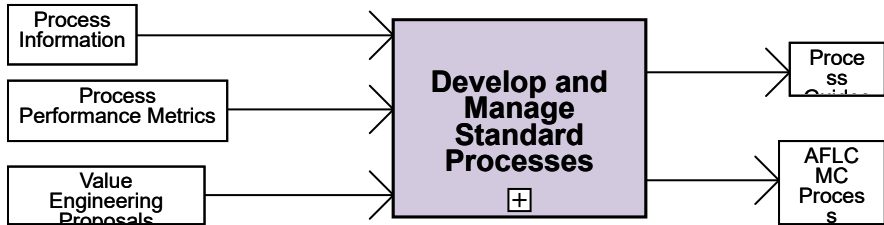
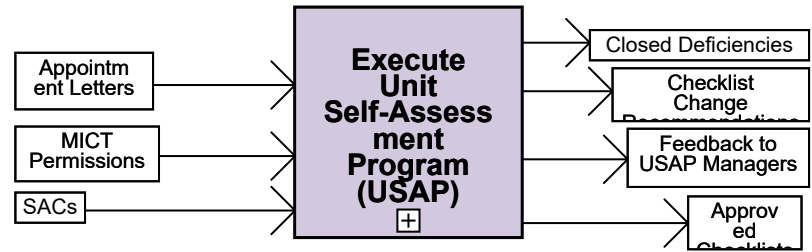
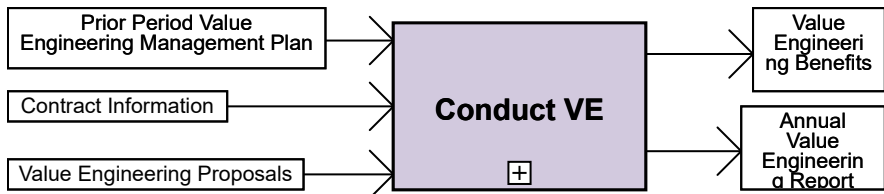
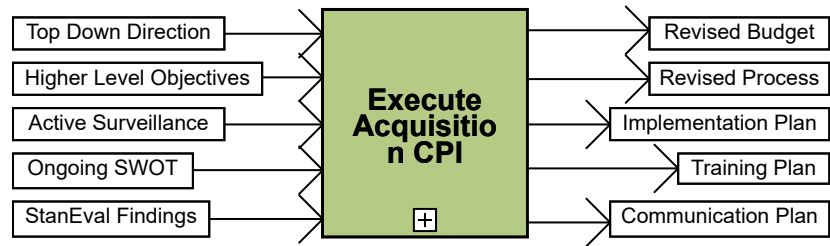
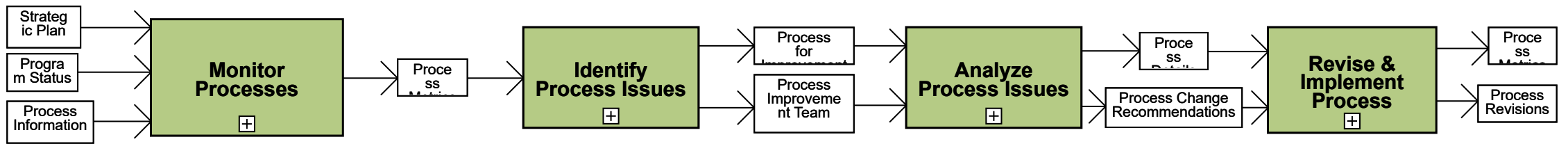
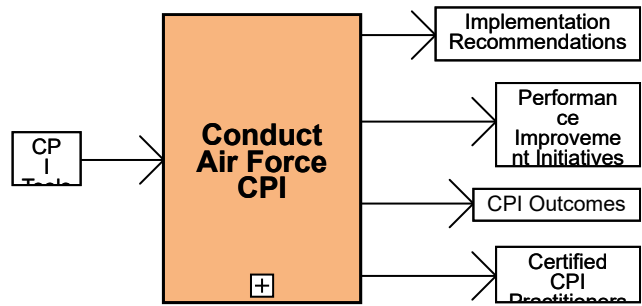

← BACK

Go Up 1 Level

Acquisition Process Model

1.5.4.1 Monitor Processes

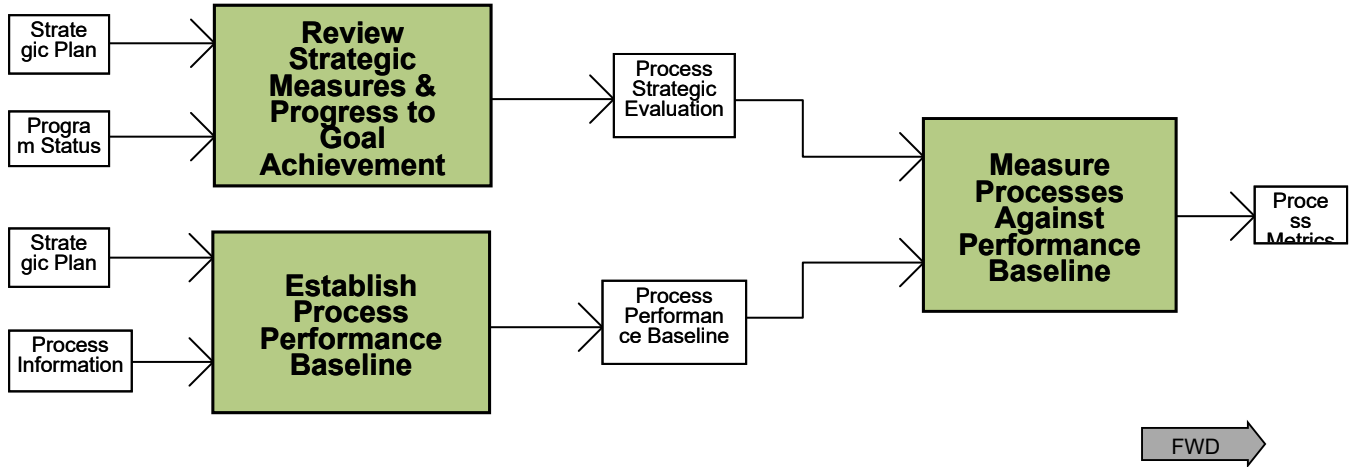

Acquisition Process Model

1.5.4.10 Execute Acquisition CPI

Go Up 1 Level

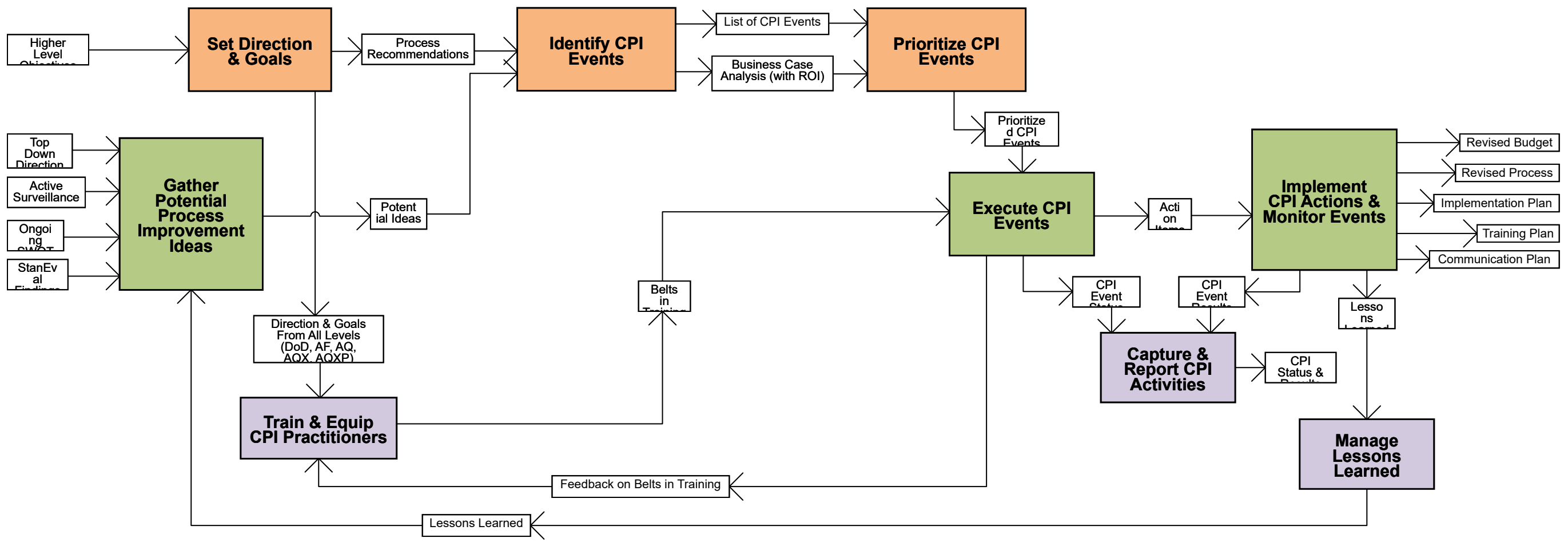

BACK

Go Up 1 Level

Acquisition Process Model

1.5.4.2 Identify Process Issues

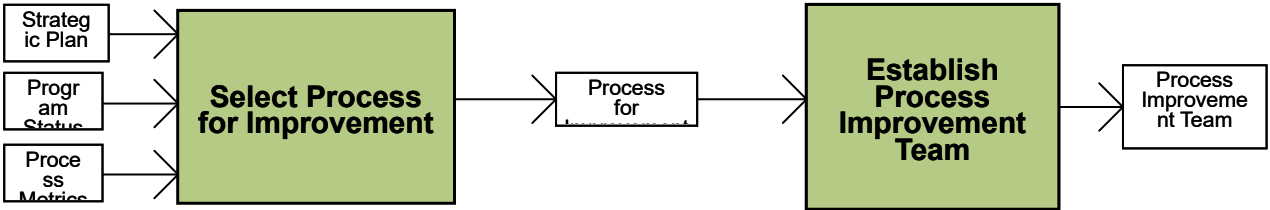

← BACK

FWD →

Go Up 1 Level

Acquisition Process Model

1.5.4.3 Analyze Process Issues

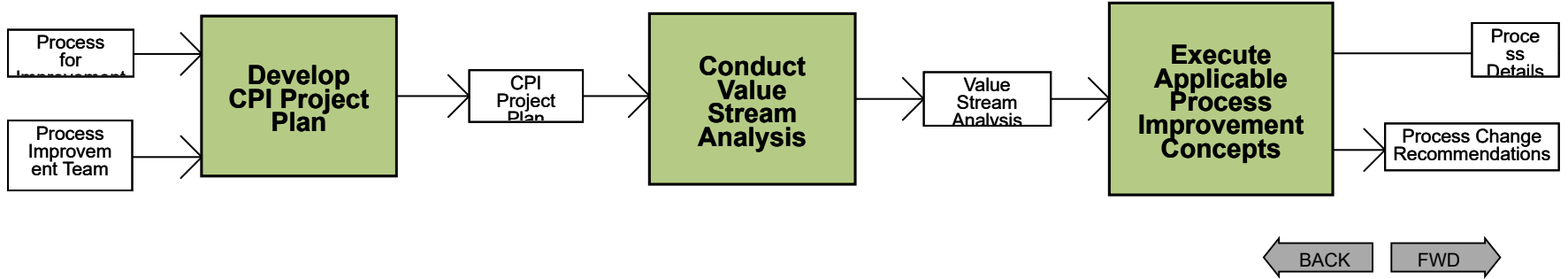

Go Up 1 Level

Acquisition Process Model

1.5.4.4 Revise Process

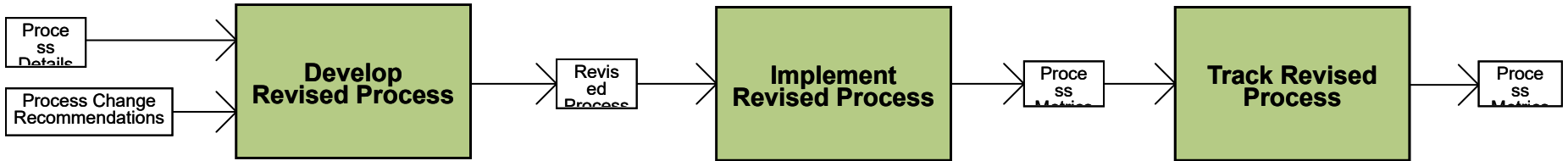

← BACK

FWD →

Acquisition Process Model

1.5.4.5 Conduct VE

Go Up 1 Level

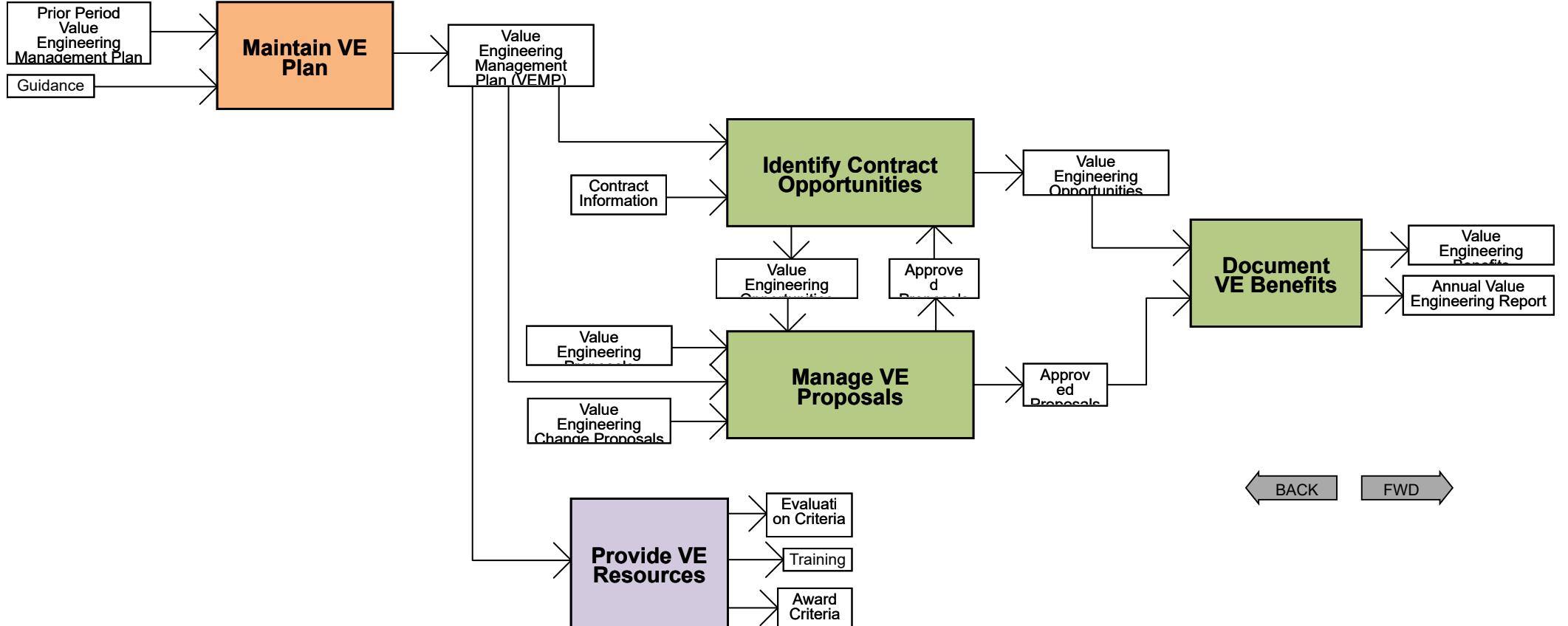

Go Up 1 Level

Acquisition Process Model

1.5.4.6 Execute Unit Self-Assessment Program

AFLCMC Standard Processes

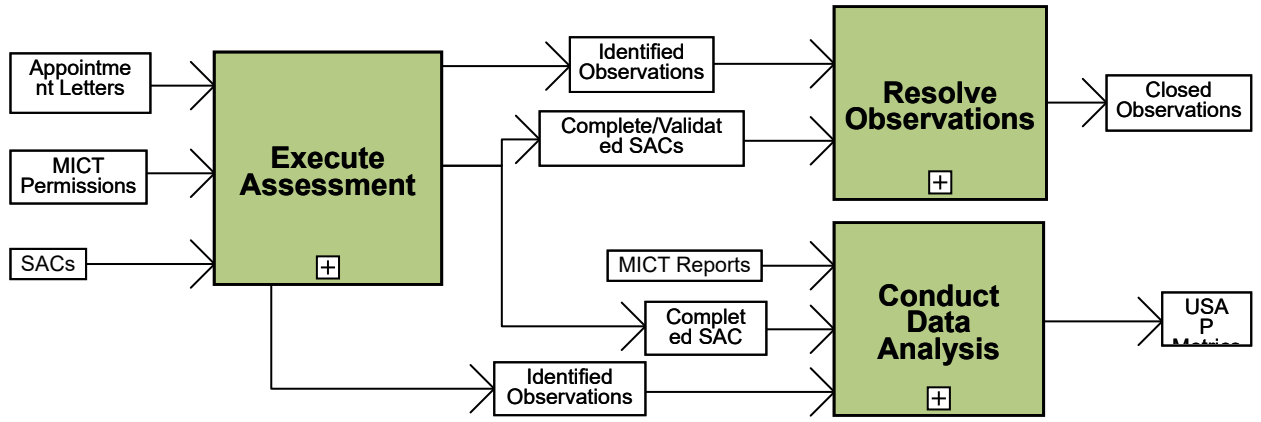

Note: This is an AFLCMC Standard Process.

← BACK FWD →

Go Up 1 Level

Acquisition Process Model

1.5.4.6.1 Execute Assessment

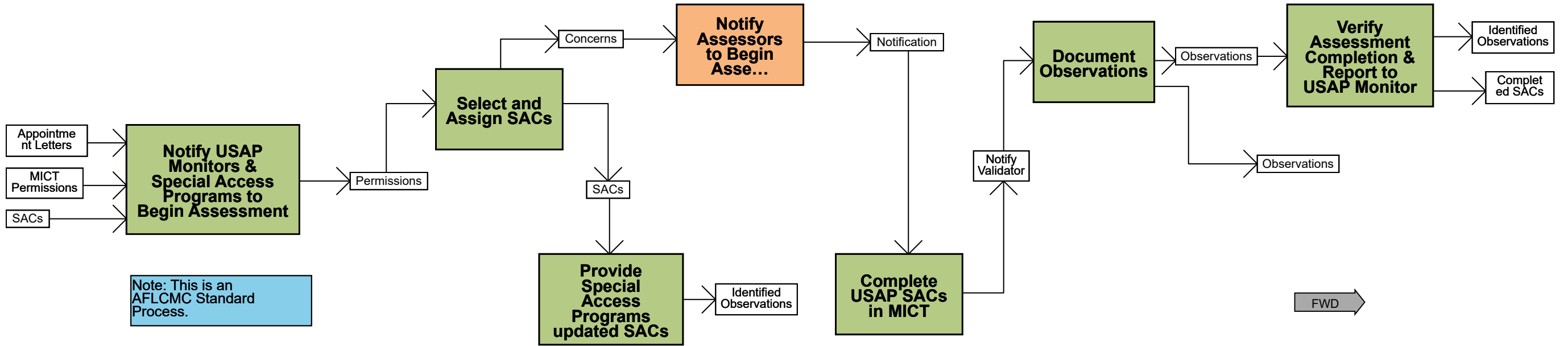

Go Up 1 Level

Acquisition Process Model

1.5.4.6.2 Resolve Observations

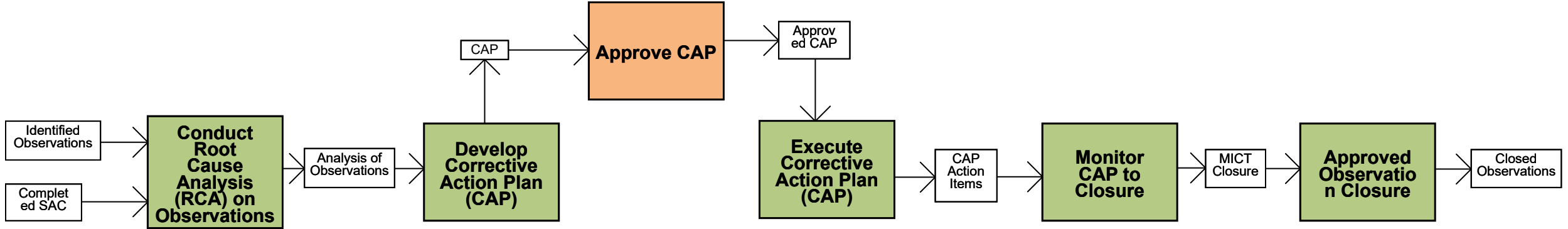

Note: This is an AFLCMC Standard Process.

← BACK FWD →

Go Up 1 Level

Acquisition Process Model

1.5.4.6.3 Conduct Data Analysis

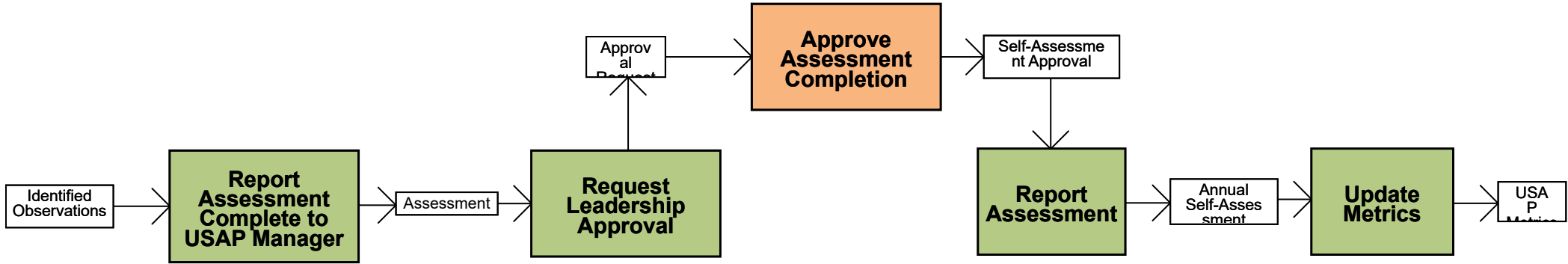

Note: This is an AFLCMC Standard Process.

← BACK

Go Up 1 Level

Acquisition Process Model

1.5.4.7 Develop and Manage Standard Processes

AFLCMC Standard Processes

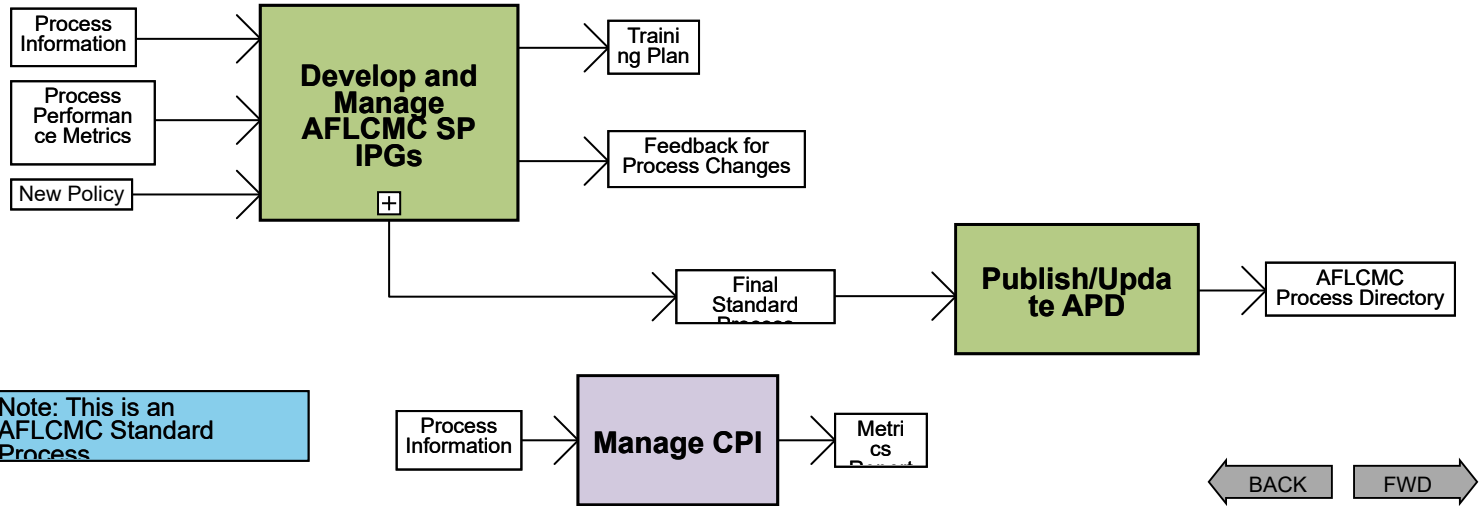

Go Up 1 Level

Acquisition Process Model

1.5.4.7.1 Develop and Manage AFLCMC SP IPGs

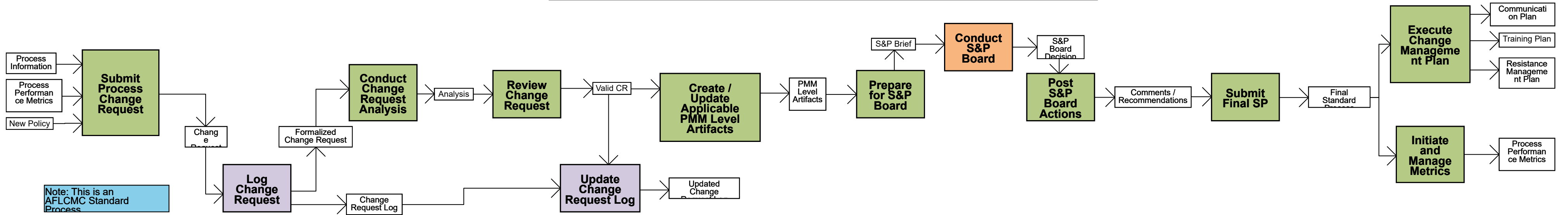

Go Up 1 Level

Acquisition Process Model

1.5.4.8 Conduct Air Force CPI

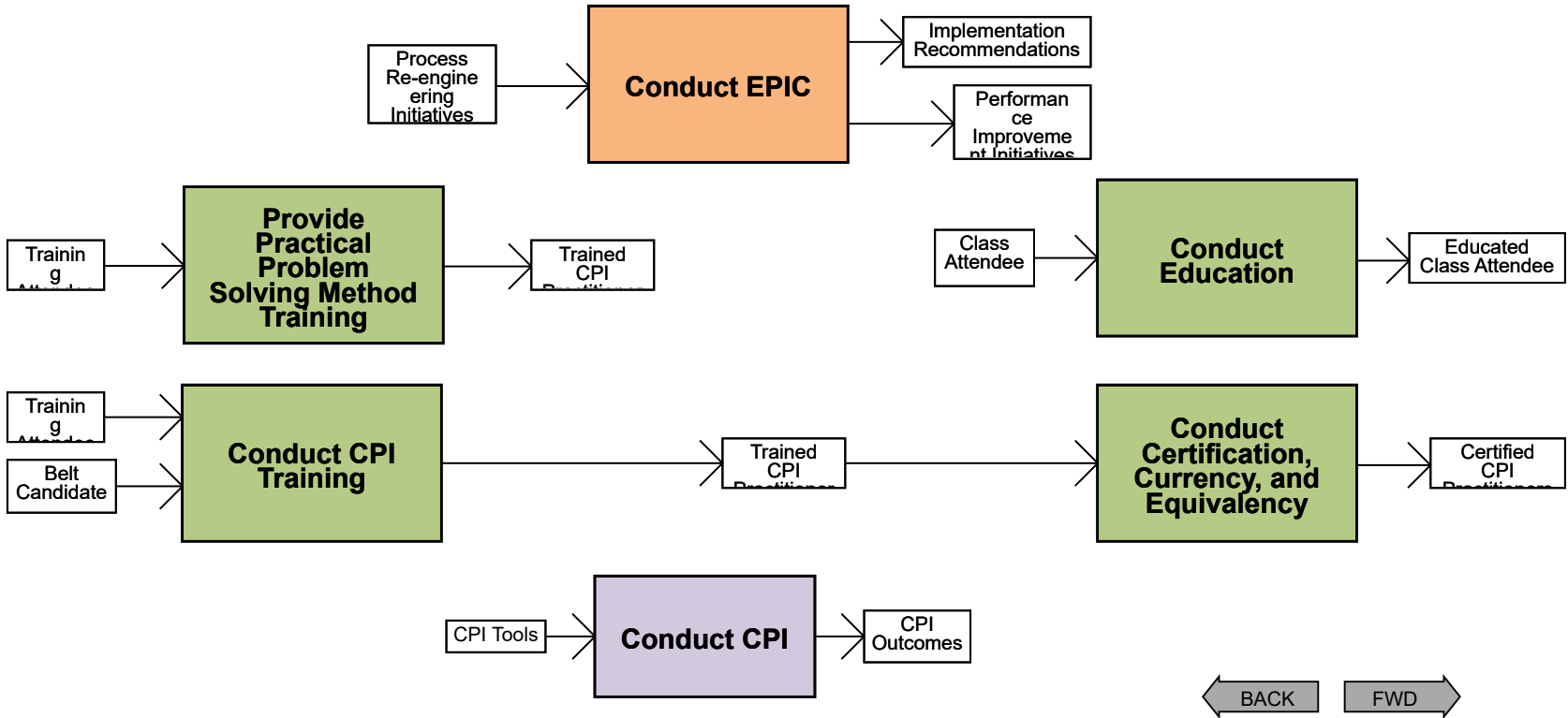

Go Up 1 Level

Acquisition Process Model

1.5.4.9 Manage the APM

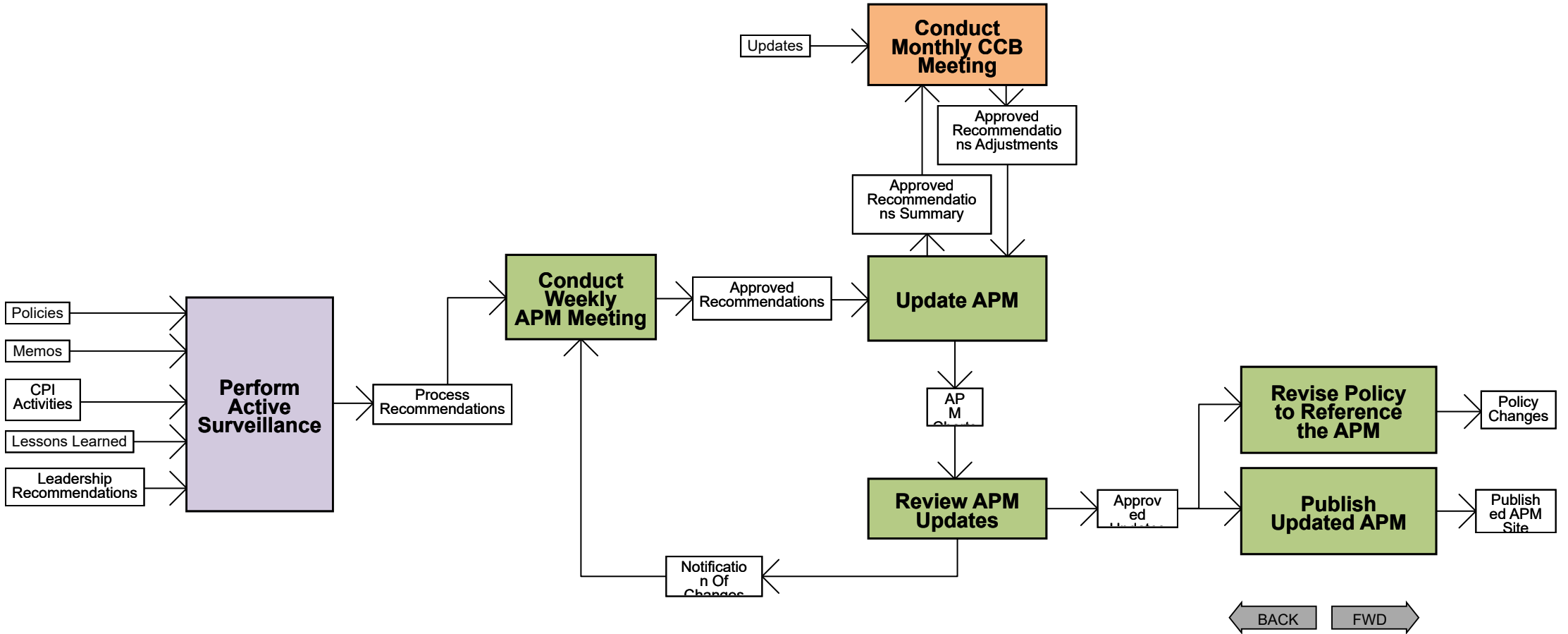

Go Up 1 Level

Acquisition Process Model

3.2 Defense Business System (DBS) Life Cycle Management

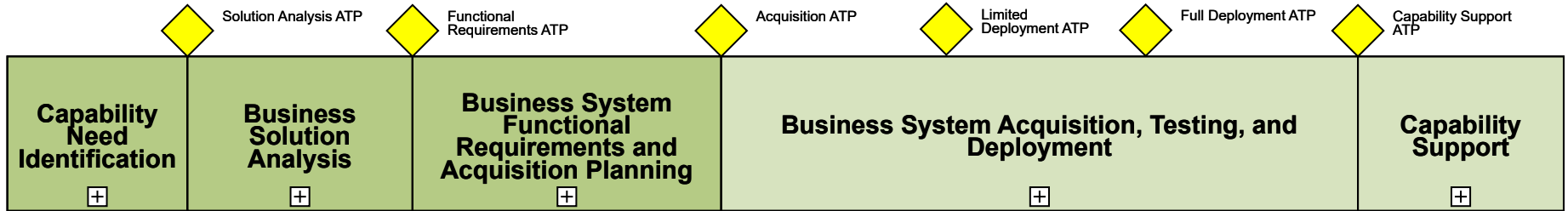

Note: Agile acquisition provides the flexibility to tailor strategies, deliver capability faster to end users and respond to changes in, technology, operations, budgets, and environments. Where appropriate under the process, agile acquisition strategies and techniques will be employed to tailor strategies, processes, documentation, design, development, and test activities. Implementation of business systems should consider Agile Software Development methodologies and techniques as the preferred approach to the technical implementation.

Go Up 1 Level

Acquisition Process Model

3.2.1 Capability Need Identification

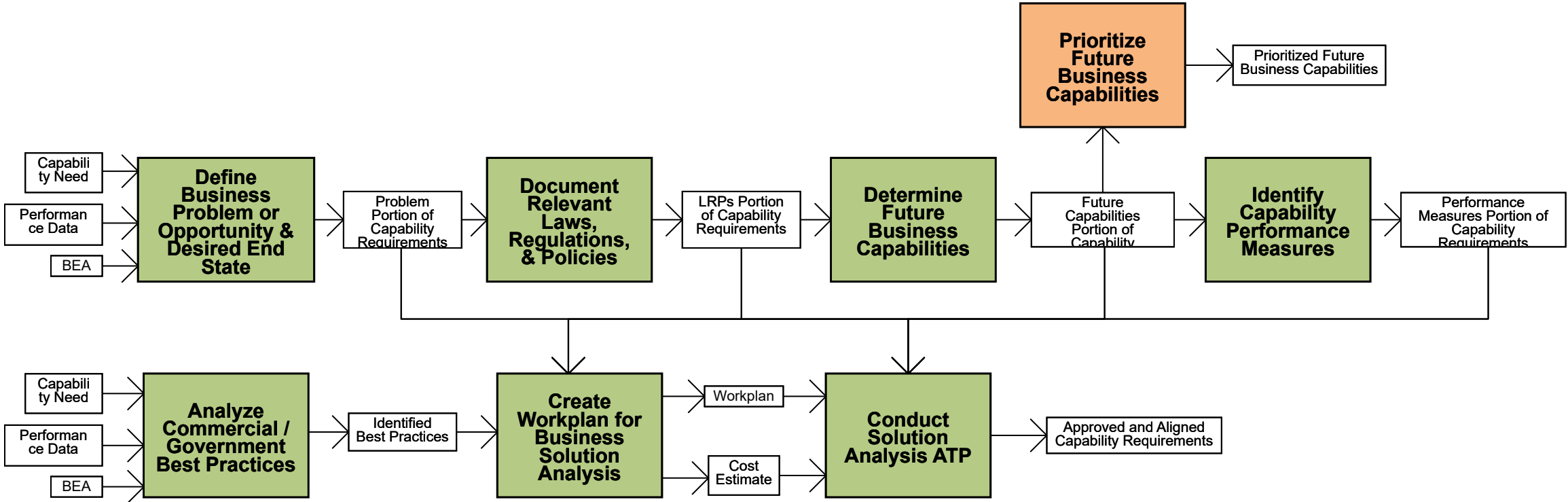

FWD →

Go Up 1 Level

Acquisition Process Model

3.2.2 Business Solution Analysis

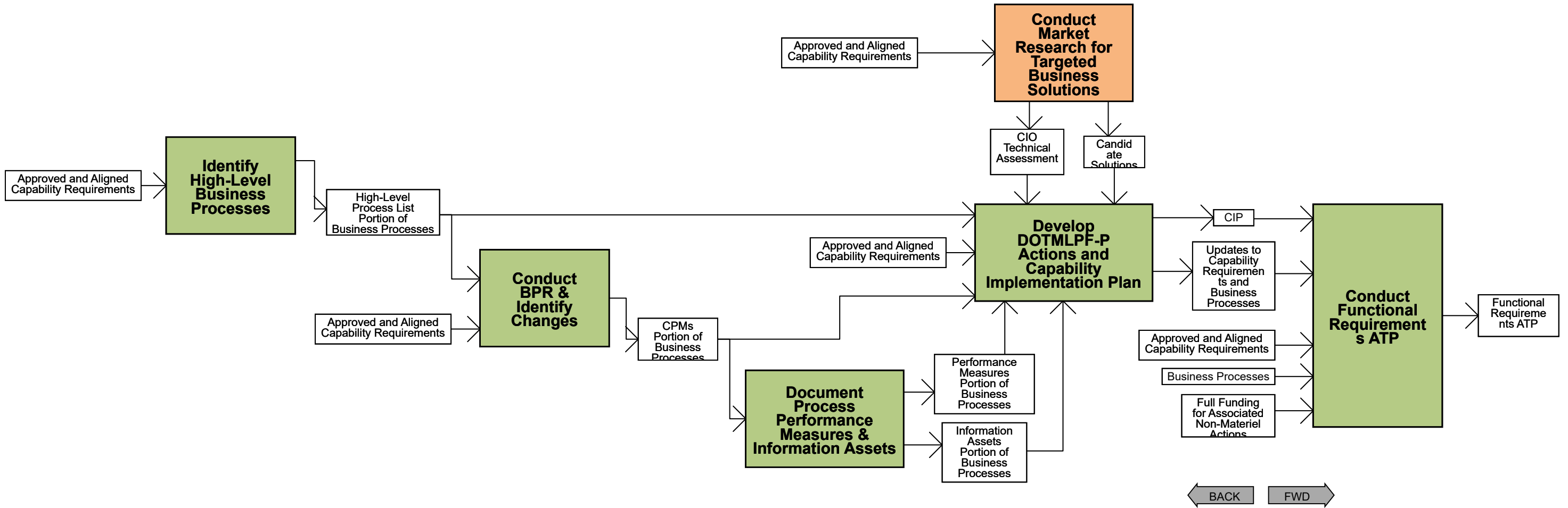

Acquisition Process Model

3.2.3 Business System Functional Requirements and Acquisition Planning

Go Up 1 Level

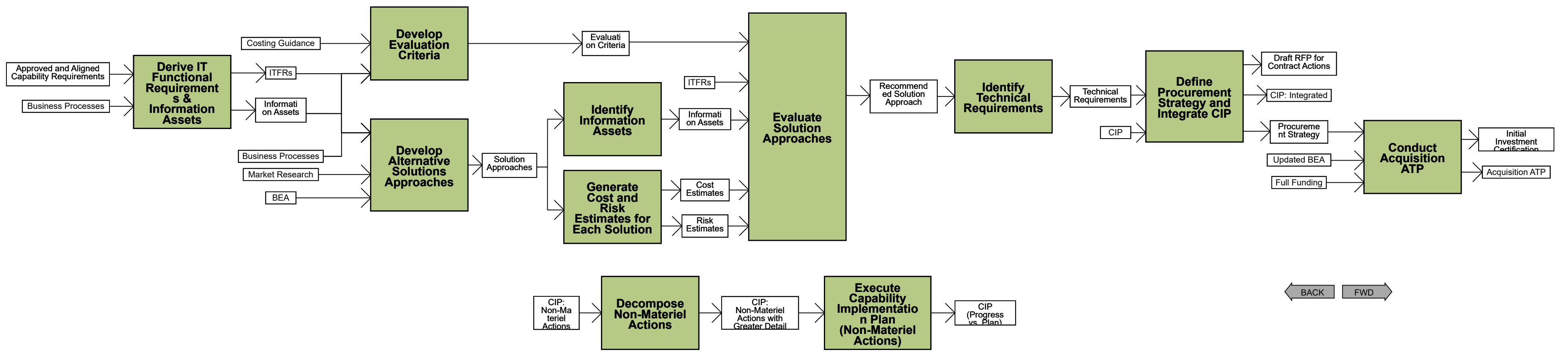

Acquisition Process Model

3.2.4 Business System Acquisition, Testing, and Deployment

Go Up 1 Level

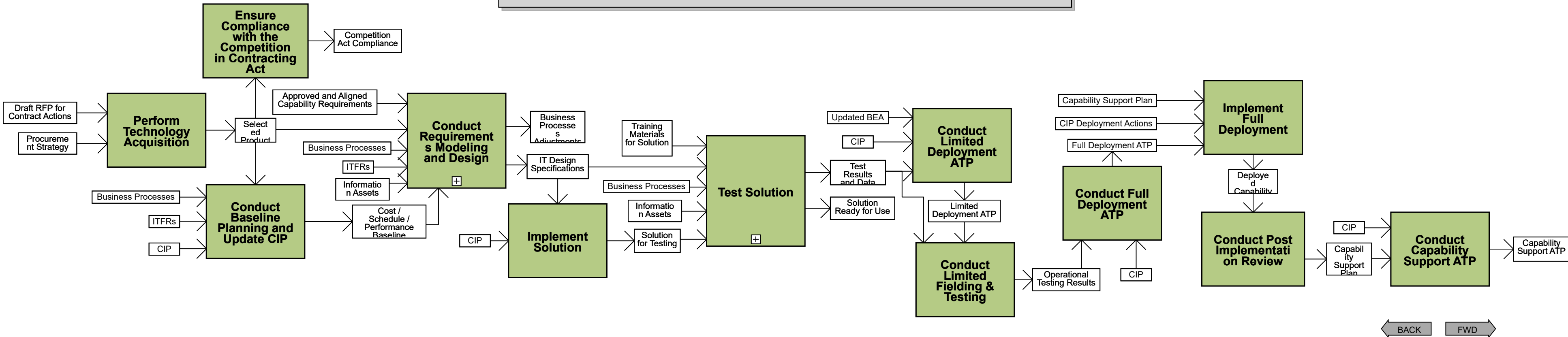

Note: The Program Manager/System Owner, in conjunction with the Functional Lead and Integrated Test Team will consider agile implementation in Phase 4 to support the DoD objective of rapid delivery of capabilities to end user communities at frequent intervals, not only for code development but also for configuration of COTS/GOTS/SaaS products and non-IT acquisitions.

BACK FWD

Acquisition Process Model

3.2.4.3 Conduct Requirements Modeling and Design

Go Up 1 Level

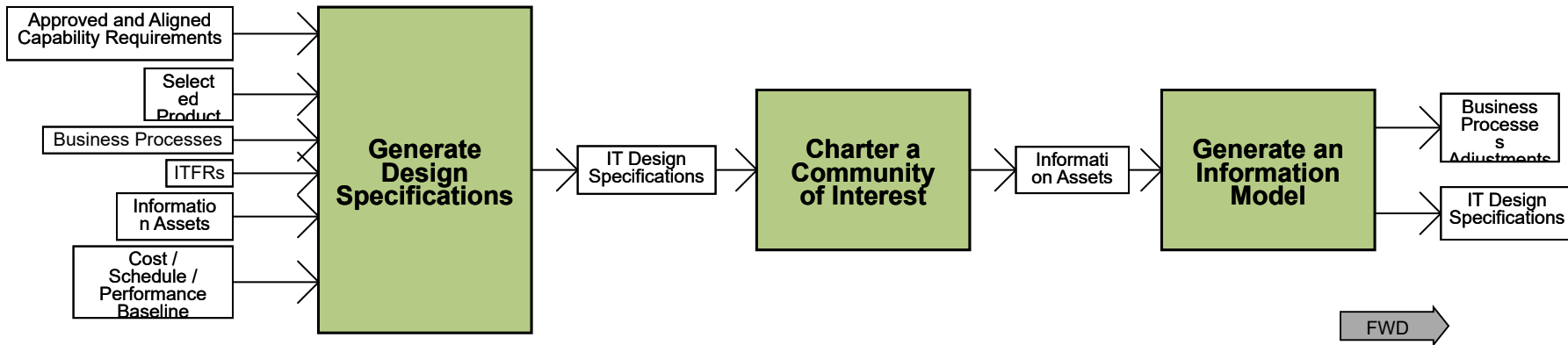

Acquisition Process Model

3.2.4.5 Test Solution

Go Up 1 Level

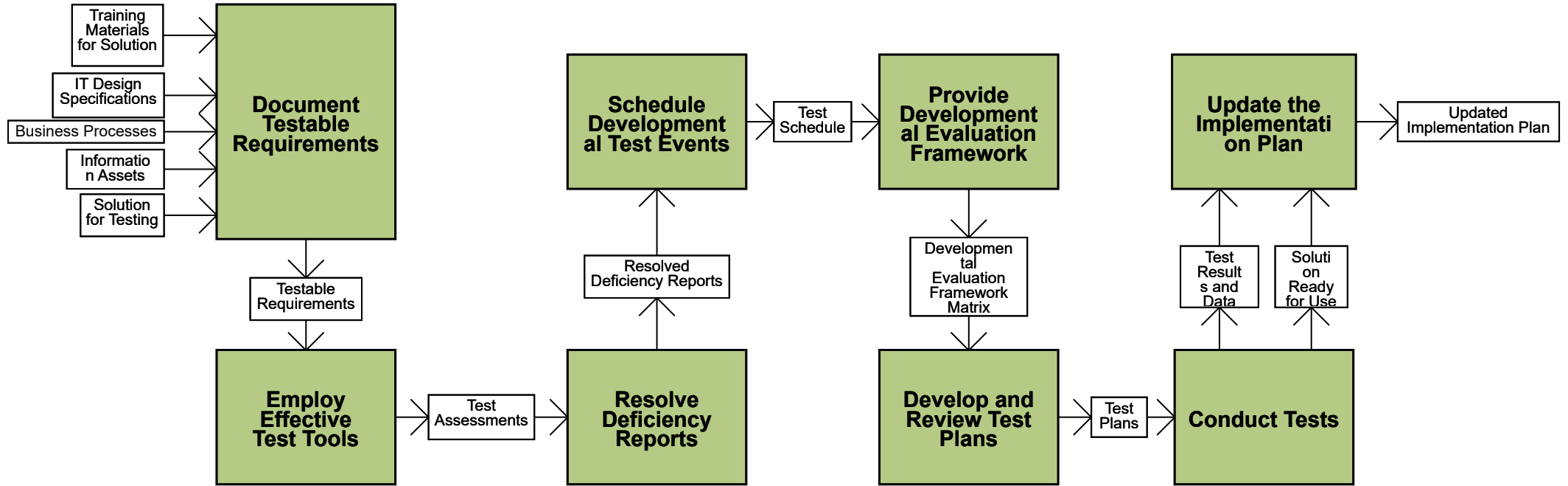

BACK

Go Up 1 Level

Acquisition Process Model

3.2.5 Capability Support

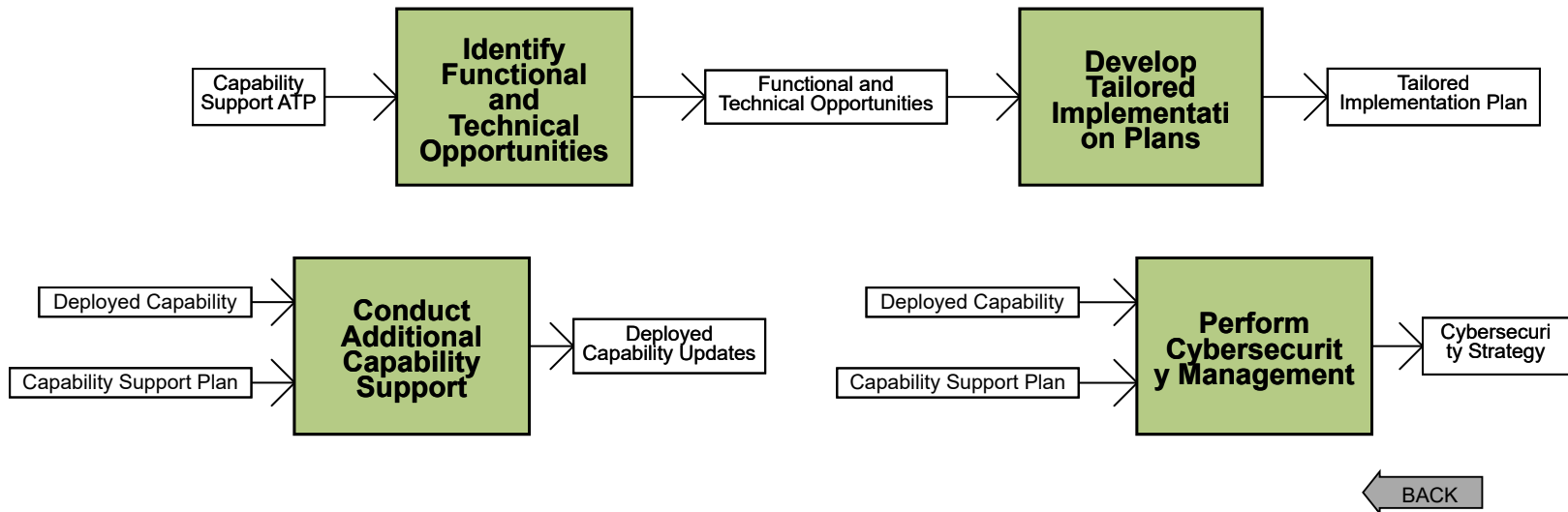

Go Up 1 Level

Acquisition Process Model

AFLCMC Standard Processes

PEO View

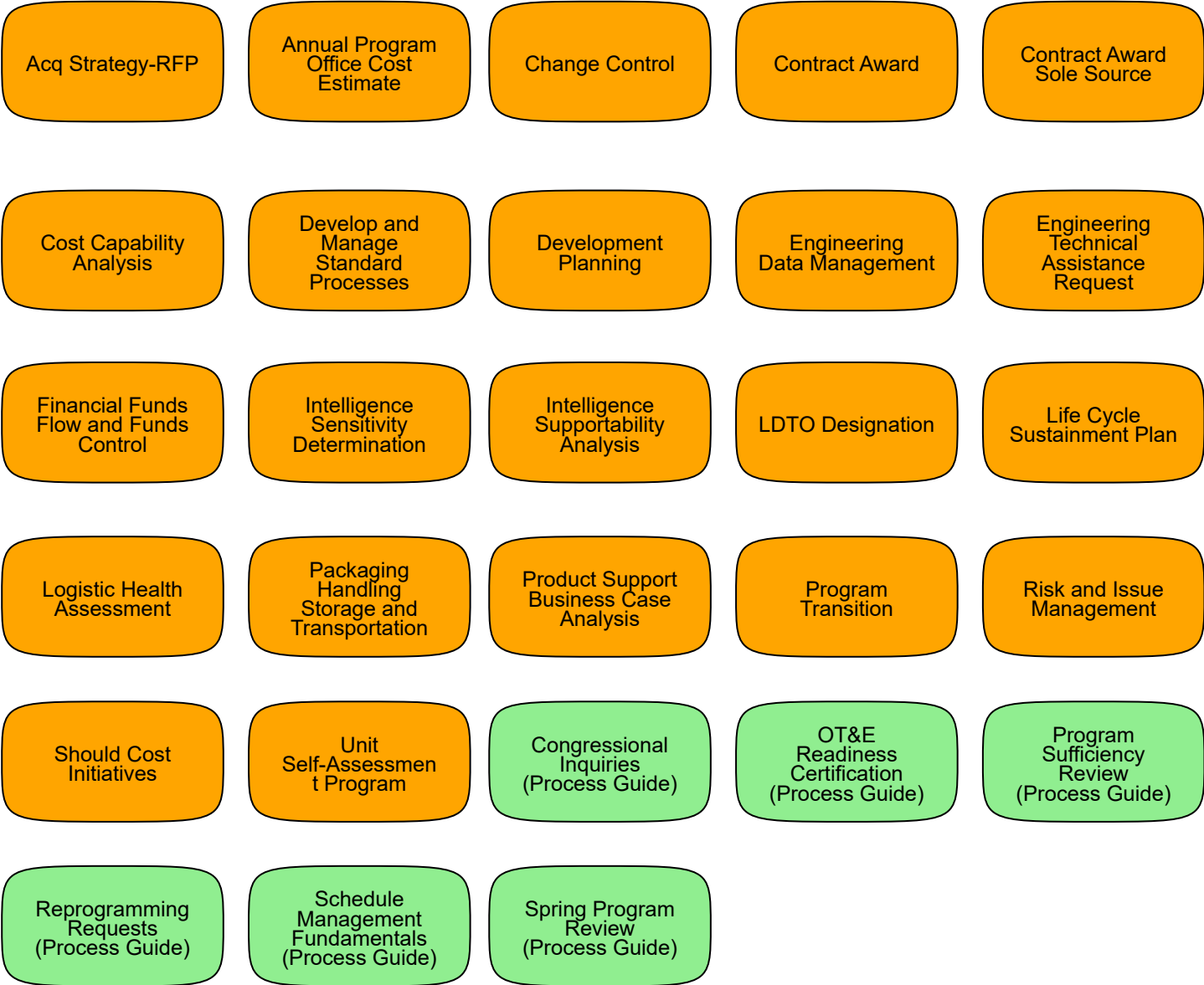

Go Up 1 Level

Acquisition Process Model

Defense Acquisition Management System Models

Model 1 - Hardware Intensive Program



Model 2 - Defense Unique Software Intensive Program



Model 3 - Incrementally Fielded Software Intensive Program



Model 4 - Accelerated Acquisition Program



Model 5 - Hybrid - Hardware Dominant Program



Model 6 - Hybrid - Software Dominant Program





Go Up 1 Level

Acquisition Process Model

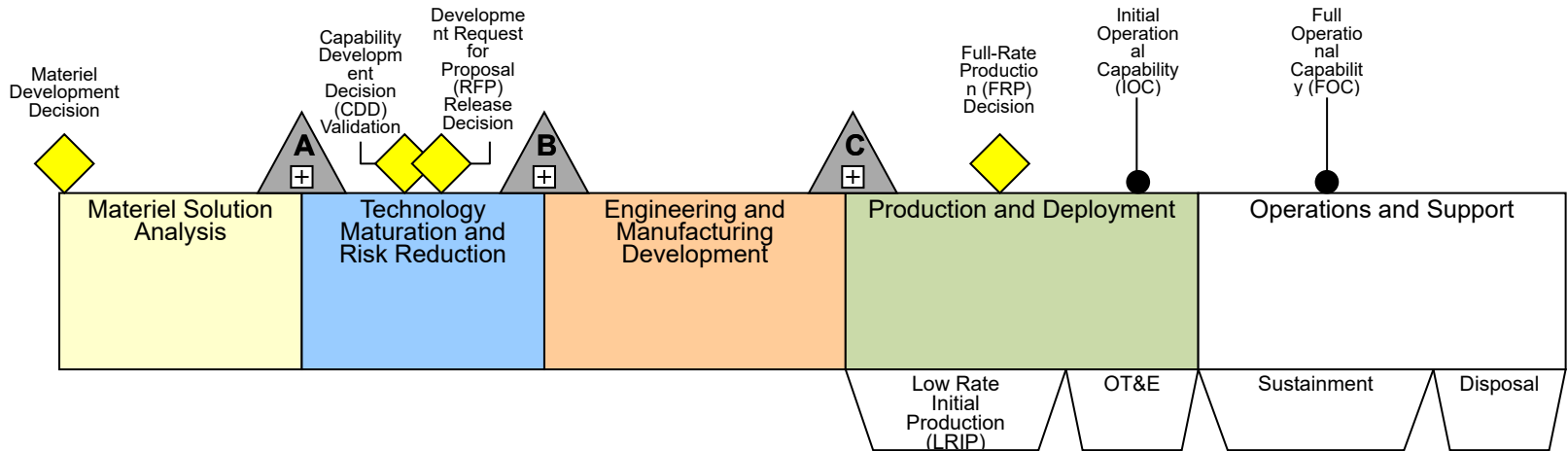
Defense Acquisition System Model 1: Hardware Intensive Program



Legend

-  Milestone Review
-  Decision

Go Up 1 Level

Acquisition Process Model

Defense Acquisition System Model 2: Software Intensive Program

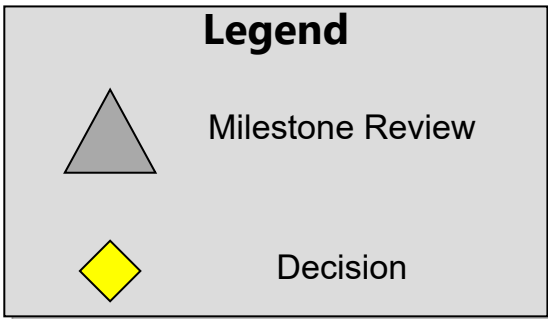
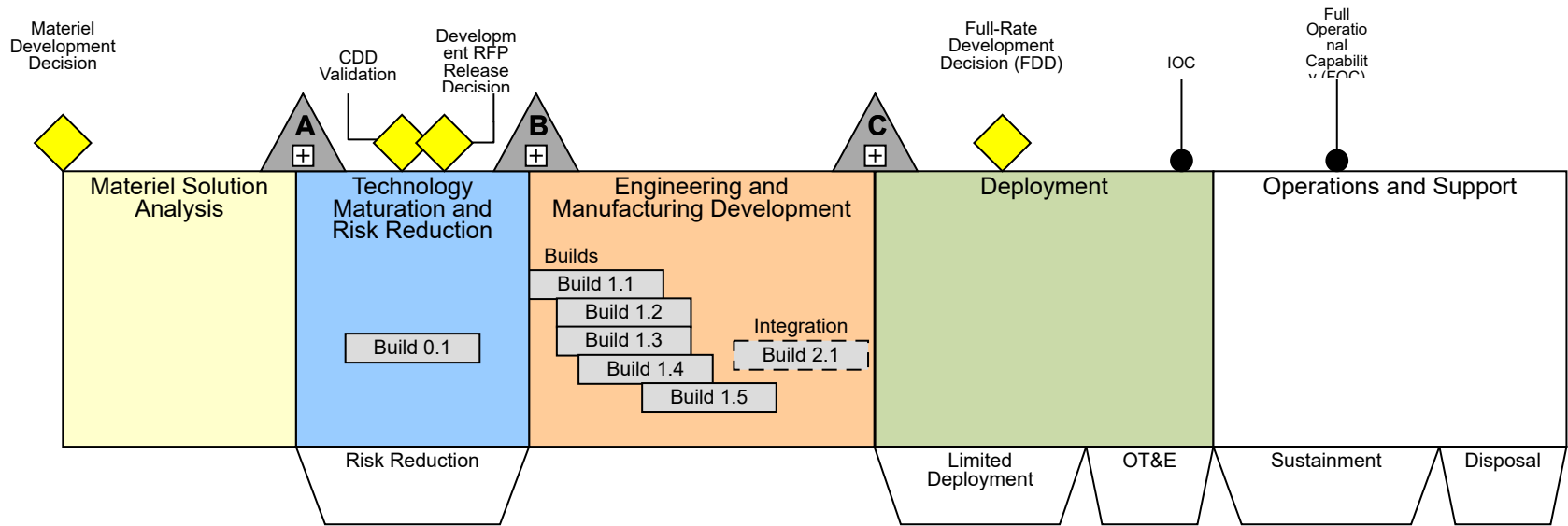

Go Up 1 Level

Acquisition Process Model

Defense Acquisition System Model 3: Incrementally Fielded Software Program

Defense Business System (DBS)

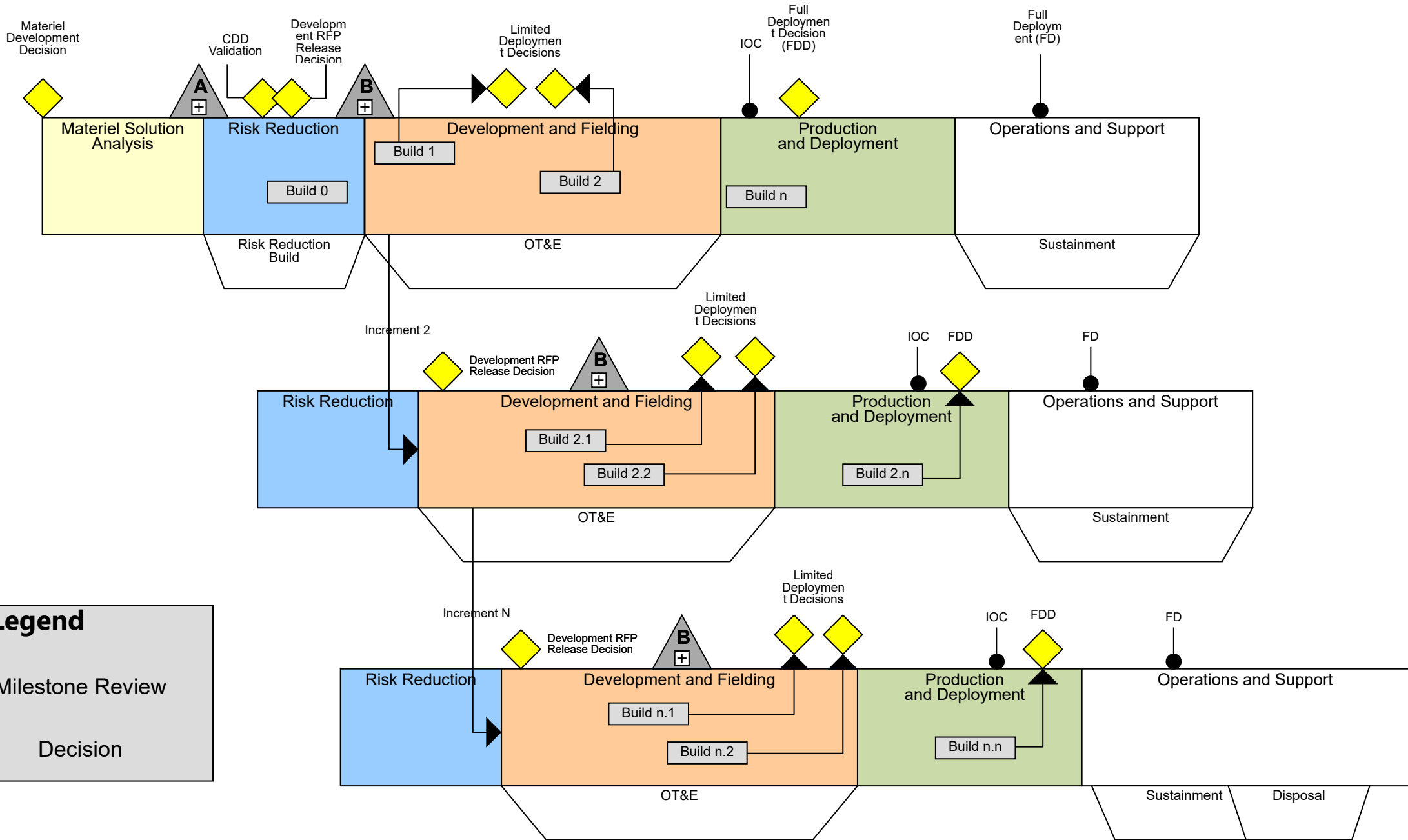

Go Up 1 Level

Acquisition Process Model

Defense Acquisition System Model 4: Accelerated Acquisition Program

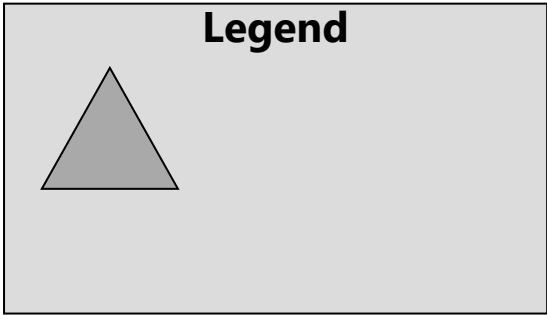
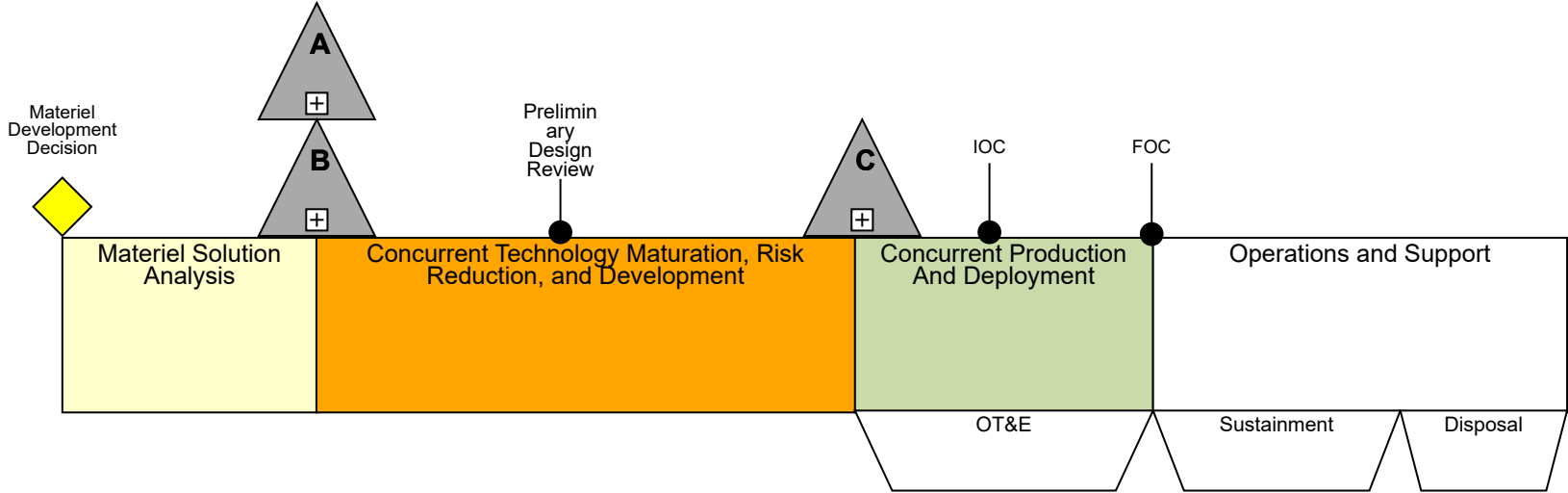



Go Up 1 Level

Acquisition Process Model

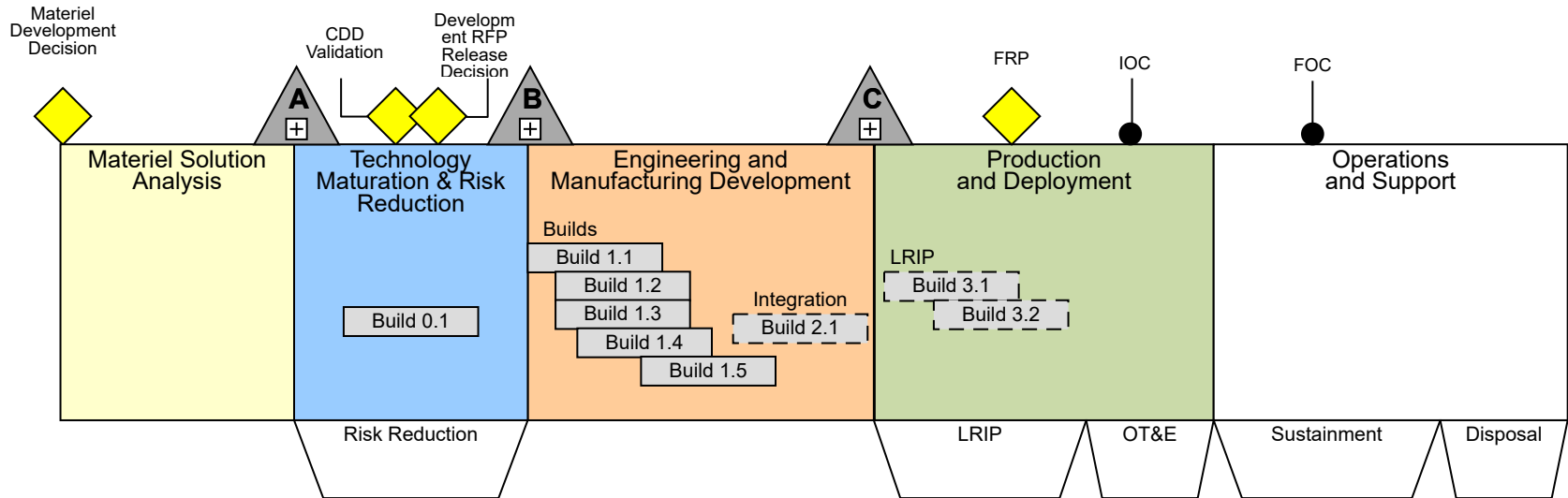
Defense Acquisition System Model 5: Hybrid Acquisition Programs (Hardware Dominant) View



Legend

-  Milestone Review
-  Decision

Go Up 1 Level

Acquisition Process Model

Defense Acquisition System Model 6: Hybrid Acquisition Programs (Software Dominant) View

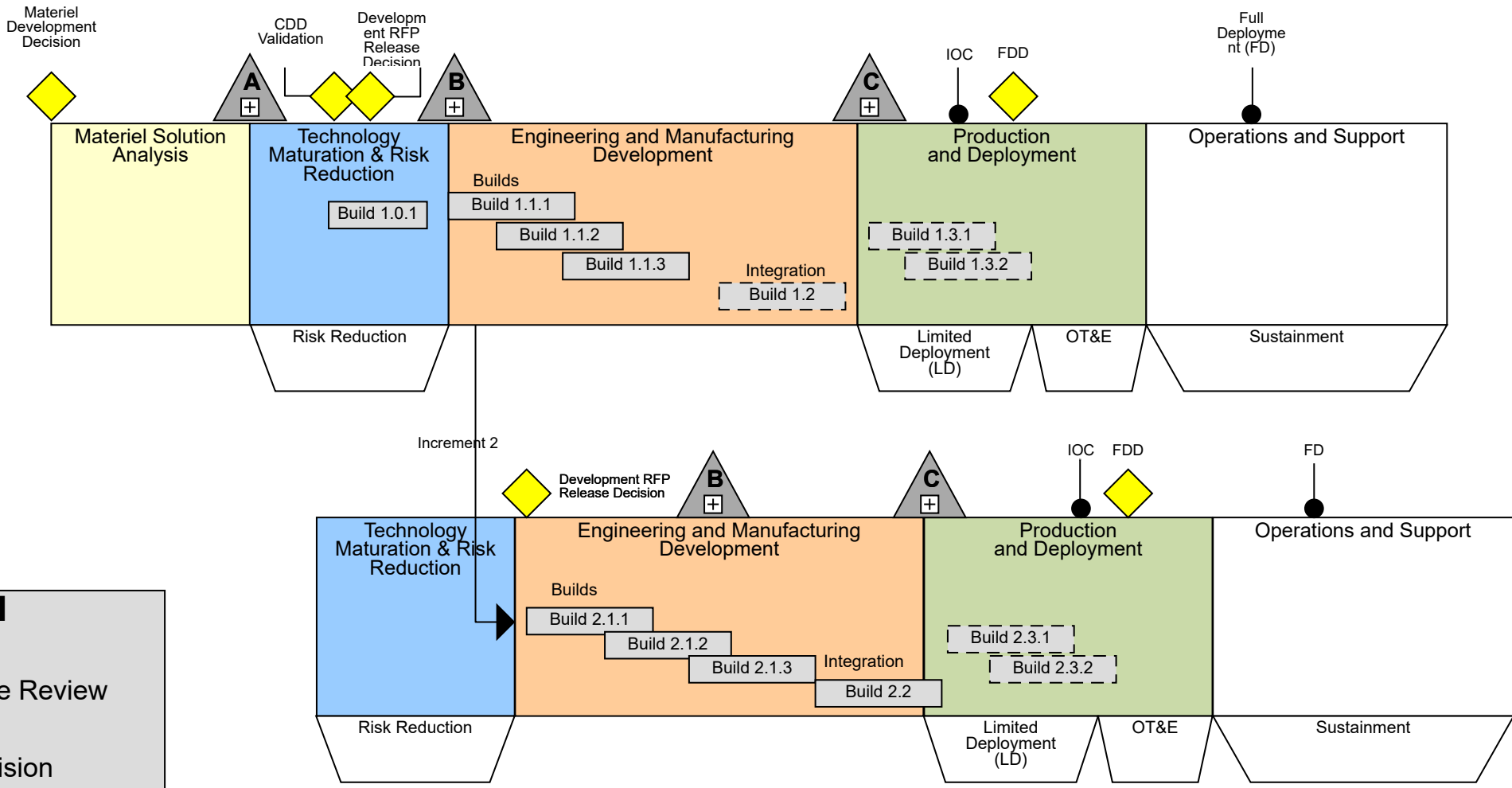

Legend

- Milestone Review (represented by a grey triangle with a plus sign)
- Decision (represented by a yellow diamond)

Go Up 1 Level

Acquisition Process Model

Development RFP Release Decision Point Statutory and Regulatory Information Requirements ACAT III

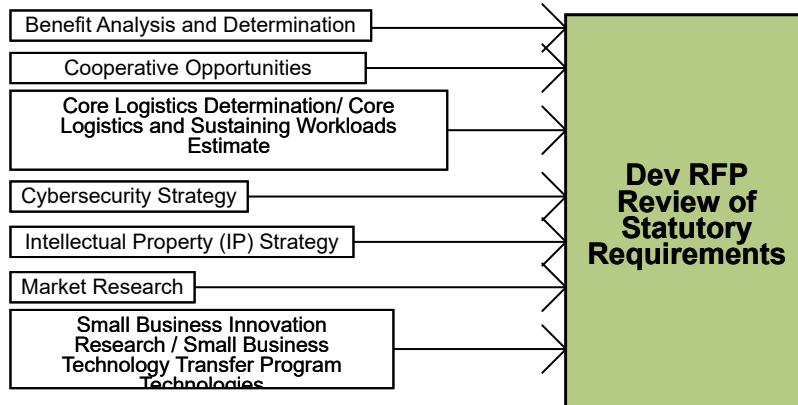

Dev RFP Statutory and Regulatory Information Requirements ACAT I

Dev RFP Statutory and Regulatory Information Requirements ACAT II

Note 1: From DoD 5000.2 Enclosure 1 Statutory & Regulatory Information and Milestone Requirements

Note 2: Click here to access a link to an Air Staff Acquisition Document Coordination Matrix

Note 3: Public Law 114-328 repealed Title 10, Section 2434 effective 23 Dec 2016.

Note 4: Defense Intelligence Threat Library (Threat Modules) is a regulatory requirement with required update every 2 years. DIAD 5000.200 and DIAI 5000.002 are reference documents.

Note 5: Click here for DAU's MDID Tool

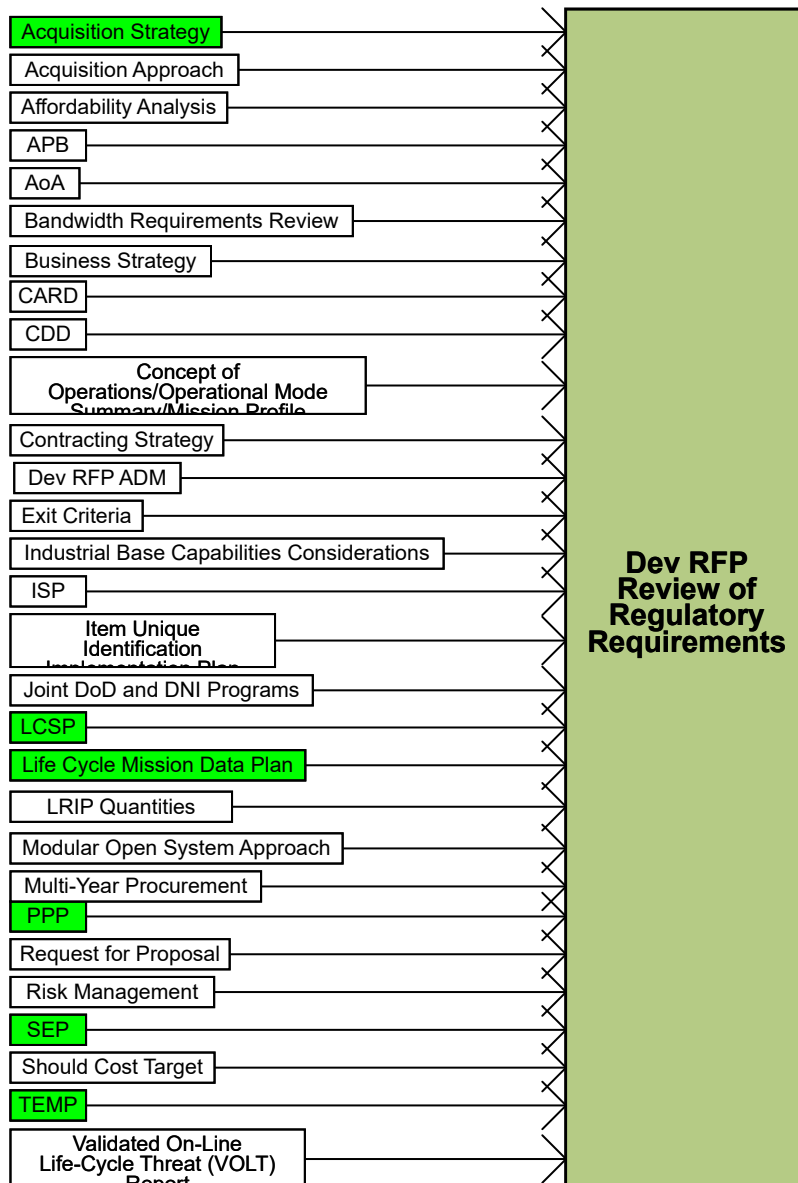

BACK

FWD

Go Up 1 Level

Acquisition Process Model

Development RFP Release Decision Point
Statutory and Regulatory Information
Requirements ACAT I

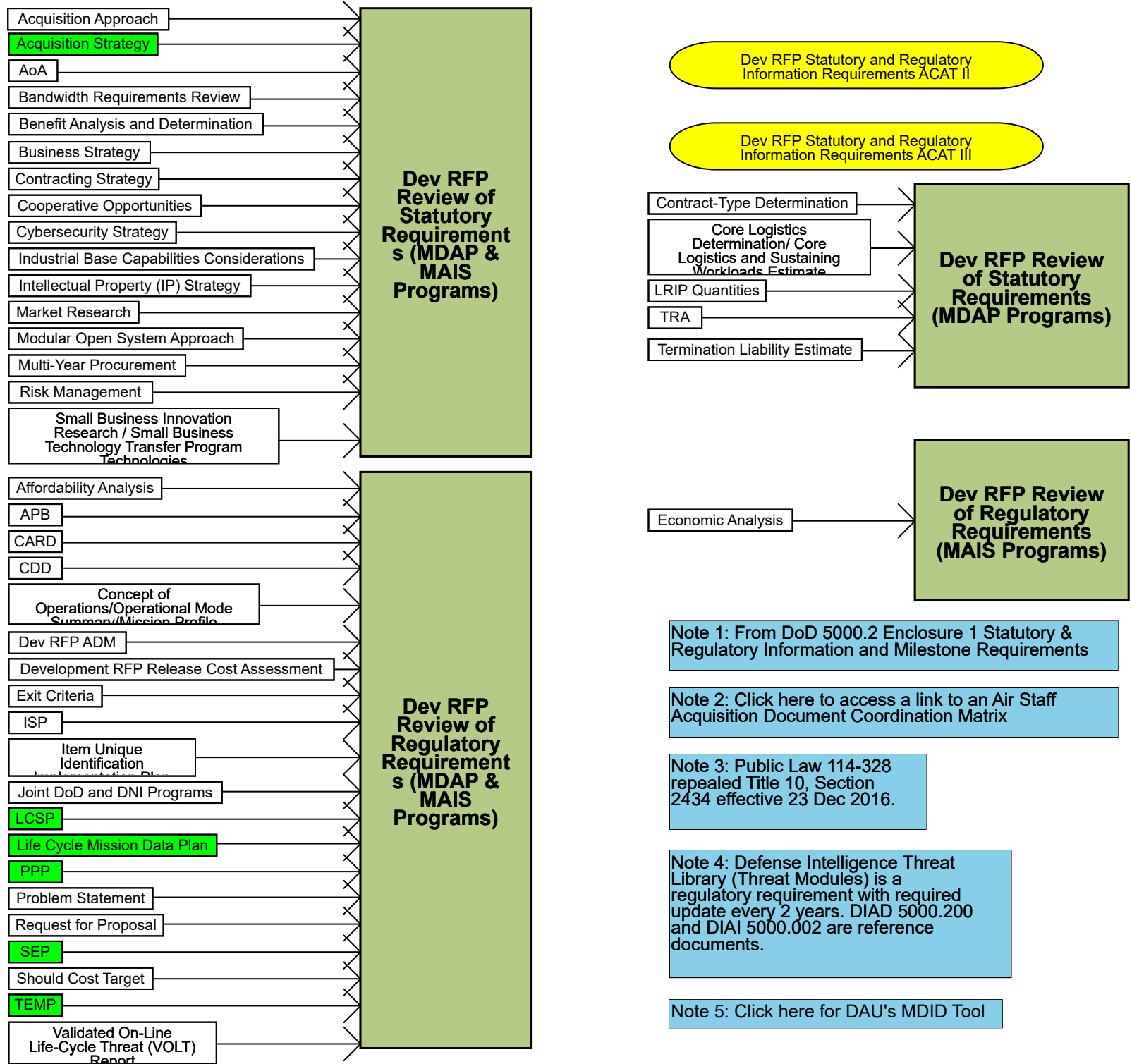

BACK

FWD

Go Up 1 Level

Acquisition Process Model

Development RFP Release Decision Point Statutory and Regulatory Information Requirements ACAT II

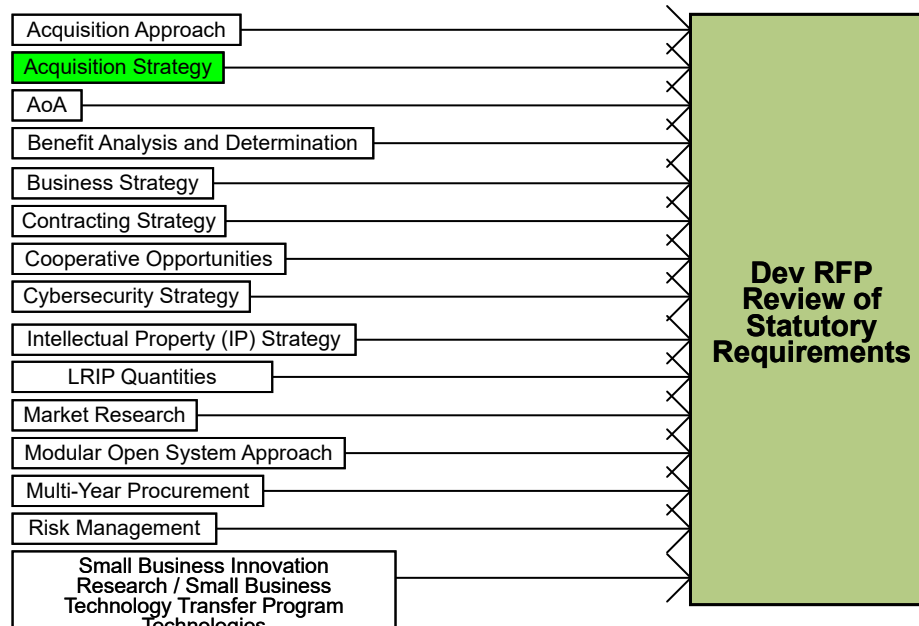

Dev RFP Statutory and Regulatory Information Requirements ACAT I

Dev RFP Statutory and Regulatory Information Requirements ACAT III

Note 1: From DoD 5000.2 Enclosure 1 Statutory & Regulatory Information and Milestone Requirements

Note 2: Click here to access a link to an Air Staff Acquisition Document Coordination Matrix

Note 3: Public Law 114-328 repealed Title 10, Section 2434 effective 23 Dec 2016.

Note 4: Defense Intelligence Threat Library (Threat Modules) is a regulatory requirement with required update every 2 years. DIAD 5000.200 and DIAI 5000.002 are reference documents.

Note 5: Click here for DAU's MDID Tool

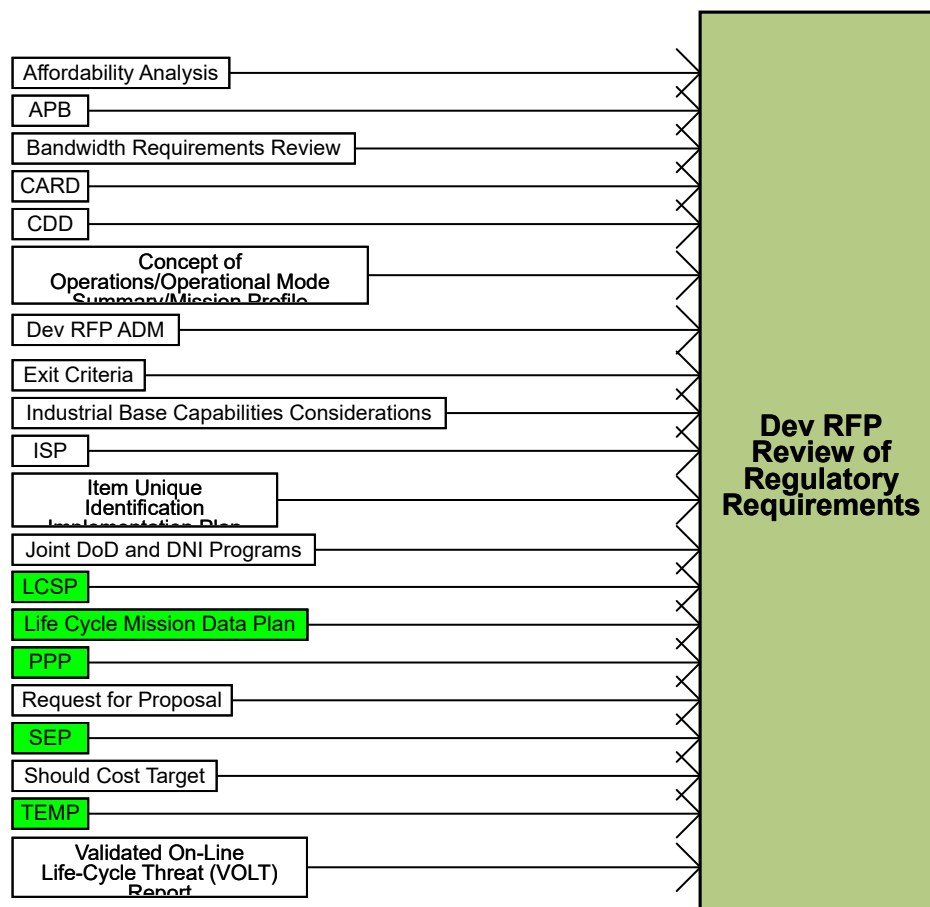

BACK

FWD

Go Up 1 Level

Acquisition Process Model

Enterprise Metrics - ACAT I Programs

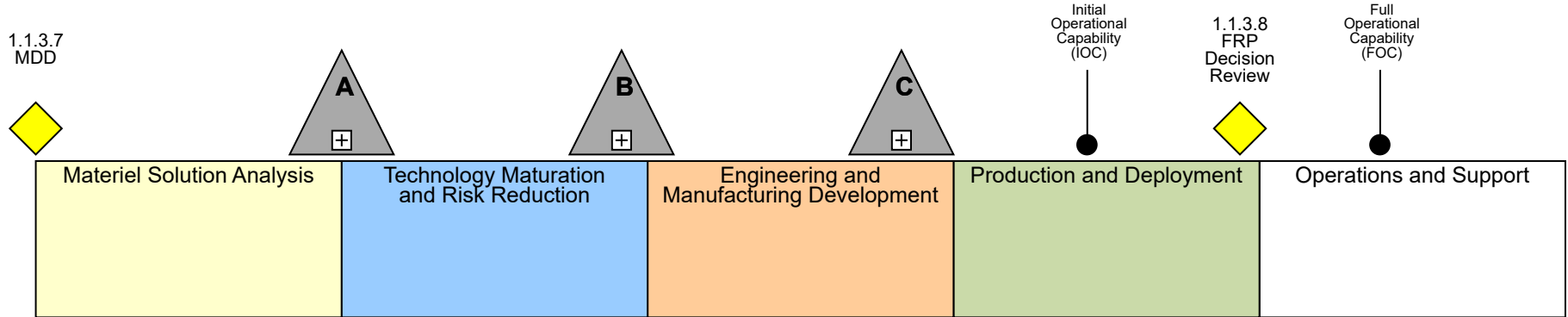

MSB to MSC: Average Estimate 80 months

MSB to IOC: Average Estimate 95 months

MSB to FRP: Average Estimate 122 months

MSC to IOC: Average Estimate 28 months

MSC to FRP: Average Estimate 35 months

Note: The metrics listed above are based on FY17 Q2 Air Force Acquisition Quarterly Performance Assessment (Issued March 2017)

Go Up 1 Level

Acquisition Process Model

Full Rate Production DR Statutory and Regulatory Information Requirements ACAT I

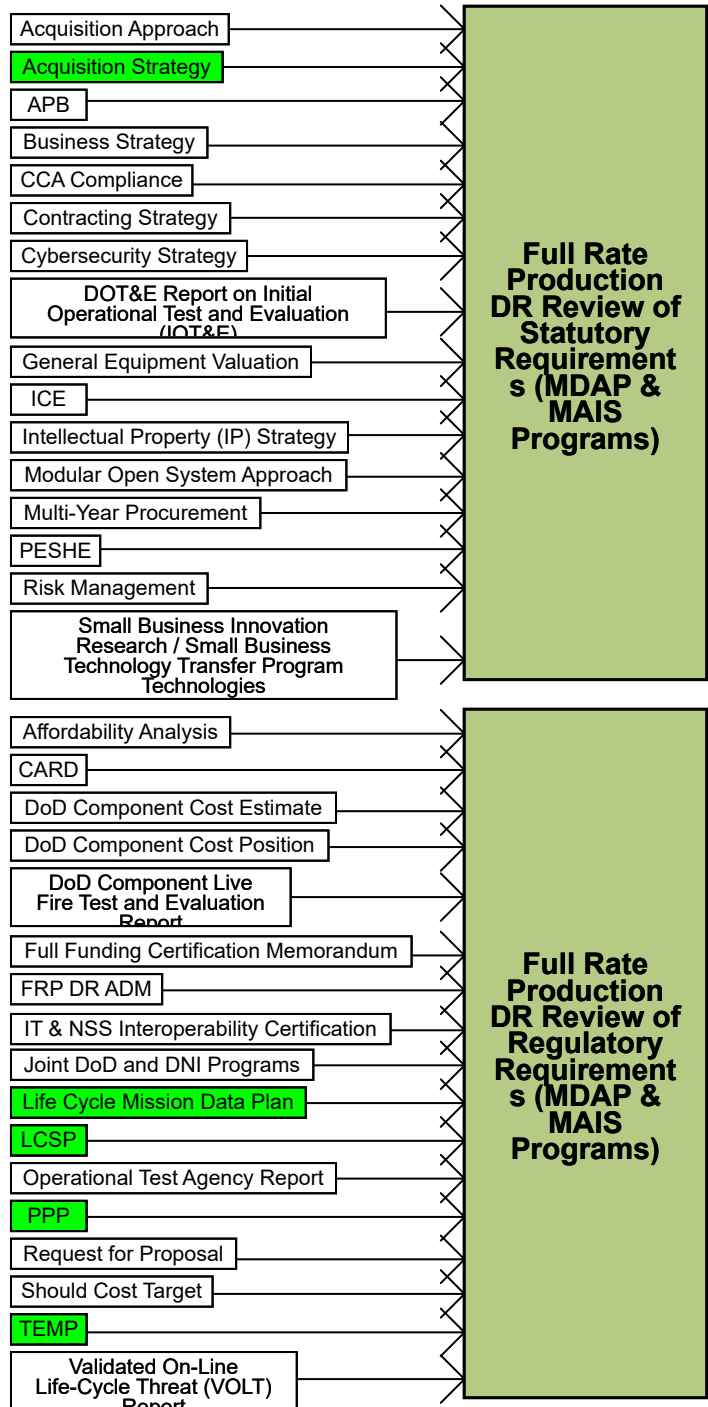

Full Rate Production Statutory and Regulatory Information Requirements ACAT II

Full Rate Production Statutory and Regulatory Information Requirements ACAT III

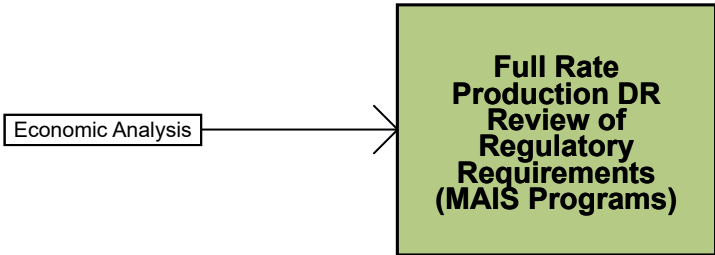
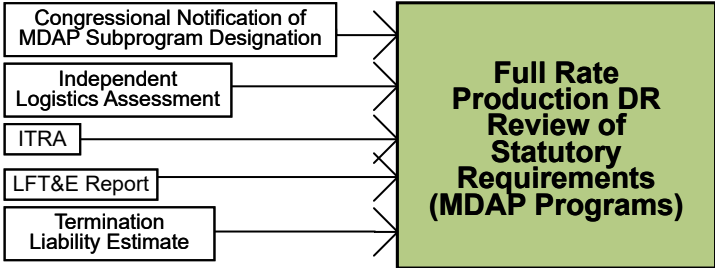

Note 1: From DoD 5000.2 Enclosure 1 Statutory & Regulatory Information and Milestone Requirements

Note 2: Click here to access a link to an Air Staff Acquisition Document Coordination Matrix

Note 3: Public Law 114-328 repealed Title 10, Section 2434 effective 23 Dec 2016.

Note 4: Defense Intelligence Threat Library (Threat Modules) is a regulatory requirement with required update every 2 years. DIAD 5000.200 and DIAI 5000.002 are reference documents.

Note 5: Click here for DAU's MDID Tool

BACK

Go Up 1 Level

Acquisition Process Model

Full Rate Production DR Statutory and Regulatory Information Requirements ACAT II

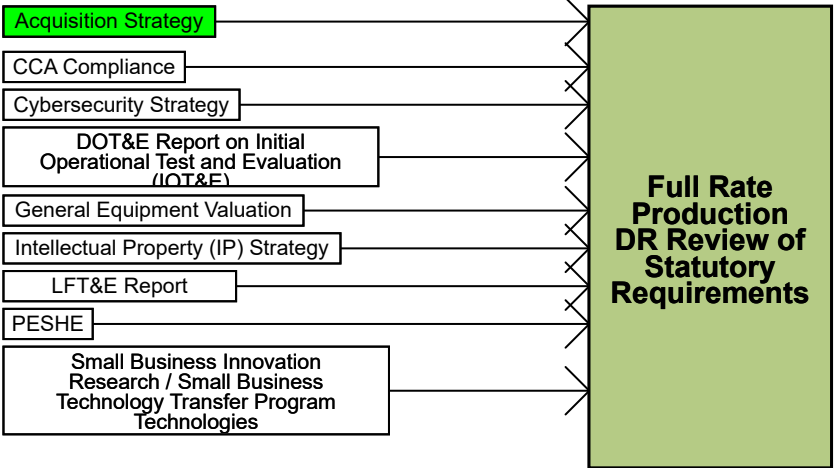

Full Rate Production Statutory and Regulatory Information Requirements ACAT I

Full Rate Production Statutory and Regulatory Information Requirements ACAT III

Note 1: From DoD 5000.2 Enclosure 1 Statutory & Regulatory Information and Milestone Requirements

Note 2: Click here to access a link to an Air Staff Acquisition Document Coordination Matrix

Note 3: Public Law 114-328 repealed Title 10, Section 2434 effective 23 Dec 2016.

Note 4: Defense Intelligence Threat Library (Threat Modules) is a regulatory requirement with required update every 2 years. DIAD 5000.200 and DIAI 5000.002 are reference documents.

Note 5: Click here for DAU's MDID Tool

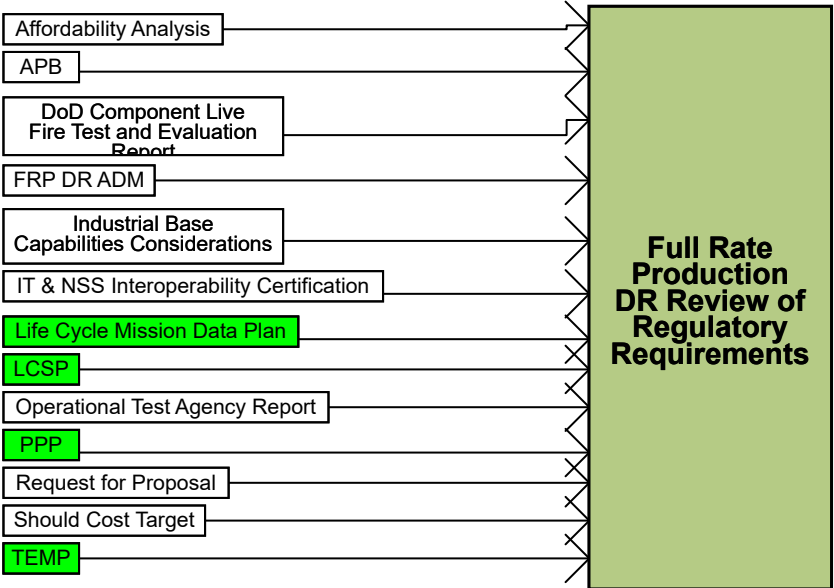

← BACK

Go Up 1 Level

Acquisition Process Model

Full Rate Production DR Statutory and Regulatory Information Requirements ACAT III

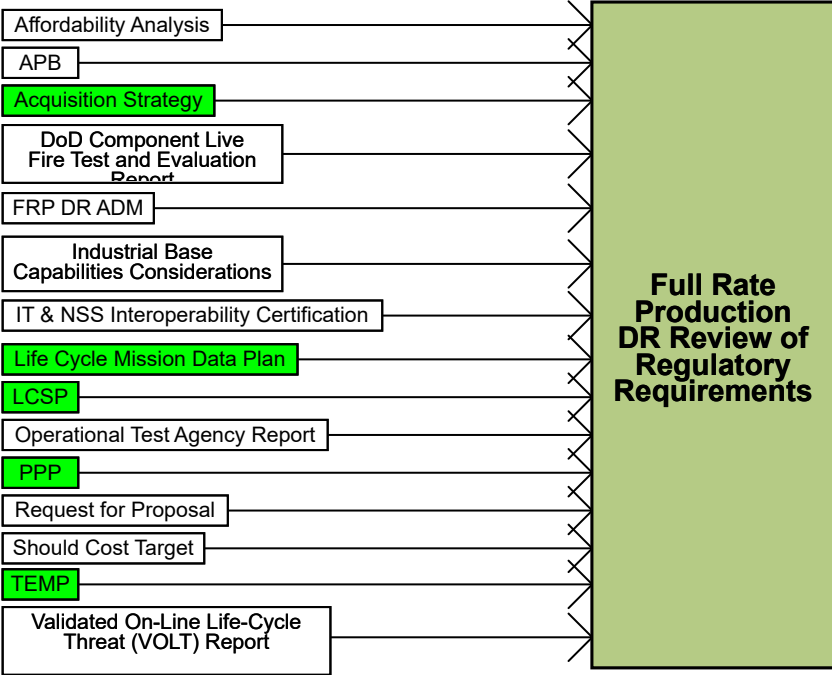
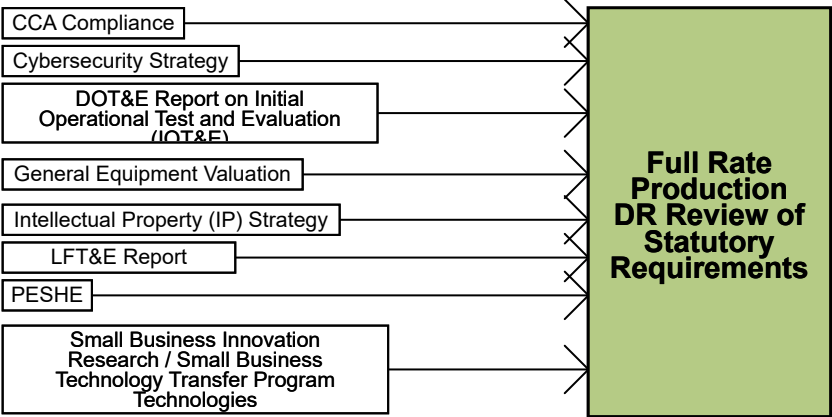

Full Rate Production Statutory and Regulatory Information Requirements ACAT I

Full Rate Production Statutory and Regulatory Information Requirements ACAT II

Note 1: From DoD 5000.2 Enclosure 1 Statutory & Regulatory Information and Milestone Requirements

Note 2: Click here to access a link to an Air Staff Acquisition Document Coordination Matrix

Note 3: Public Law 114-328 repealed Title 10, Section 2434 effective 23 Dec 2016.

Note 4: Defense Intelligence Threat Library (Threat Modules) is a regulatory requirement with required update every 2 years. DIAD 5000.200 and DIAI 5000.002 are reference documents.

Note 5: Click here for DAU's MDID Tool

← BACK

Go Up 1 Level

Acquisition Process Model

Matériel Development Decision (MDD) Regulatory Information Requirements ACAT II

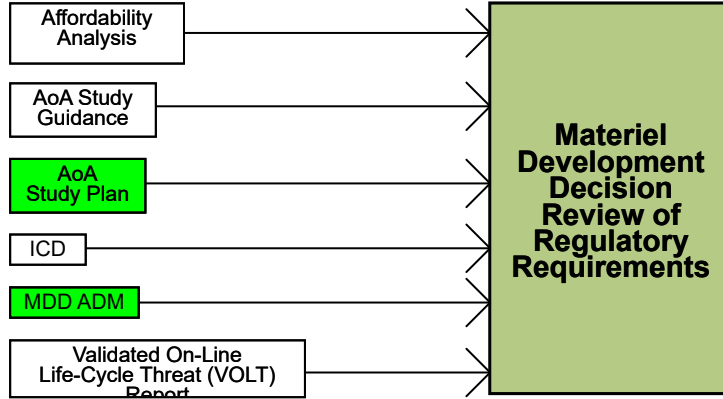

Materiel Development Decision Statutory and Regulatory Information Requirements ACAT I

Materiel Development Decision Regulatory Information Requirements ACAT III

Note 1: From DoD 5000.02 Enclosure 1 Statutory & Regulatory Information and Milestone Requirements

Note 2: Click here to access a link to an Air Staff Acquisition Document Coordination Matrix

Note 3: Click here for DAU's MDID Tool

Note 4: Defense Intelligence Threat Library (Threat Modules) is a regulatory requirement with required update every 2 years. DIAD 5000.200 and DIAI 5000.002 are reference documents.

FWD

Go Up 1 Level

Acquisition Process Model

Material Development Decision (MDD) Regulatory Information Requirements ACAT III

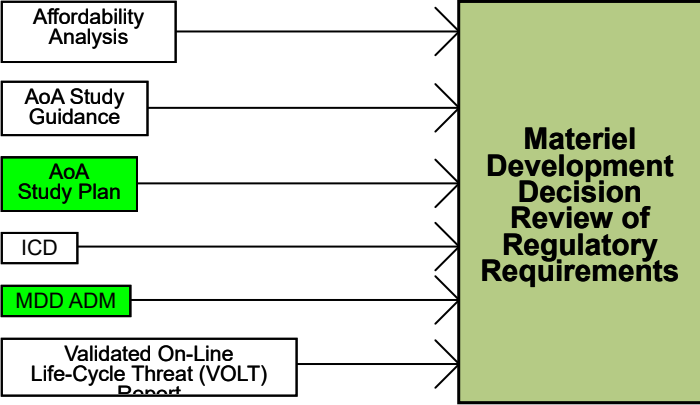

Material Development Decision
Statutory and Regulatory Requirements
ACAT I

Material Development Decision
Regulatory Information Requirements
ACAT II

Note 1: From DoD 5000.02 Enclosure 1 Statutory & Regulatory Information and Milestone Requirements

Note 2: Click here to access a link to an Air Staff Acquisition Document Coordination Matrix

Note 3: Click here for DAU's MDID Tool

Note 4: Defense Intelligence Threat Library (Threat Modules) is a regulatory requirement with required update every 2 years. DIAD 5000.200 and DIAI 5000.002 are reference documents.

FWD

Acquisition Process Model

Materiel Development Decision (MDD) Statutory and Regulatory Information Requirements ACAT I

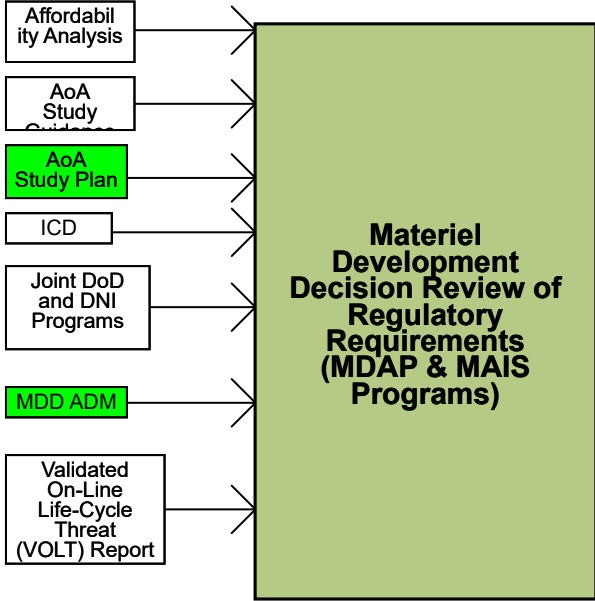
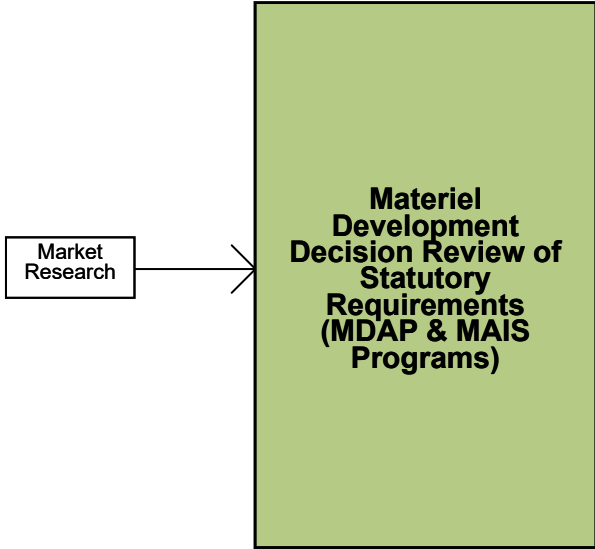

Materiel Development Decision
Regulatory Information Requirements
ACAT II

Materiel Development Decision
Regulatory Information Requirements
ACAT III

Note 1: From DoD 5000.02 Enclosure 1 Statutory & Regulatory Information and Milestone Requirements

Note 2: Click here to access a link to an Air Staff Acquisition Document Coordination Matrix

Note 3: Click here for DAU's MDID Tool

Note 4: Defense Intelligence Threat Library (Threat Modules) is a regulatory requirement with required update every 2 years. DIAD 5000.200 and DIAI 5000.002 are reference documents.

FWD →

Go Up 1 Level

Acquisition Process Model

Milestone A Statutory and Regulatory Information Requirements ACAT I

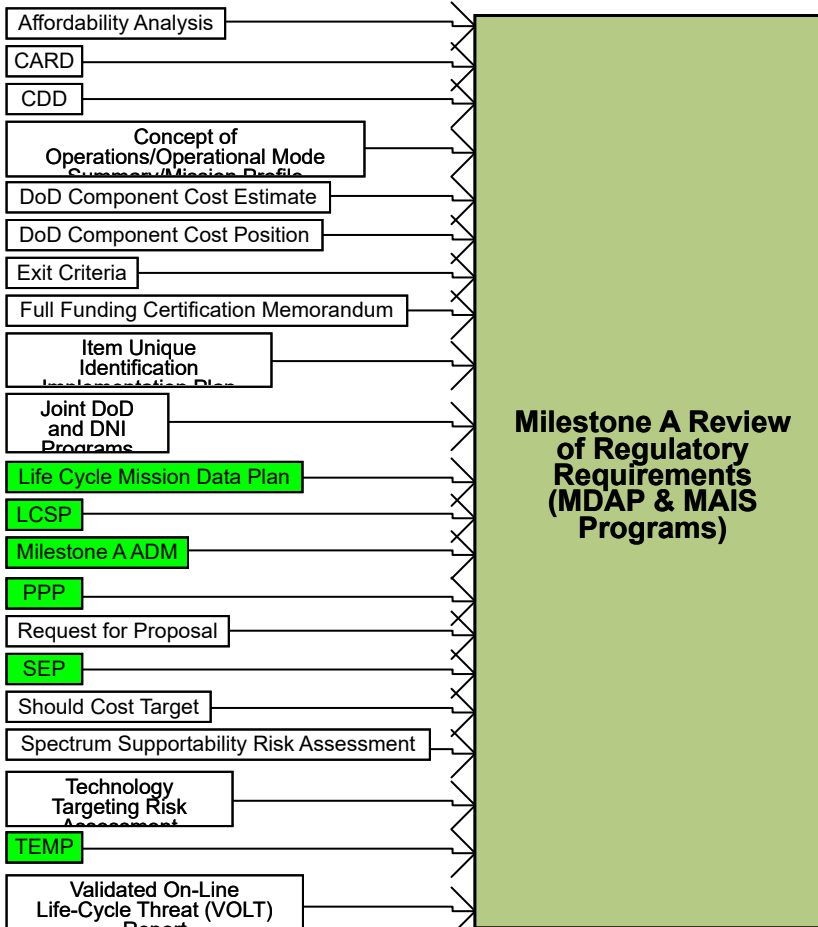
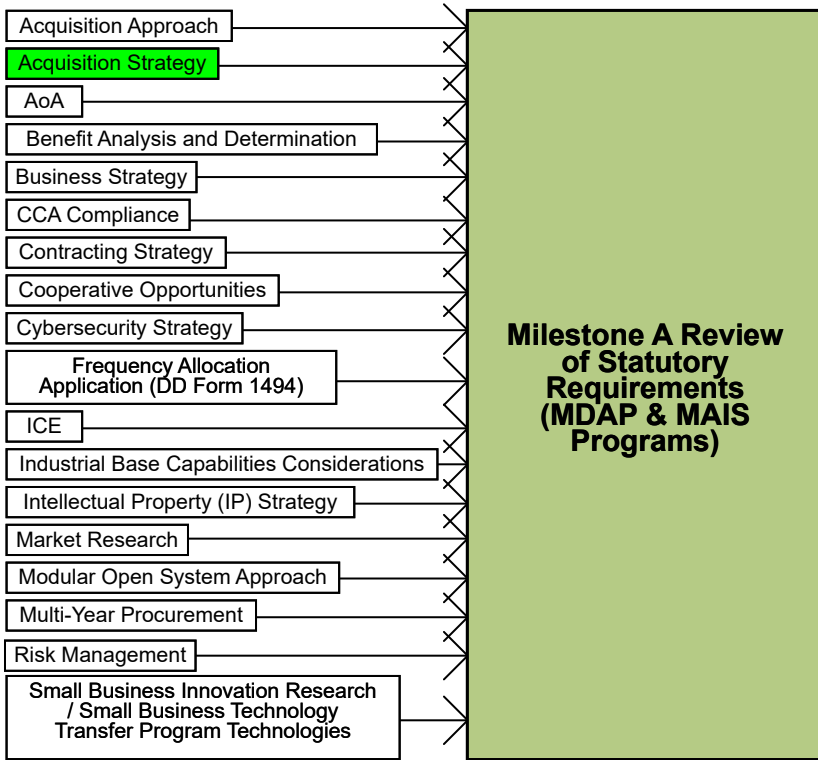

Milestone A Statutory and Regulatory Information Requirements ACAT II

Milestone A Statutory and Regulatory Information Requirements ACAT III

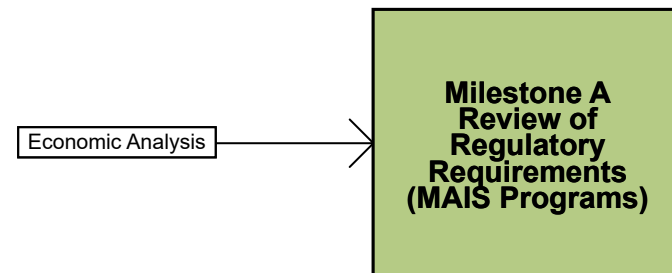
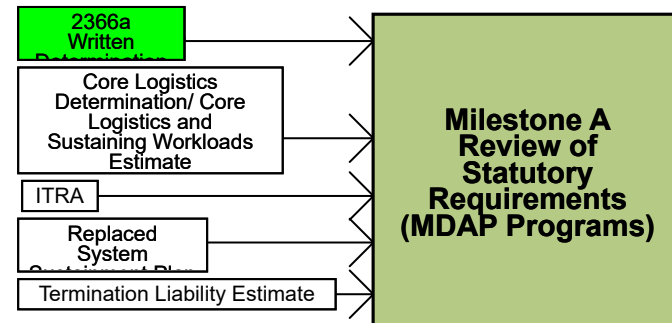

Note 1: DoD 5000.02 Enclosure 1 Statutory & Regulatory Information and Milestone Requirements

Note 2: Click here to access a link to an Air Staff Acquisition Document Coordination Matrix

Note 3: Public Law 114-328 repealed Title 10, Section 2434 effective 23 Dec 2016.

Note 4: Defense Intelligence Threat Library (Threat Modules) is a regulatory requirement with required update every 2 years. DIAD 5000.200 and DIAI 5000.002 are reference documents.

Note 5: Click here for DAU's MDID Tool

Note 6: ITRAs are effective immediately; they will be incorporated into the next version of DoD Instruction (DoDI) 5000.02 per Policy Memorandum for Independent Technical Risk Assessment dated 18 Jun 2018.

Go Up 1 Level

Acquisition Process Model

Milestone A Statutory and Regulatory Information Requirements ACAT II

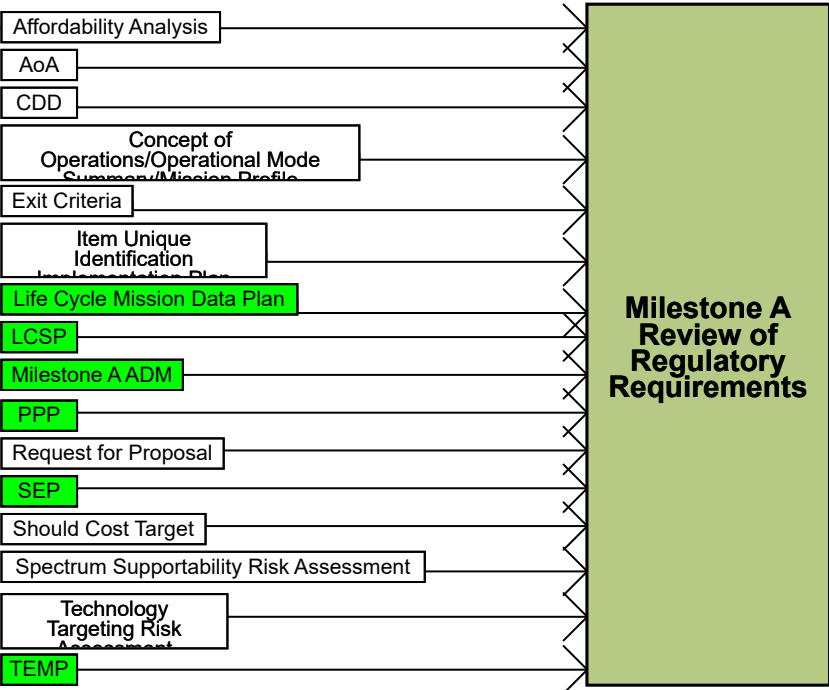
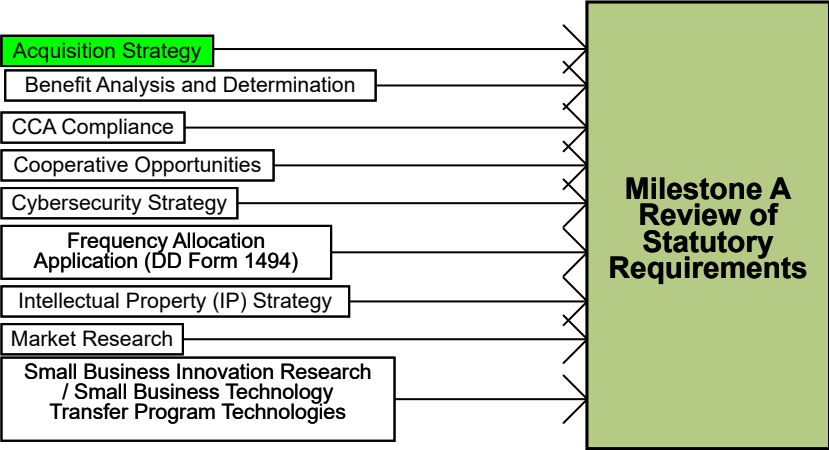

Milestone A Statutory and Regulatory Information Requirements ACAT I

Milestone A Statutory and Regulatory Information Requirements ACAT III

Note 1: DoD 5000.02 Enclosure 1 Statutory & Regulatory Information and Milestone Requirements

Note 2: Click here to access a link to an Air Staff Acquisition Document Coordination Matrix

Note 3: Public Law 114-328 repealed Title 10, Section 2434 effective 23 Dec 2016.

Note 4: Defense Intelligence Threat Library (Threat Modules) is a regulatory requirement with required update every 2 years. DIAD 5000.200 and DIAI 5000.002 are reference documents.

Note 5: Click here for DAU's MDID Tool

← BACK FWD →

Go Up 1 Level

Acquisition Process Model

Milestone A Statutory and Regulatory Information Requirements ACAT III

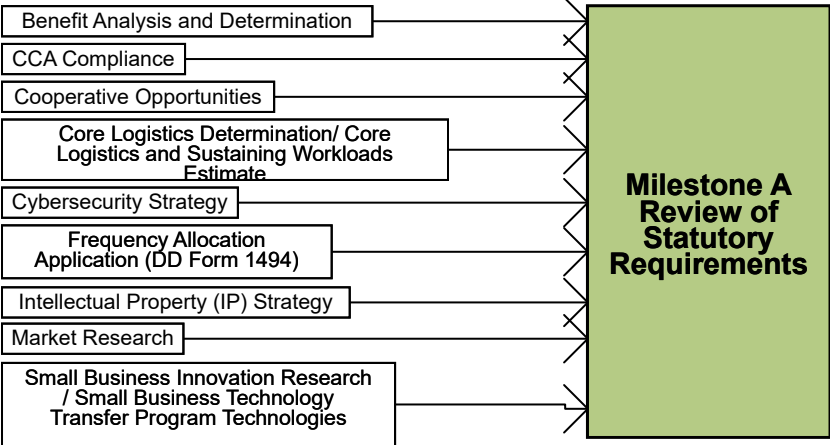

Milestone A Statutory and Regulatory Information Requirements ACAT I

Milestone A Statutory and Regulatory Information Requirements ACAT II

Note 1: From DoD 5000.2 Enclosure 1 Statutory & Regulatory Information and Milestone Requirements

Note 2: Click here to access a link to an Air Staff Acquisition Document Coordination Matrix

Note 3: Public Law 114-328 repealed Title 10, Section 2434 effective 23 Dec 2016.

Note 4: Defense Intelligence Threat Library (Threat Modules) is a regulatory requirement with required update every 2 years. DIAD 5000.200 and DIAI 5000.002 are reference documents.

Note 5: Click here for DAU's MDID Tool

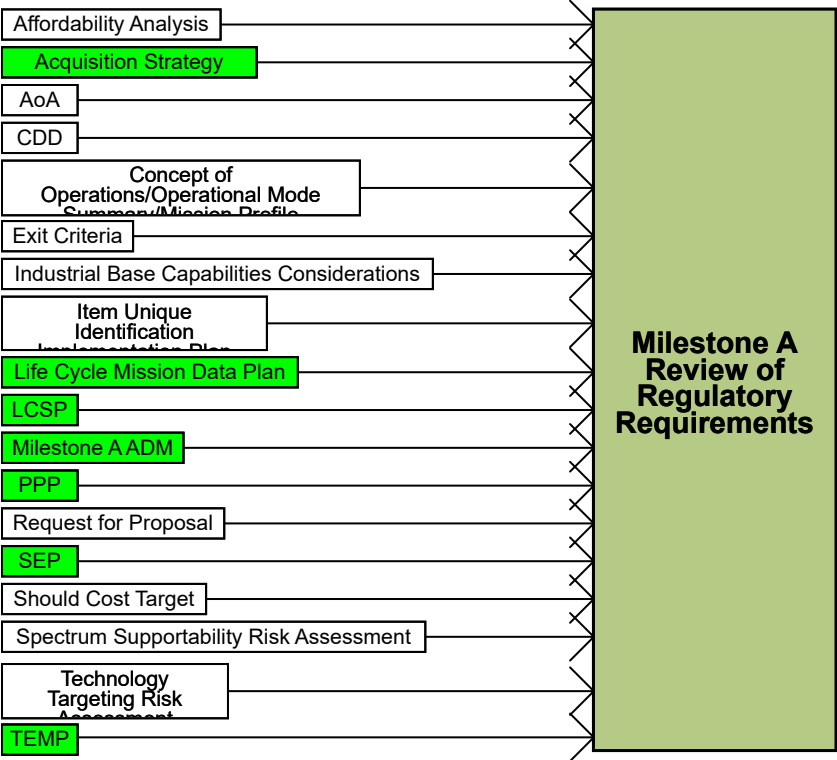

BACK

FWD

Acquisition Process Model

Milestone B Statutory and Regulatory Information Requirements ACAT I

Go Up 1 Level

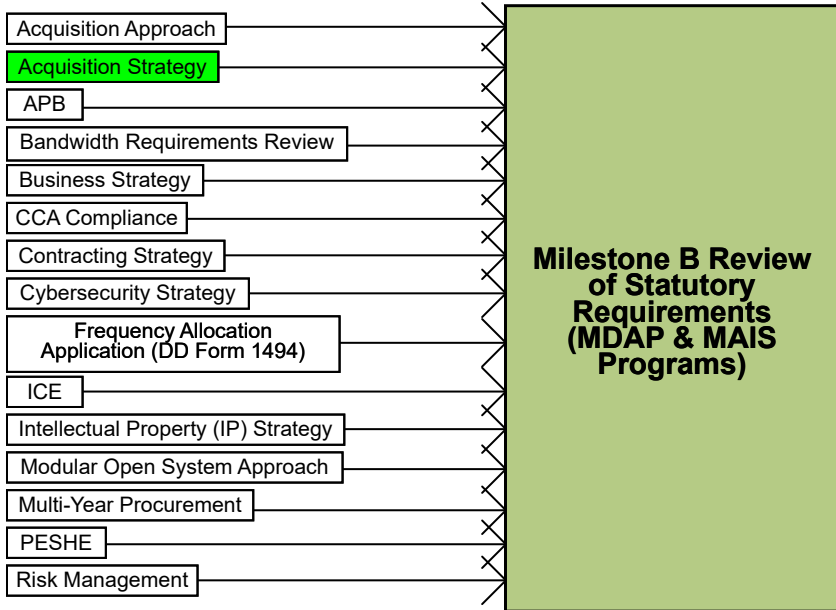

Milestone B Statutory and Regulatory Information Requirements ACAT II

Milestone B Statutory and Regulatory Information Requirements ACAT III

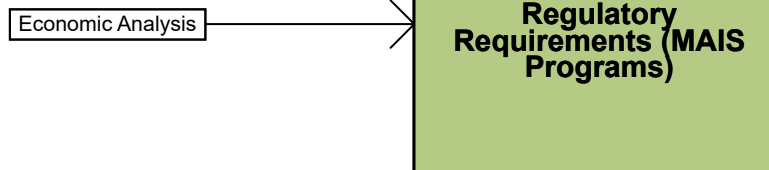
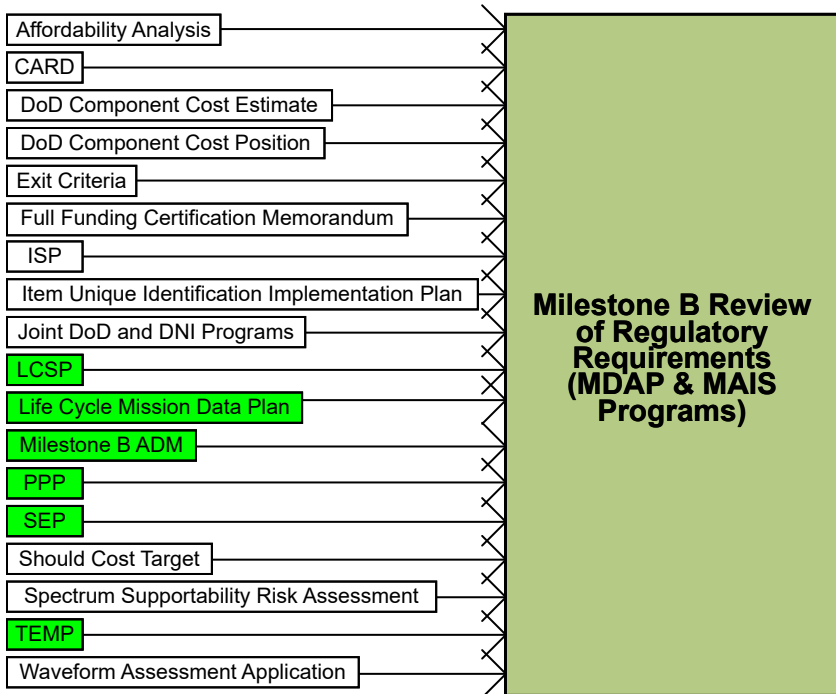
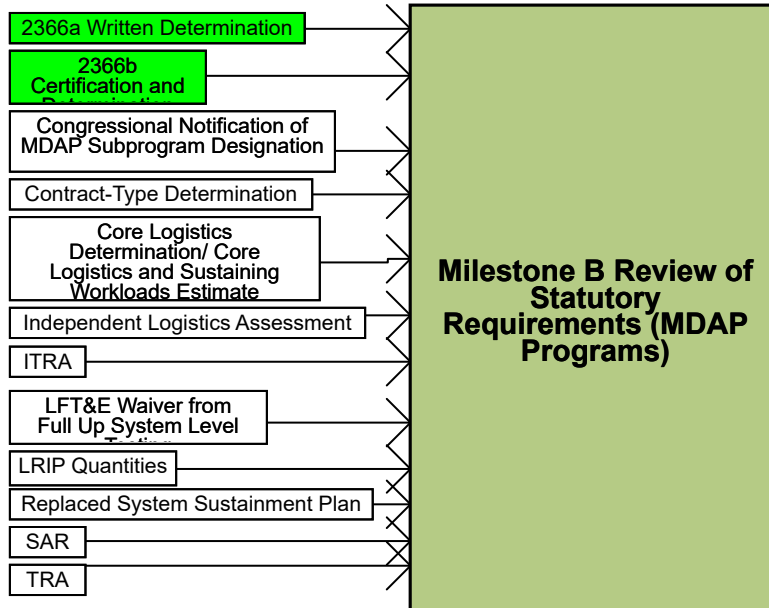

Note 1: From DoD 5000.2 Enclosure 1 Statutory & Regulatory Information and Milestone Requirements

Note 2: Click here to access a link to an Air Staff Acquisition Document Coordination Matrix

Note 3: Public Law 114-328 repealed Title 10, Section 2434 effective 23 Dec 2016.

Note 4: Defense Intelligence Threat Library (Threat Modules) is a regulatory requirement with required update every 2 years. DIAD 5000.200 and DIAI 5000.002 are reference documents.

Note 5: Click here for DAU's MDID Tool

Note 6: ITRAs are effective immediately; they will be incorporated into the next version of DoD Instruction (DoDI) 5000.02 per Policy Memorandum for Independent Technical Risk Assessment dated 18 Jun 2018.

Go Up 1 Level

Acquisition Process Model

Milestone B Statutory and Regulatory Information Requirements ACAT II

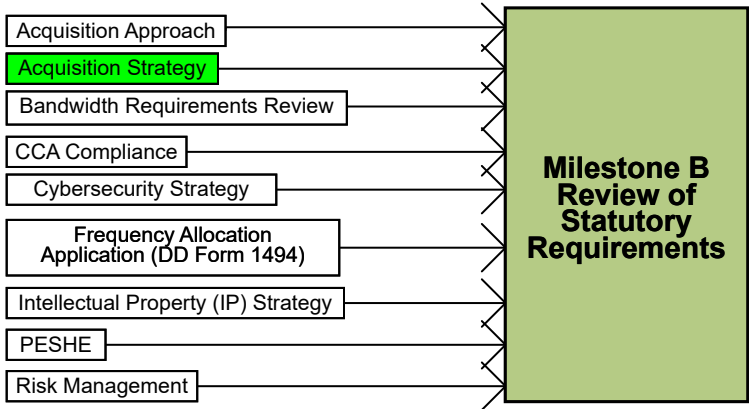

Milestone B Statutory and Regulatory Information Requirements ACAT I

Milestone B Statutory and Regulatory Information Requirements ACAT III

Note 1: From DoD 5000.2 Enclosure 1 Statutory & Regulatory Information and Milestone Requirements

Note 2: Click here to access a link to an Air Staff Acquisition Document Coordination Matrix

Note 3: Public Law 114-328 repealed Title 10, Section 2434 effective 23 Dec 2016.

Note 4: Defense Intelligence Threat Library (Threat Modules) is a regulatory requirement with required update every 2 years. DIAD 5000.200 and DIAI 5000.002 are reference documents.

Note 5: Click here for DAU's MDID Tool

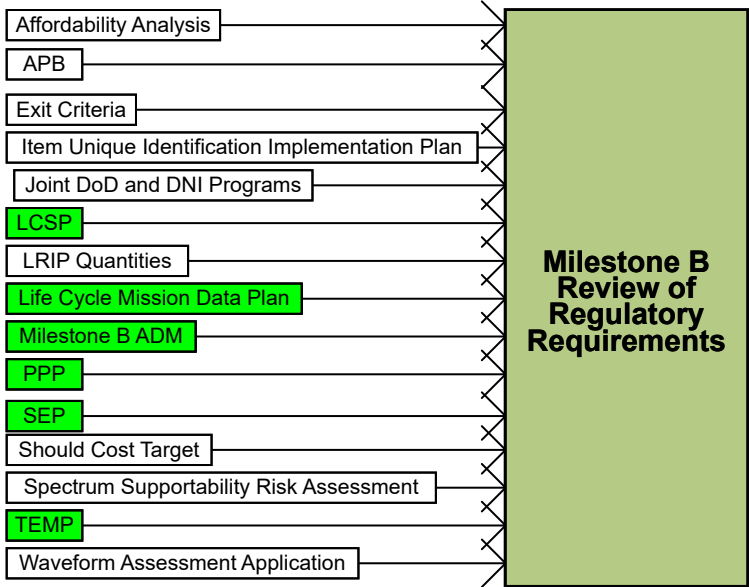

BACK

FWD

Go Up 1 Level

Acquisition Process Model

Milestone B Statutory and Regulatory Information Requirements ACAT III

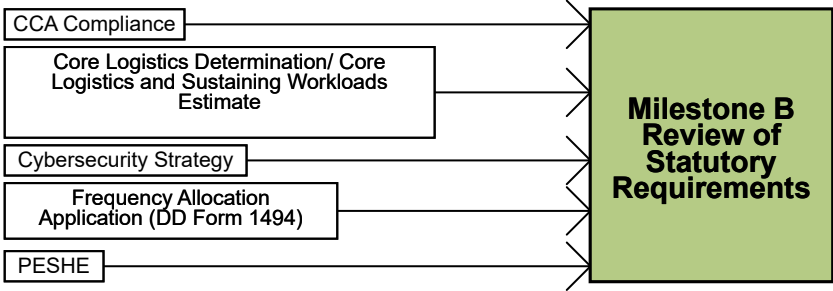

Milestone B Statutory and Regulatory Information Requirements ACAT I

Milestone B Statutory and Regulatory Information Requirements ACAT II

Note 1: From DoD 5000.2 Enclosure 1 Statutory & Regulatory Information and Milestone Requirements

Note 2: Click here to access a link to an Air Staff Acquisition Document Coordination Matrix

Note 3: Public Law 114-328 repealed Title 10, Section 2434 effective 23 Dec 2016.

Note 4: Defense Intelligence Threat Library (Threat Modules) is a regulatory requirement with required update every 2 years. DIAD 5000.200 and DIAI 5000.002 are reference documents.

Note 5: Click here for DAU's MDID Tool

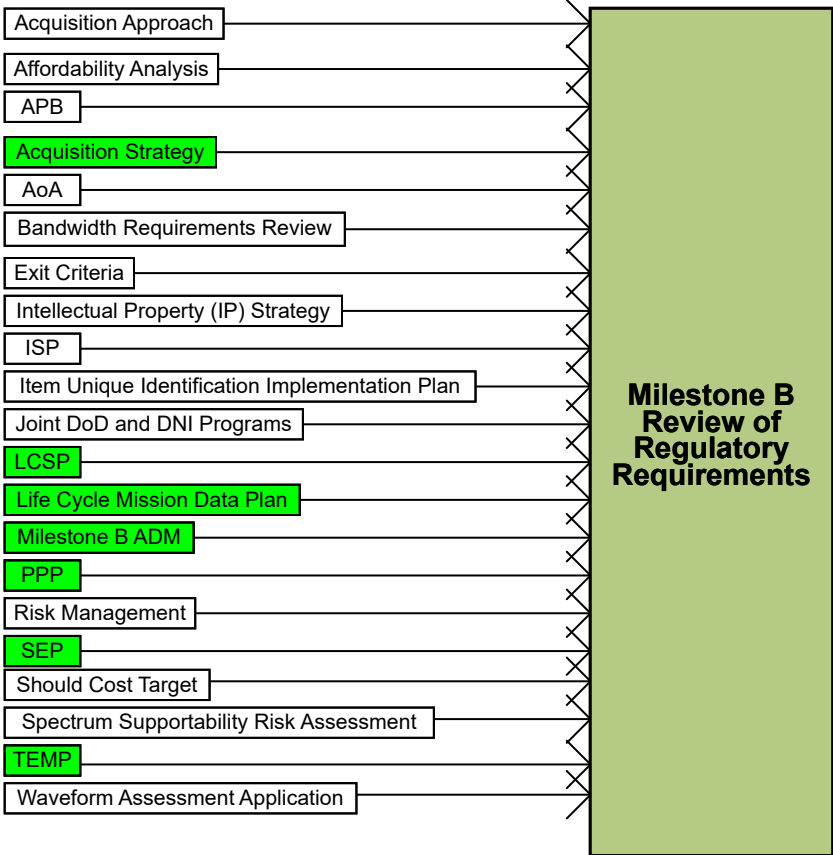

← BACK

FWD →

Go Up 1 Level

Acquisition Process Model

Milestone C Statutory and Regulatory Information Requirements ACAT I

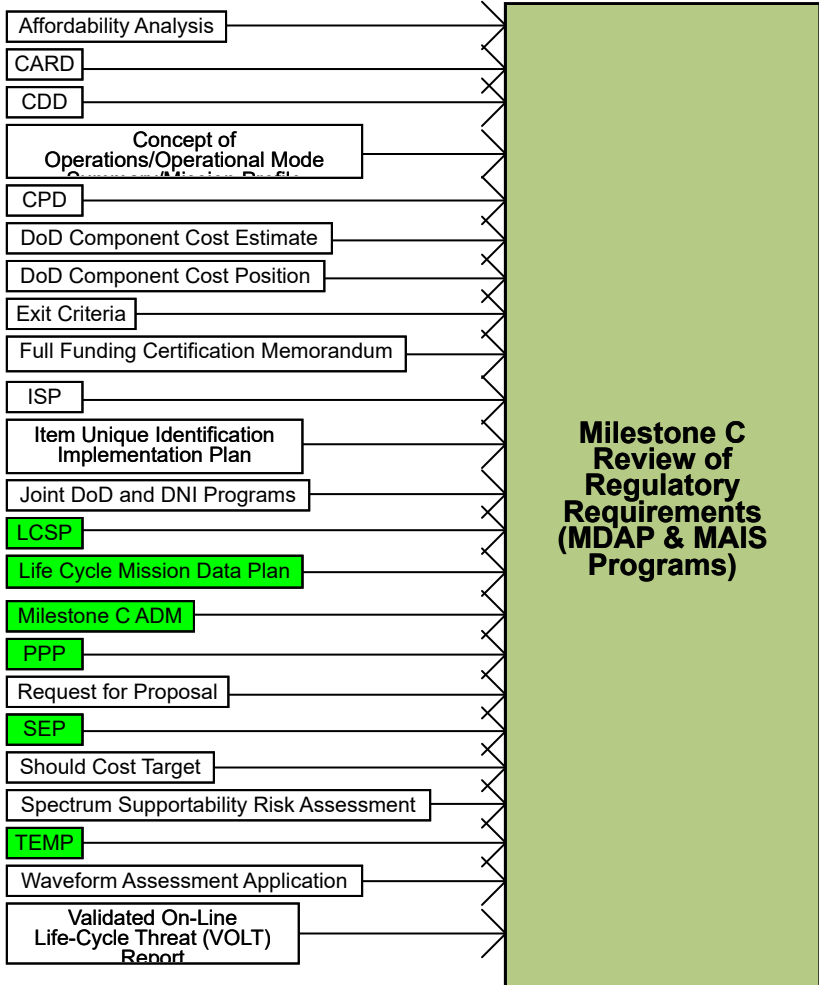
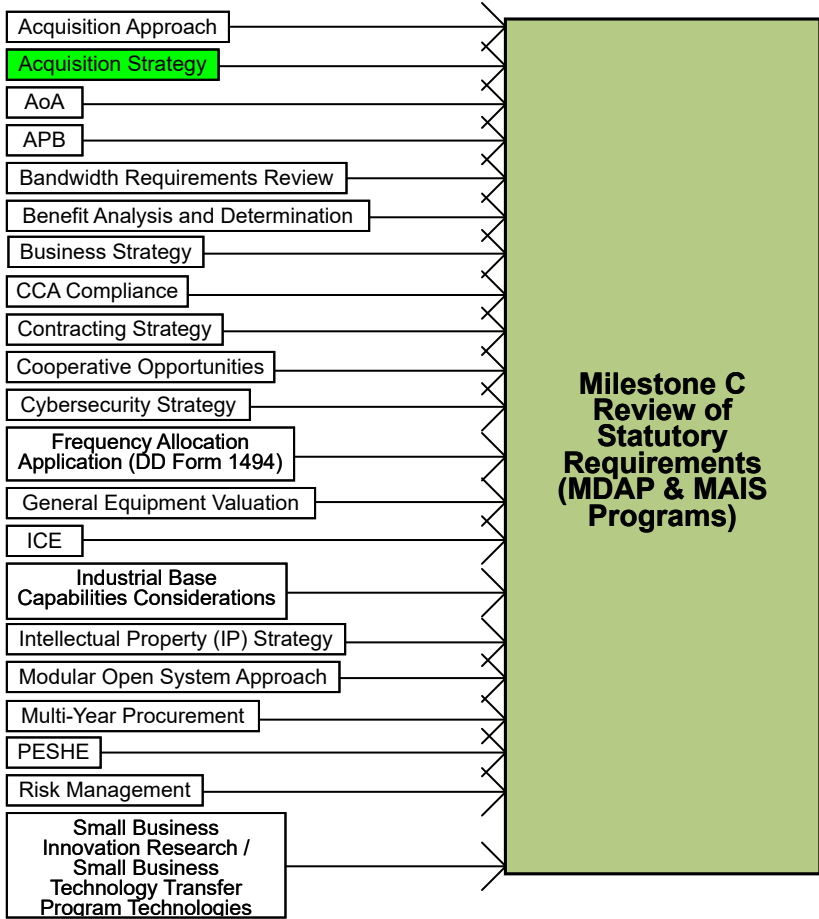

Milestone C Statutory and Regulatory Information Requirements ACAT II

Milestone C Statutory and Regulatory Information Requirements ACAT III

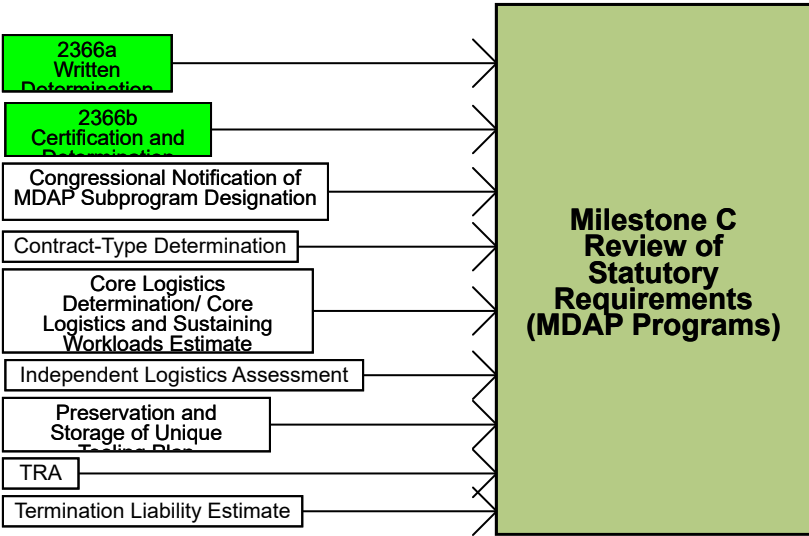

Note 1: From DoD 5000.2 Enclosure 1 Statutory & Regulatory Information and Milestone Requirements

Note 2: Click here to access a link to an Air Staff Acquisition Document Coordination Matrix

Note 3: Public Law 114-328 repealed Title 10, Section 2434 effective 23 Dec 2016.

Note 4: Defense Intelligence Threat Library (Threat Modules) is a regulatory requirement with required update every 2 years. DIAD 5000.200 and DIAI 5000.002 are reference documents.

Note 5: Click here for DAU's MDID Tool

Go Up 1 Level

Acquisition Process Model

Milestone C Statutory and Regulatory Information Requirements ACAT II

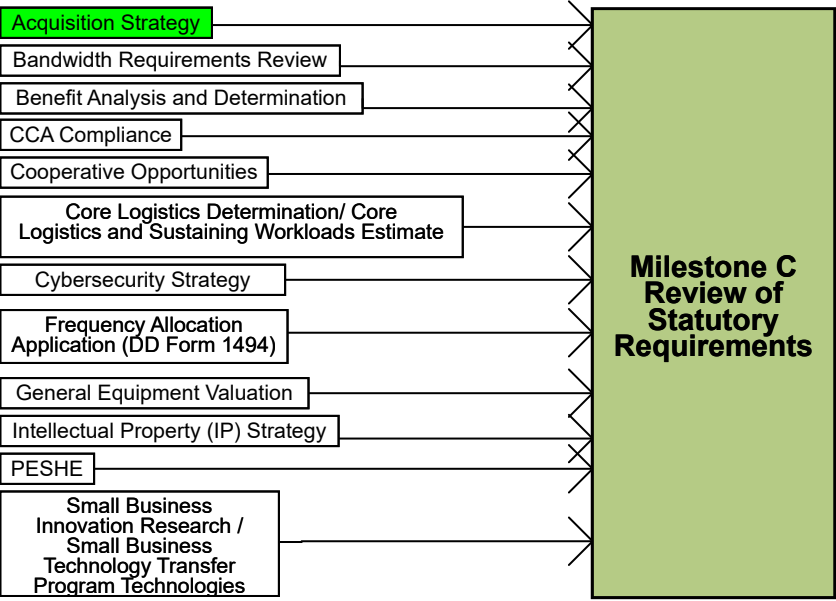

Milestone C Statutory and Regulatory Information Requirements ACAT I

Milestone C Statutory and Regulatory Information Requirements ACAT III

Note 1: From DoD 5000.2 Enclosure 1 Statutory & Regulatory Information and Milestone Requirements

Note 2: Click here to access a link to an Air Staff Acquisition Document Coordination Matrix

Note 3: Public Law 114-328 repealed Title 10, Section 2434 effective 23 Dec 2016.

Note 4: Defense Intelligence Threat Library (Threat Modules) is a regulatory requirement with required update every 2 years. DIAD 5000.200 and DIAI 5000.002 are reference documents.

Note 5: Click here for DAU's MDID Tool

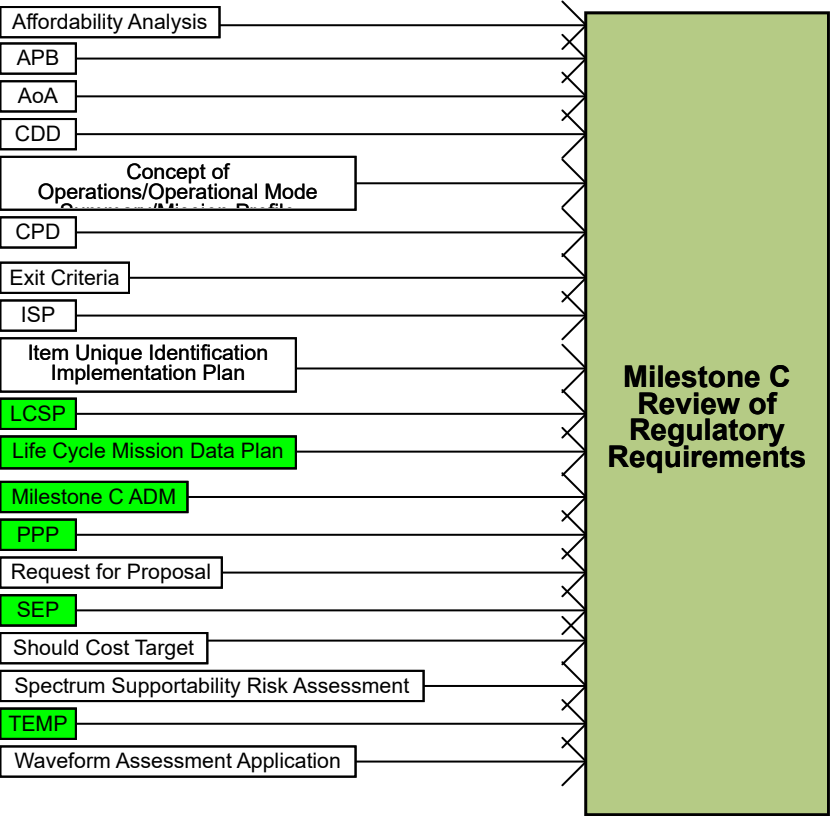

BACK

FWD

Go Up 1 Level

Acquisition Process Model

Milestone C Statutory and Regulatory Information Requirements ACAT III

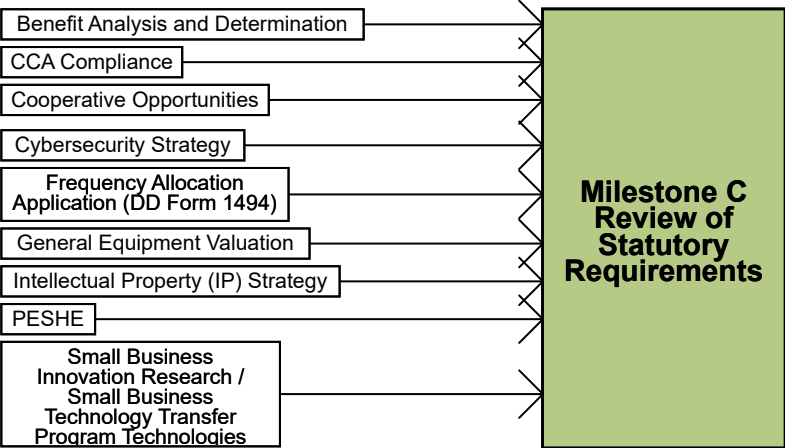

Milestone C Statutory and Regulatory Information Requirements ACAT I

Milestone C Statutory and Regulatory Information Requirements ACAT II

Note 1: From DoD 5000.2 Enclosure 1 Statutory & Regulatory Information and Milestone Requirements

Note 2: Click here to access a link to an Air Staff Acquisition Document Coordination Matrix

Note 3: Public Law 114-328 repealed Title 10, Section 2434 effective 23 Dec 2016.

Note 4: Defense Intelligence Threat Library (Threat Modules) is a regulatory requirement with required update every 2 years. DIAD 5000.200 and DIAI 5000.002 are reference documents.

Note 5: Click here for DAU's MDID Tool

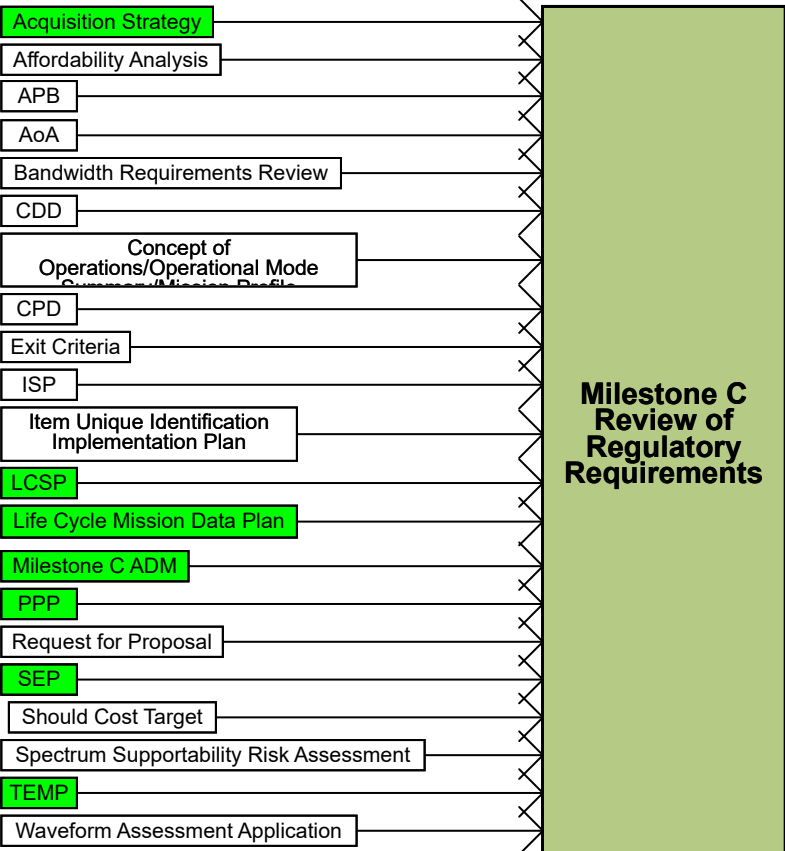

← BACK

FWD →

Go Up 1 Level

Acquisition Process Model

Milestone Information Requirements

ACAT I

- Materiel Development Decision Statutory & Regulatory Information Requirements ACAT I
- Milestone A Statutory & Regulatory Information Requirements ACAT I
- Dev RFP Statutory & Regulatory Information Requirements ACAT I
- Milestone B Statutory & Regulatory Information Requirements ACAT I
- Milestone C Statutory & Regulatory Information Requirements ACAT I
- Full Rate Production Statutory & Regulatory Information Requirements ACAT I

ACAT II

- Materiel Development Decision Regulatory Information Requirements ACAT II
- Milestone A Statutory & Regulatory Information Requirements ACAT II
- Dev RFP Statutory & Regulatory Information Requirements ACAT II
- Milestone B Statutory & Regulatory Information Requirements ACAT II
- Milestone C Statutory & Regulatory Information Requirements ACAT II
- Full Rate Production Statutory & Regulatory Information Requirements ACAT II

ACAT III

- Materiel Development Decision Regulatory Information Requirements ACAT III
- Milestone A Statutory & Regulatory Information Requirements ACAT III
- Dev RFP Statutory & Regulatory Information Requirements ACAT III
- Milestone B Statutory & Regulatory Information Requirements ACAT III
- Milestone C Statutory & Regulatory Information Requirements ACAT III
- Full Rate Production Statutory & Regulatory Information Requirements ACAT III

Acquisition Process Model

PEO View

AFLCMC Standard Processes

Go Up 1 Level

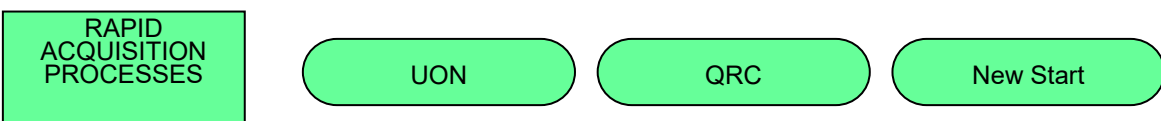
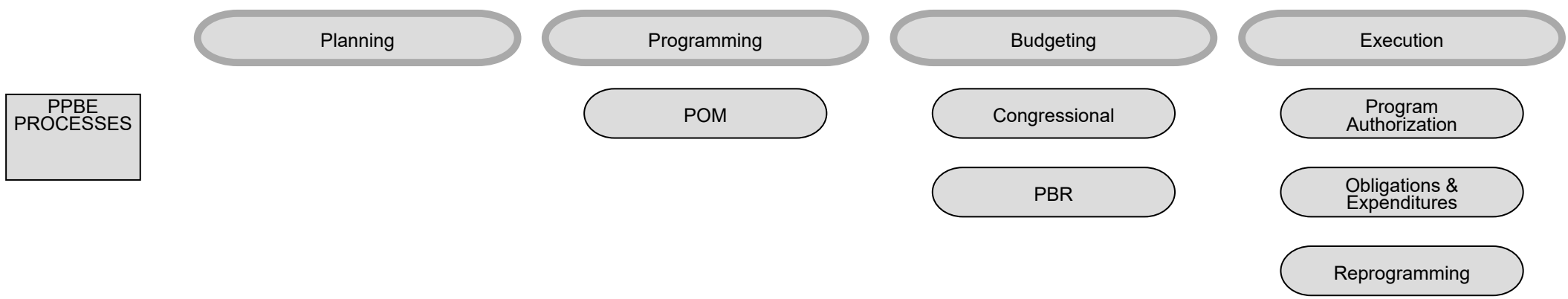
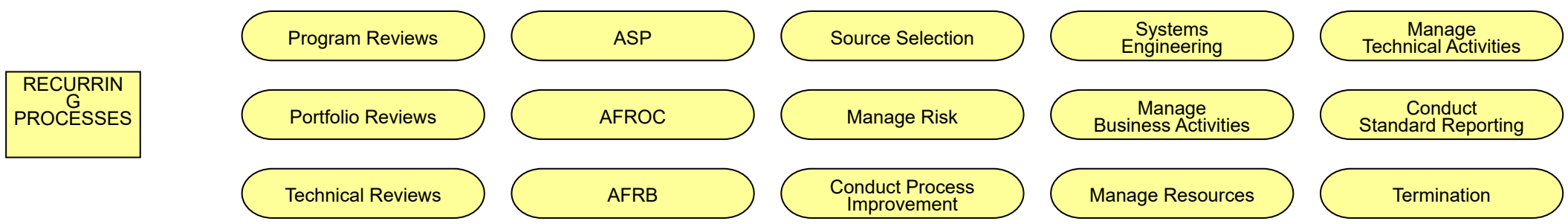
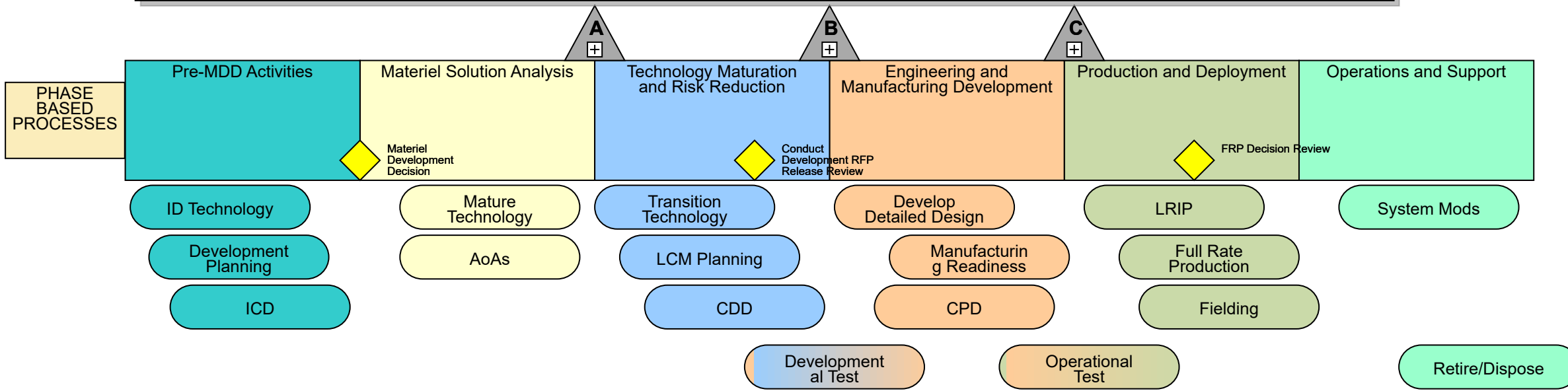

Note: Program Integration provides the AF with consistent insightful and synchronized recommendations, improved data reporting and analysis, and maximized utilization of resources. The objective is to strengthen decision-making across AF Acquisition leadership.

Acquisition Process Model

Program Reviews (MS A to MS B)

MS A

MS B

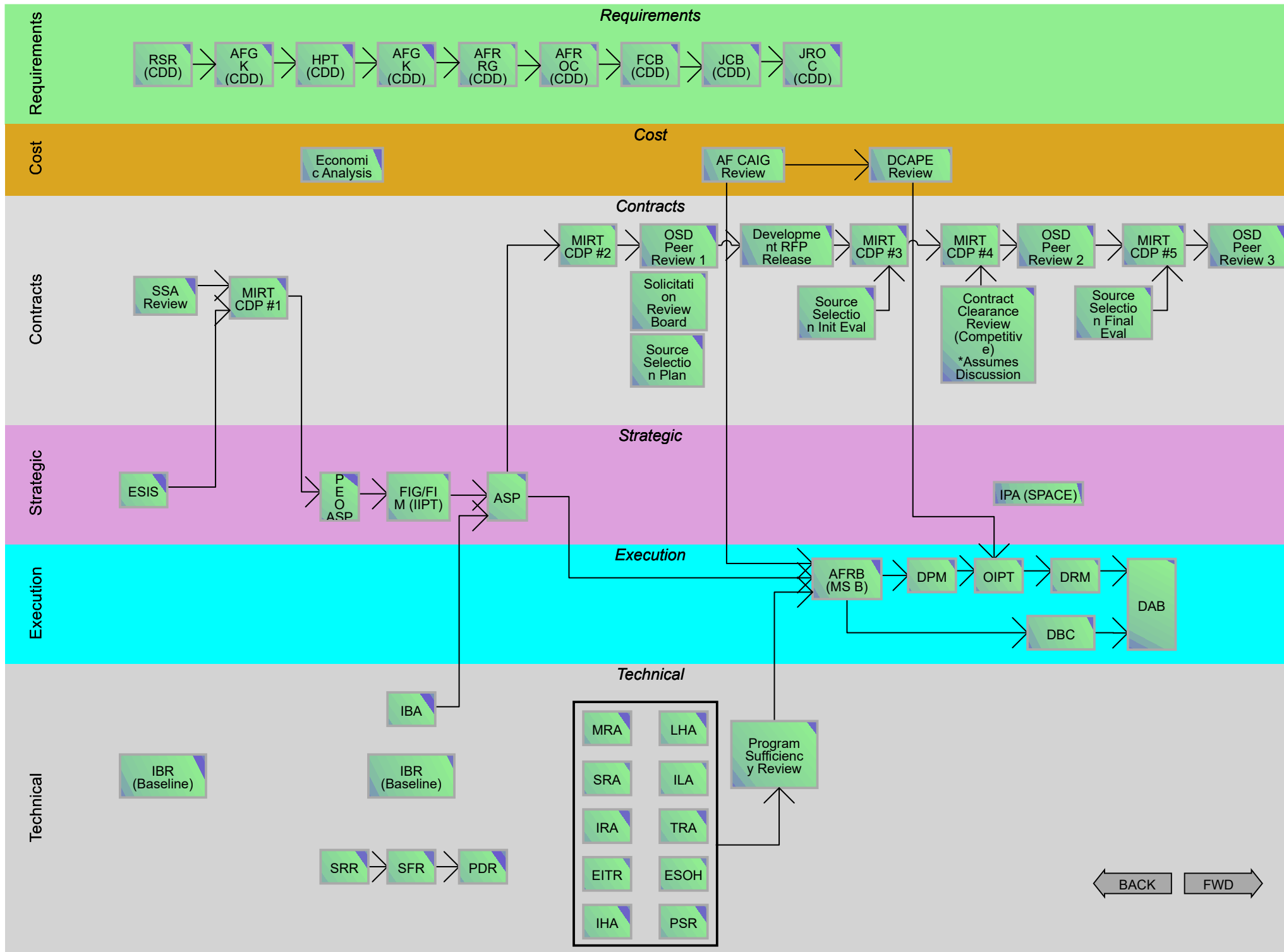

- Other Non-Milestone Related Reviews**
- Acq/Sust Review
 - SPR/IBR
 - SEAM
 - CSB
 - Staffer Day Brief
 - Audits/Inspections
 - PEO Portfolio Review
 - SAE Monthly Review
 - ILCM Executive Forum
 - DAES Reviews
 - Program Management Reviews
 - AFRB MS B (Out of Cycle)
 - DAO Review

← BACK FWD →

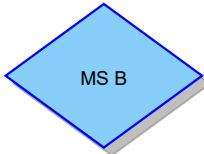

Acquisition Process Model

Program Reviews (MS B to MS C)

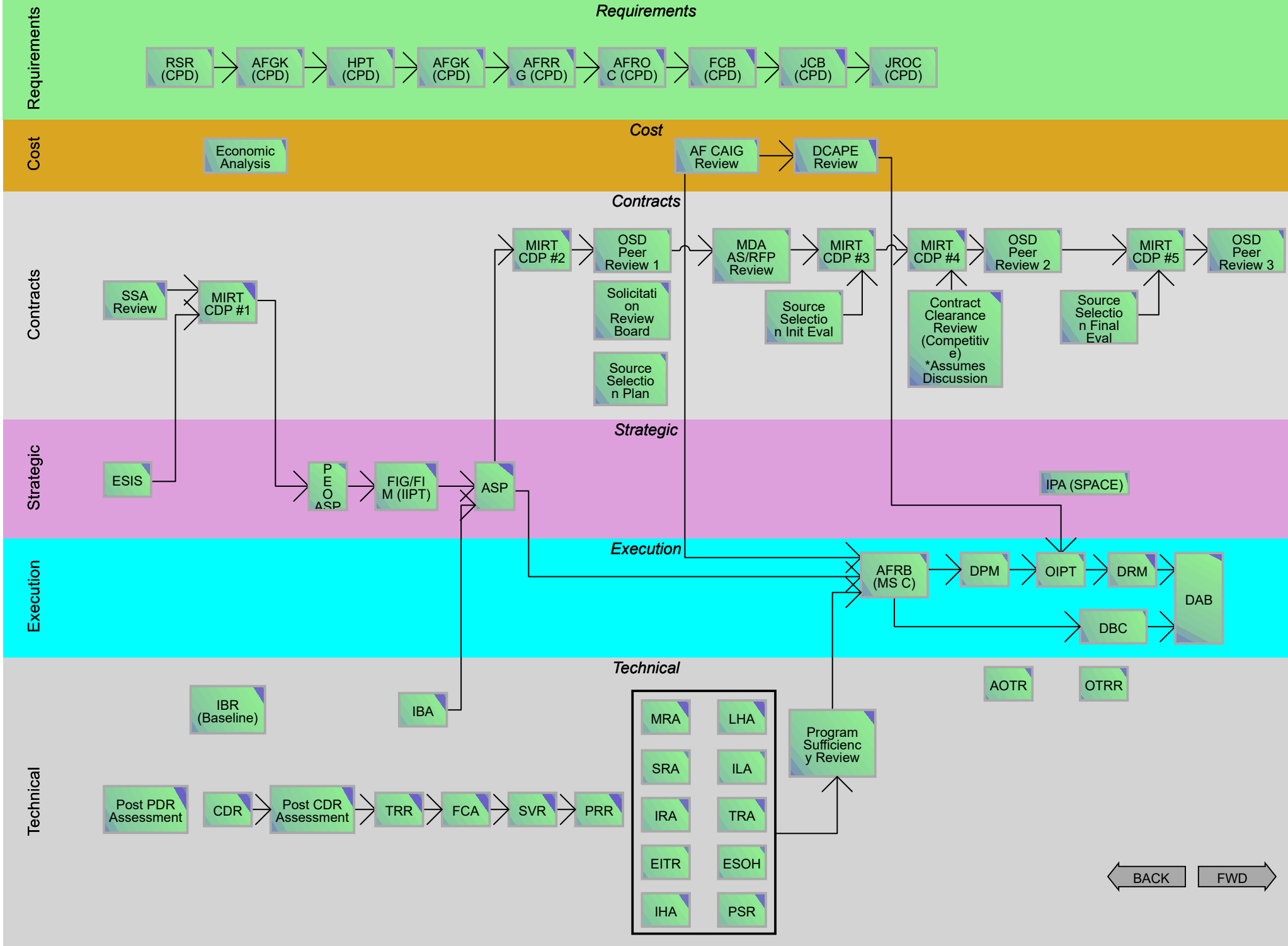
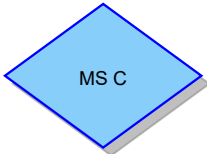

- Other Non-Milestone Related Reviews**
- Acq/Sust Review
 - SPR/IBR
 - SEAM
 - CSB
 - Staffer Day Brief
 - Audits/Inspections
 - PEO Portfolio Review
 - SAE Monthly Review
 - ILCM Executive Forum
 - DAES Reviews
 - Program Management Reviews
 - AFRB MS C (Out of Cycle)
 - DAO Review

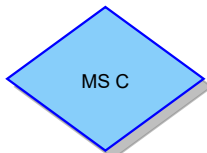

Acquisition Process Model

Program Reviews (Post MS C)

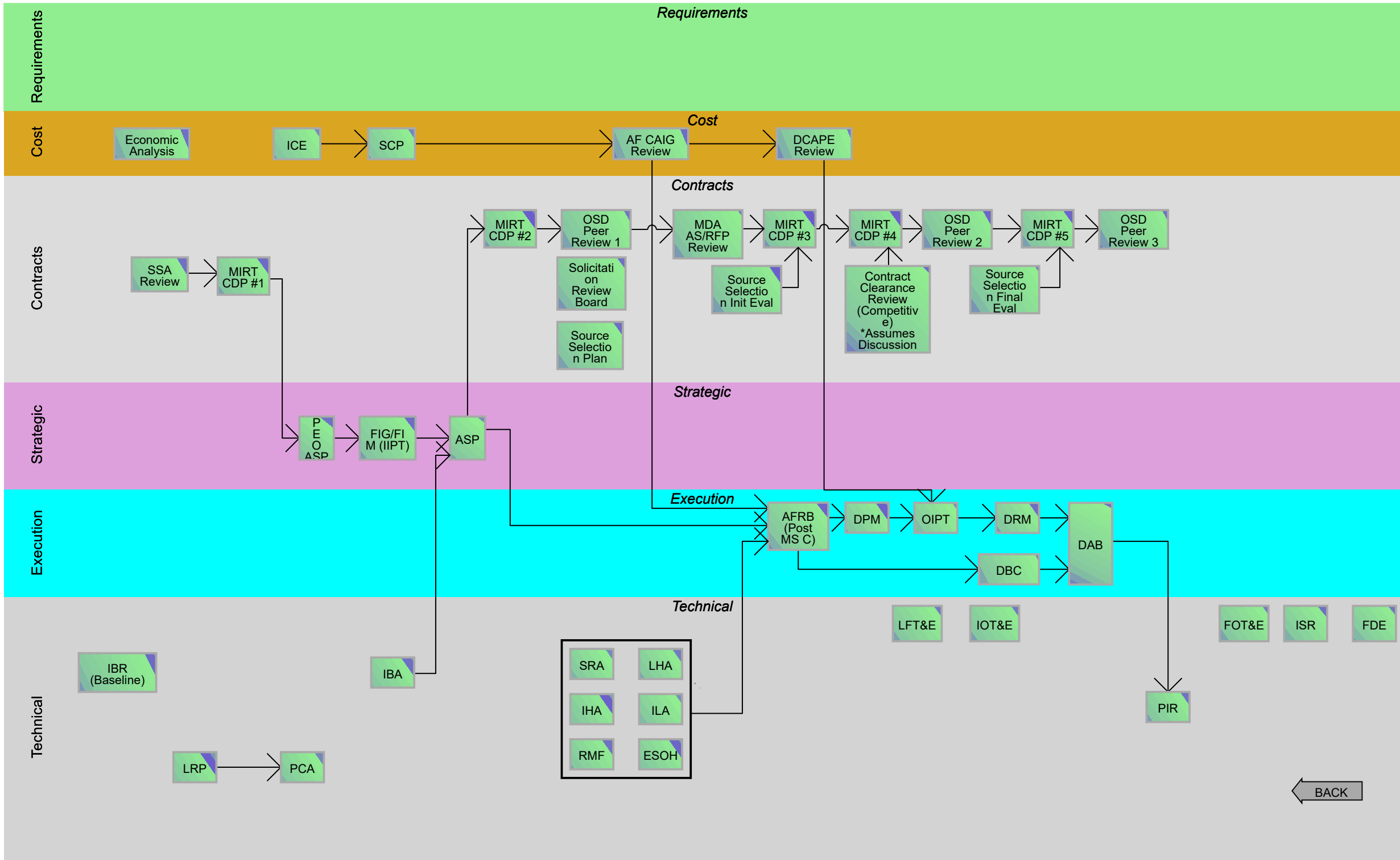
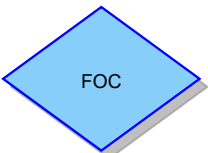
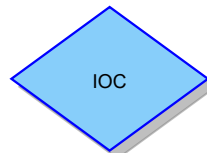
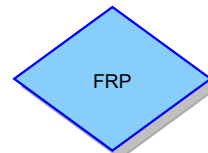

- Other Non-Milestone Related Reviews**
- Acq/Sust Review
 - SPR/IBR
 - SEAM
 - CSB
 - Staffer Day Brief
 - Audits/Inspections
 - PEO Portfolio Review
 - SAE Monthly Review
 - ILCM Executive Forum
 - DAES Reviews
 - Program Management Reviews
 - AFRB Post MS C (Out of Cycle)
 - DAO Review

← BACK

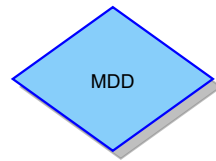

Acquisition Process Model

Program Reviews (Pre MDD to MS A)

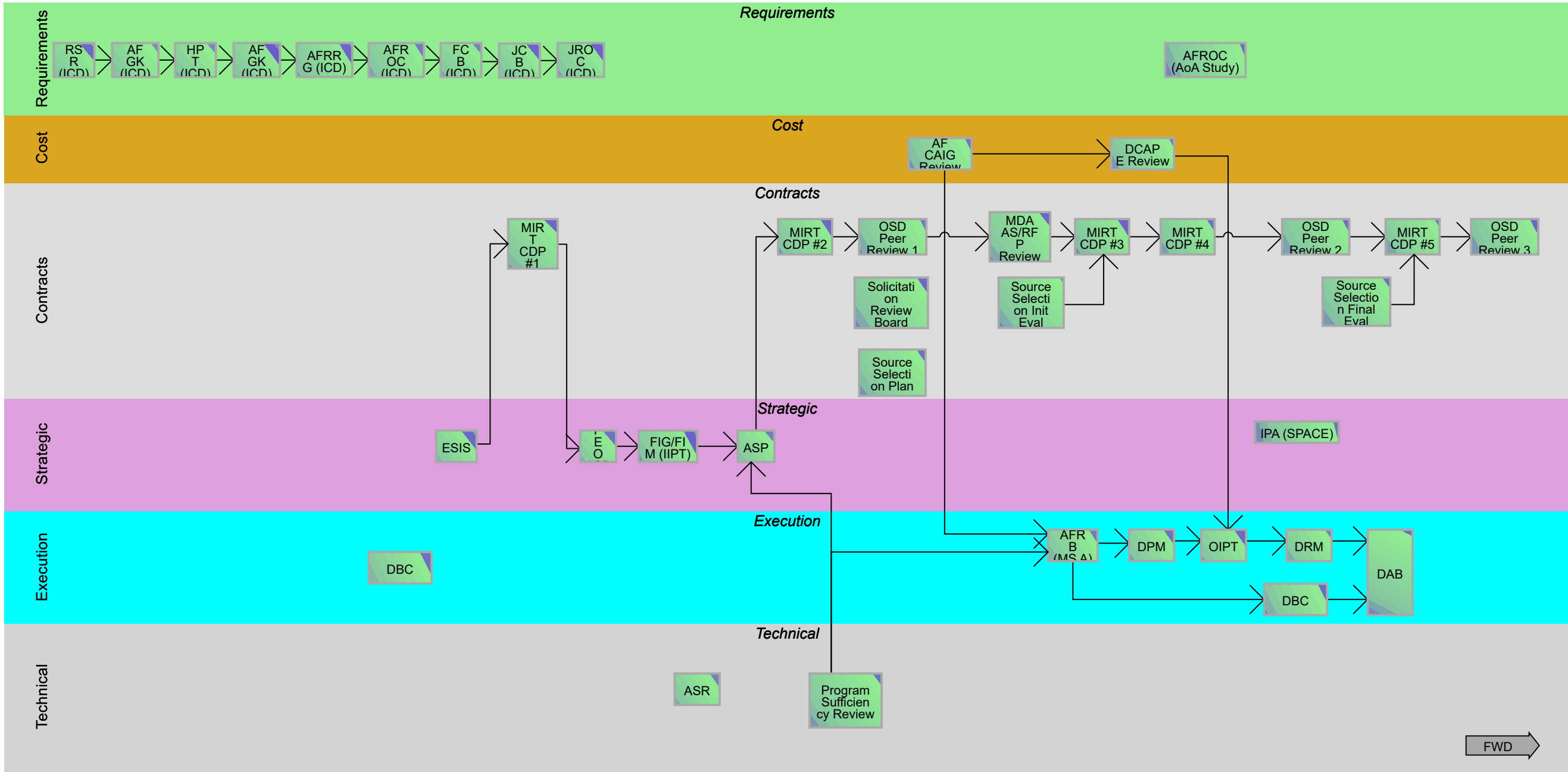
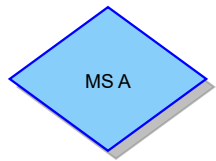

- Other Non-Milestone Related Reviews**
- Acq/Sust Review
 - SPR/IBR
 - CSB
 - Staffer Day Brief
 - Audits/Inspections
 - PEO Portfolio Review
 - SAE Monthly Review
 - Program Management Reviews
 - AFRB MSA (Out of Cycle)
 - DAO Review



Acquisition Process Model

SB. 1 Small Business Program Execution

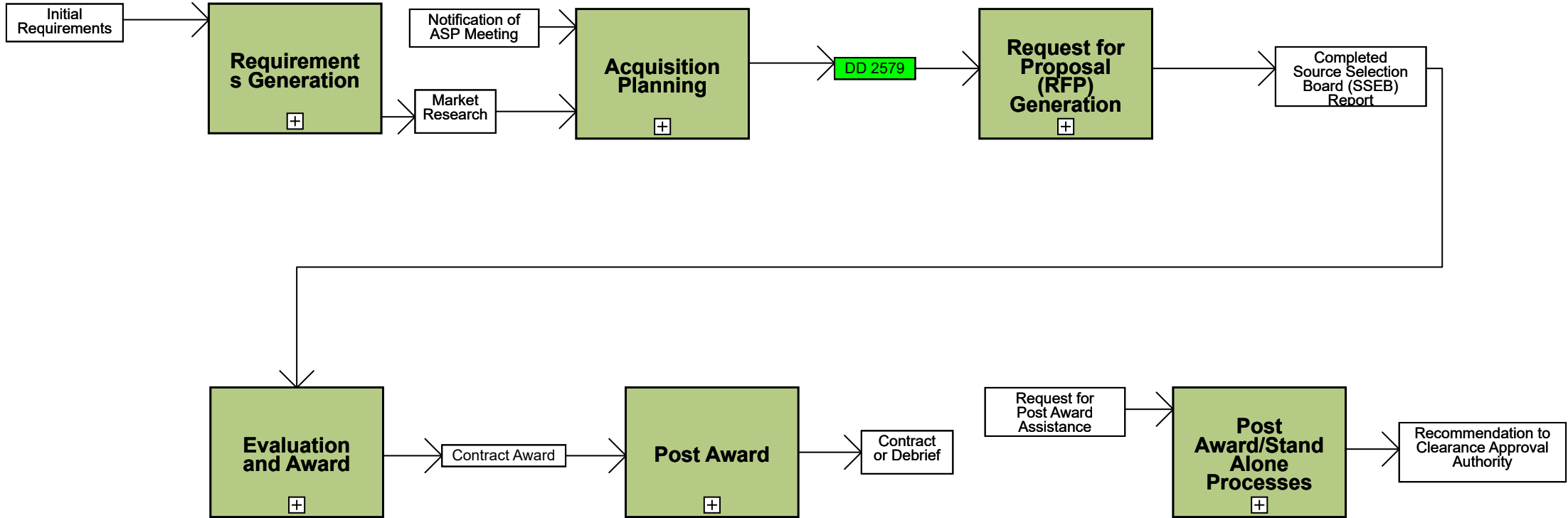



Acquisition Process Model

SB. 1.1 Requirements Generation

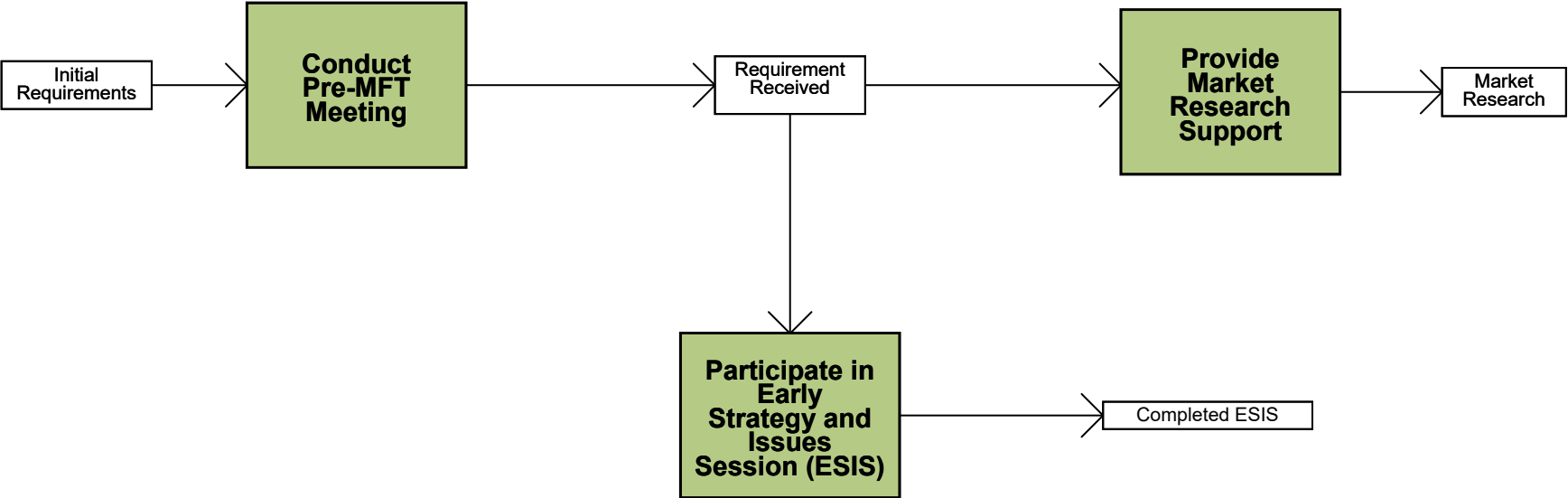

Note: For information regarding Conduct Market Research click the link below:
[1.3.2.5 Develop Acquisition Strategy](#)



Go Up 1 Level

Acquisition Process Model

SB. 1.2 Acquisition Planning

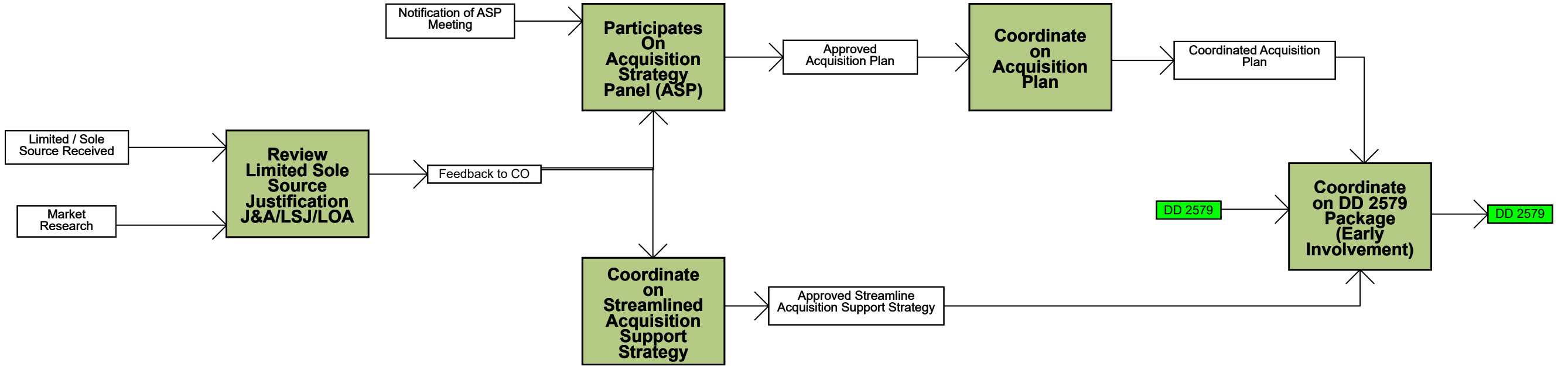

Note: For additional information regarding ASPs click the link below:
[1.1.3.3 Acquisition Strategy Panel \(ASP\)](#)
[1.1.3.3 Acquisition Strategy Panel \(ASP\)-Center](#)

← BACK

FWD →



Acquisition Process Model

SB. 1.3 RFP Generation

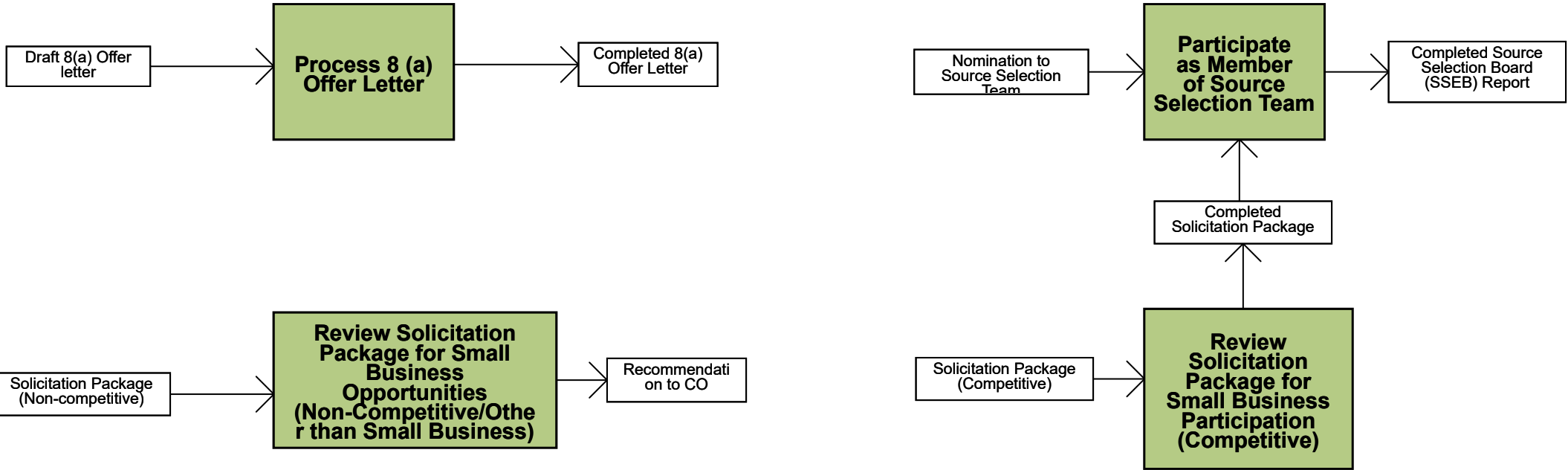

Note 1: For additional information regarding Solicitation Package click the link below:
[1.4.4.1 Conduct Pre Source Selection Activities](#)

Note 2: For additional information regarding Source Selection Team click the link below:
[1.4.4.1 Conduct Pre Source Selection Activities](#)





Acquisition Process Model

SB. 1.4 Evaluation and Award

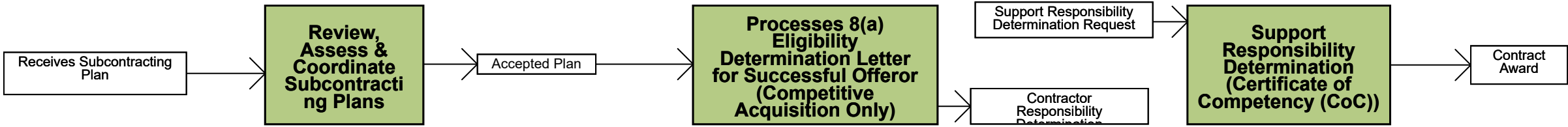

Note: For additional information regarding Subcontracting Plans click the link below:
[1.4.4.4.2 Conduct Fact Finding and Evaluation](#)



Go Up 1 Level

Acquisition Process Model

SB. 1.5 Post Award



← BACK

Go Up 1 Level

Acquisition Process Model

SB. 1.6 Post Award/Stand Alone Processes

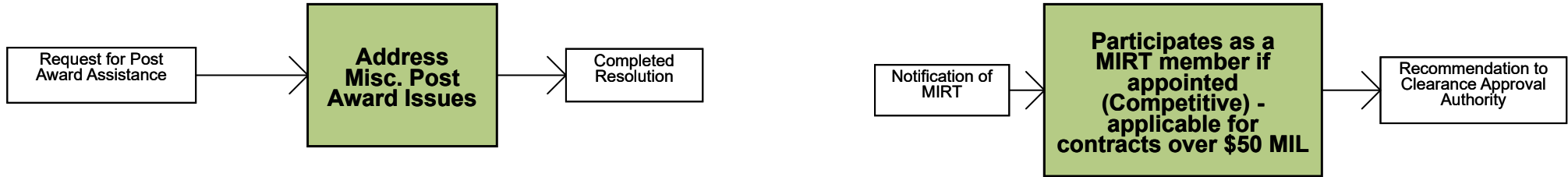

Note: For additional information regarding MIRTs click on the links below:

- 1.3.2.5.6 Conduct CDP 1 (Pre-ASP) MIRT
- 1.4.4.1.3 CDP 2 (RFP Sections L and M) MIRT
- 1.4.4.2.1 Conduct Initial Evaluation
- 1.4.4.2.7 Conduct CDP 5 (Pre-Source Selection Decision Brief) MIRT

Go Up 1 Level

Acquisition Process Model

SB. 2 Small Business Industry Outreach

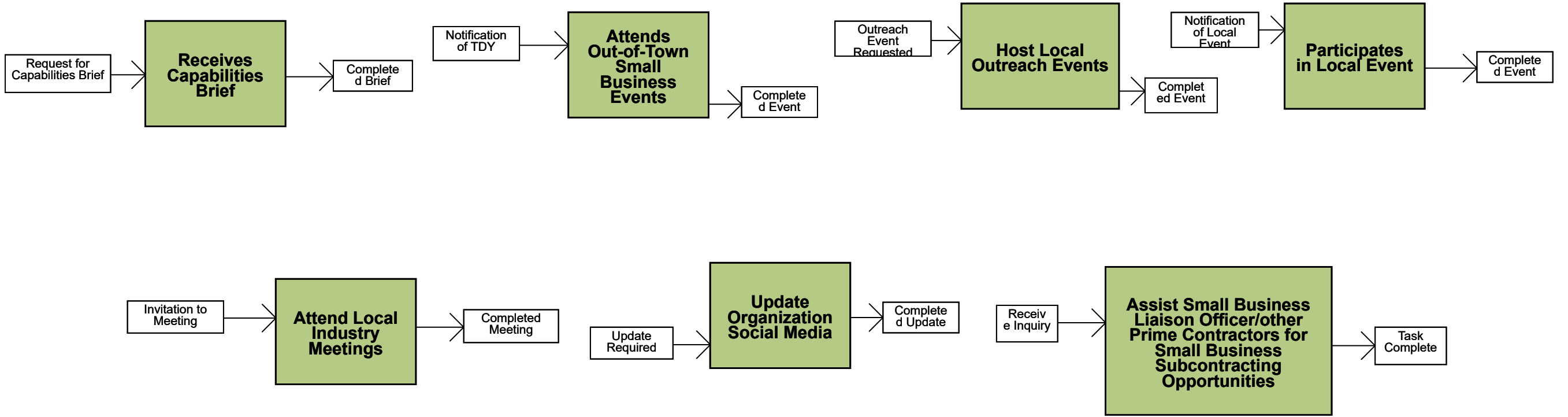

Go Up 1 Level

Acquisition Process Model

SB. 3 Small Business Training

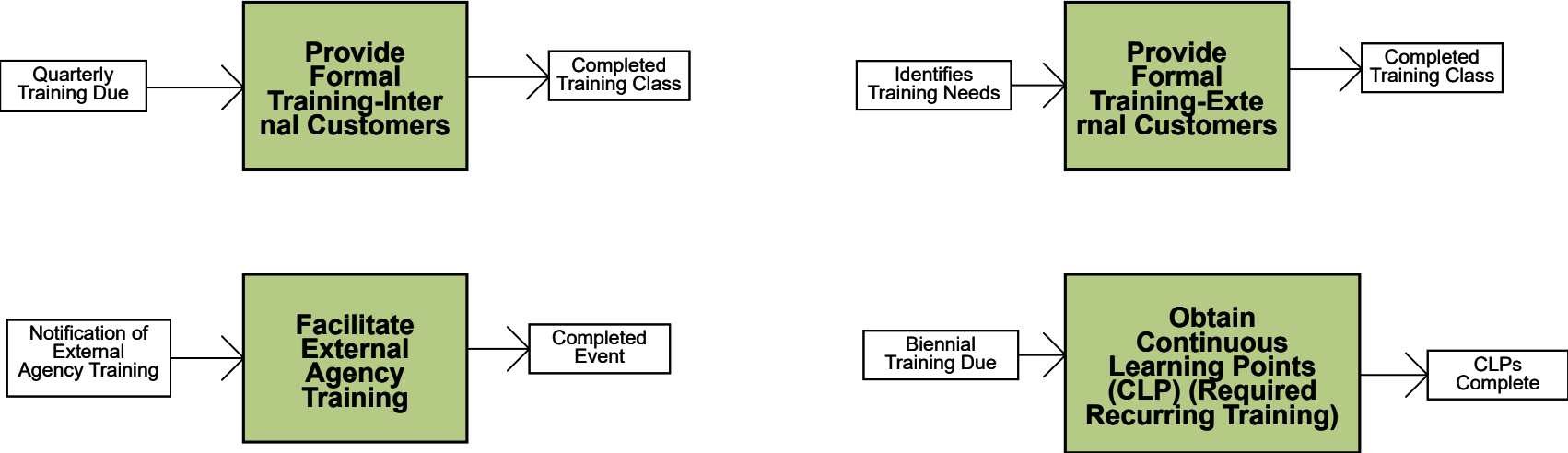

Go Up 1 Level

Acquisition Process Model

SB. 4 Small Business Program Management

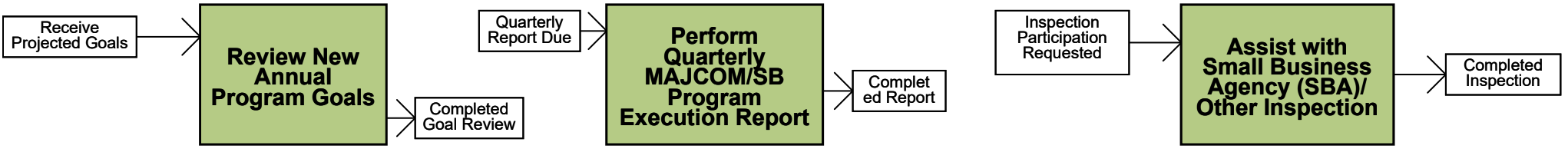
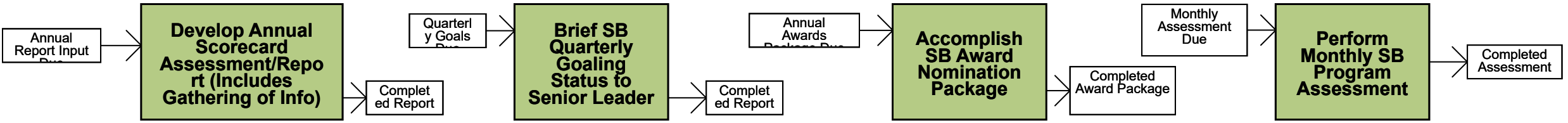

Go Up 1 Level

Acquisition Process Model

SB. 5 Small Business Policy

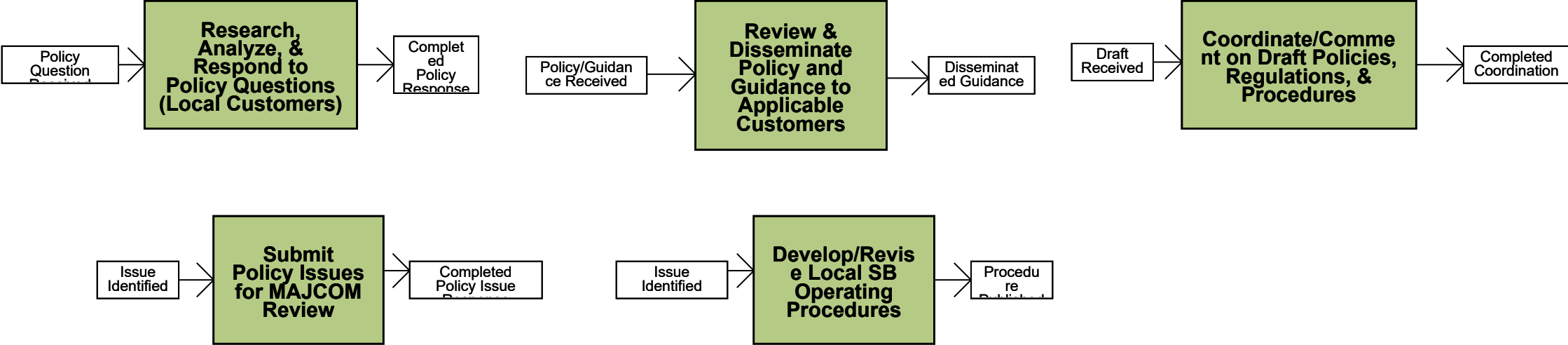

Go Up 1 Level

Acquisition Process Model

SB. 6 Small Business Communication

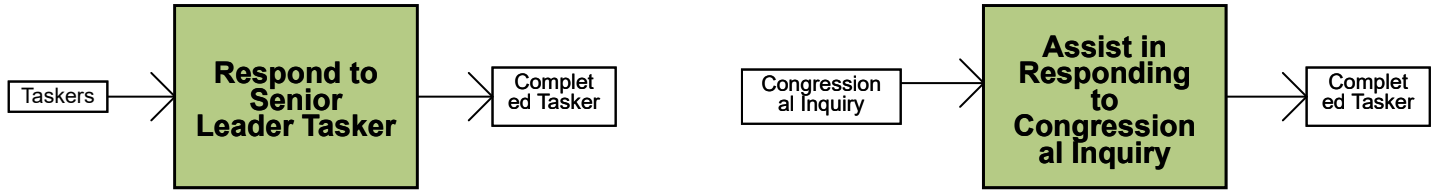

Note: For additional information regarding Communication click the link below:
[1.5.2 Manage Communication and Reports](#)

Go Up 1 Level

Acquisition Process Model

Small Business View

Small Business
Program Execution
+

Small Business
Industry Outreach
+

Small Business
Training
+

Small Business
Program Management
+

Small Business
Policy
+

Small Business
Communication
+